

Fast 1 kV metal-oxide-semiconductor field-effect transistor switch

C. J. Dedman, E. H. Roberts, S. T. Gibson, and B. R. Lewis

Citation: [Review of Scientific Instruments](#) **72**, 3718 (2001); doi: 10.1063/1.1389488

View online: <http://dx.doi.org/10.1063/1.1389488>

View Table of Contents: <http://scitation.aip.org/content/aip/journal/rsi/72/9?ver=pdfcov>

Published by the [AIP Publishing](#)

Articles you may be interested in

[Fast organic electronic circuits based on ambipolar pentacene field-effect transistors](#)

Appl. Phys. Lett. **79**, 4043 (2001); 10.1063/1.1426684

[Electric-field dependence of mobile proton-induced switching in protonated gate oxide field-effect transistors](#)

Appl. Phys. Lett. **77**, 1849 (2000); 10.1063/1.1311608

[AlGaIn/GaN metal-oxide-semiconductor heterostructure field-effect transistors on SiC substrates](#)

Appl. Phys. Lett. **77**, 1339 (2000); 10.1063/1.1290269

[A 6 kV–150 A, 8 ns rise time pulse generator for excitation of ferroelectric cathodes](#)

Rev. Sci. Instrum. **70**, 1857 (1999); 10.1063/1.1149680

[Fast 8 kV metal-oxide semiconductor field-effect transistor switch](#)

Rev. Sci. Instrum. **63**, 1840 (1992); 10.1063/1.1143294

The new SR865 *2 MHz Lock-In Amplifier ... \$7950*





Chart recording



FFT displays



Trend analysis

Features

- Intuitive front-panel operation
- Touchscreen data display
- Save data & screen shots to USB flash drive
- Embedded web server and iOS app
- Synch multiple SR865s via 10 MHz timebase I/O
- View results on a TV or monitor (HDMI output)

Specs

- 1 mHz to 2 MHz
- 2.5 nV/√Hz input noise
- 1 μs to 30 ks time constants
- 1.25 MHz data streaming rate
- Sine out with DC offset
- GPIB, RS-232, Ethernet & USB

SRS Stanford Research Systems
www.thinkSRS.com · Tel: (408)744-9040

NOTES

BRIEF contributions in any field of instrumentation or technique within the scope of the journal should be submitted for this section. Contributions should in general not exceed 500 words.

Fast 1 kV metal-oxide-semiconductor field-effect transistor switch

C. J. Dedman, E. H. Roberts,^{a)} S. T. Gibson, and B. R. Lewis

Research School of Physical Sciences and Engineering, The Australian National University, Canberra ACT 0200, Australia

(Received 3 May 2001; accepted for publication 9 June 2001)

A fast, high-voltage switch based on cheap and readily available components is described. This simple circuit can switch 1 kV to ground with a fall time of ~ 2.5 ns, and has proved a cost-effective means of driving electrostatic gating and referencing devices in pulsed ion-beam experiments.

© 2001 American Institute of Physics. [DOI: 10.1063/1.1389488]

Ion-beam experiments frequently require fast, high-voltage pulse generators to drive deflection plates, potential re-referencing switches^{1,2} and other electrostatic devices. We are building a photofragment spectrometer employing a combined beam gating, bunching, and potential re-referencing unit of our own design.³ The success of this unit depends on the ability to switch 1 kV to ground within a few nanoseconds.

Fast, high-voltage pulse generators with sufficient speed and voltage rating are available, such as the 1000 V HV1000 unit from Directed Energy Inc., with a specified rise time of <7.5 ns driving a 50Ω load. However, such general purpose commercial solutions are more expensive than our approach and use specialized switching metal-oxide-semiconductor field-effect transistors (MOSFETs) to obtain the rated rise times.

The pulser described in this note will drive deflection plates or similar high impedance electrostatic devices with a rise time of 2.5 ns, and costs just a few dollars to build. It will not drive 50Ω , but it is not necessary to do so in many applications, such as our own, where the switching transistor can be located close to a high impedance, low capacitance load such as a deflection plate.

Our application³ actually requires two high-voltage switches, turned on simultaneously, represented by Q1 and Q2 in the circuit of Fig. 1. Point A is switched to ground, B is switched to -100 V, and the chain of 100Ω resistors creates a uniform electric field within the gating unit. In this discussion of the basic switching circuit, the second MOSFET Q2, and its associated gate-drive transformer, will be neglected, and the drain of Q1 is assumed to be simply connected to the high-voltage through 150 k Ω . Q1 is a 1000 V rated MOSFET, Motorola type MTP1N100E. For higher voltage requirements, MOSFETs such as Hitachi type 2SK1317 are available up to 1.5 kV. For still higher voltages,

series-connected MOSFETs must be used,¹ usually resulting in considerably slower switching.

The key to obtaining such fast switching speed is to keep the gate-drive impedance extremely low, and use the highest possible gate-drive voltage, thus maximizing the available gate-drive current. The circuit shown in Fig. 1 is very straightforward, but the fast switching speed depends critically on the construction of the gate-drive pulse transformer. The data sheet⁴ for Q1 specifies a typical rise time of 12 ns with a gate-drive impedance of 9.1Ω , so, clearly, a drive impedance substantially lower than this is required. A step-down gate-drive transformer (4:1 in this case) is highly advantageous because the source impedance is transformed as the square of the turns ratio. The published on resistance for the IRF610 driver MOSFET (Q3) is 1.5Ω , which is seen as a negligible $1.5/16=0.094 \Omega$ by the gate of Q1.

The gate-drive inductance is much more troublesome, consisting of connecting lead inductance, device lead inductance, and leakage inductance of the gate-drive transformer. Stray lead inductance on the primary side is not a significant problem due to the 16:1 impedance transformation. Specialized methods of pulse transformer construction are required to obtain sufficiently low leakage inductance. The actual construction is shown in Fig. 2. The primary consists of two windings connected in parallel, each having 12 turns, wound on a FairRite No. 5977001401 toroidal ferrite core. The secondary consists of eight parallel windings, each consisting of three turns. Thus, the total numbers of turns on the primary and secondary are equal (24), and the transformer may be regarded as bifilar wound, in that the primary and secondary turns alternate. The secondary windings terminate on a small printed circuit board (PCB) mounted at right angles to the main PCB, and Q1 is soldered directly to this small PCB, with a lead length of ~ 2 mm. In our apparatus, the drain of Q1 is located a few millimeters from an electrical feedthrough into the vacuum chamber. The total effective inductance in the gate circuit was measured by replacing the

^{a)}Electronic mail: ehr121@rsphysse.anu.edu.au

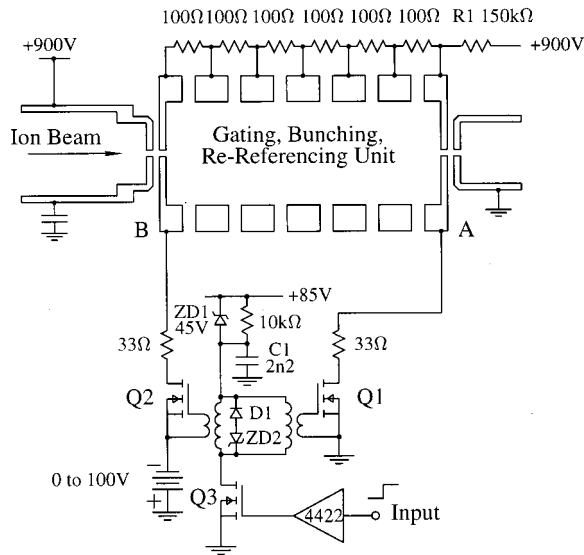

FIG. 1. Schematic diagram of the fast MOSFET switching circuit. This circuit includes the second MOSFET switch and bunching bias network required for driving the gating, bunching, and potential rereferencing unit described elsewhere (Ref. 3).

MTP1N100 MOSFET with a wire link of the same length, and measuring the reflected inductance across the primary with a Boonton model 71A inductance meter. Measured inductance across the primary was 240 nH, so the sum of leakage inductance and connecting lead inductance, referred to the secondary circuit, is $240/16=15$ nH. This value is ap-

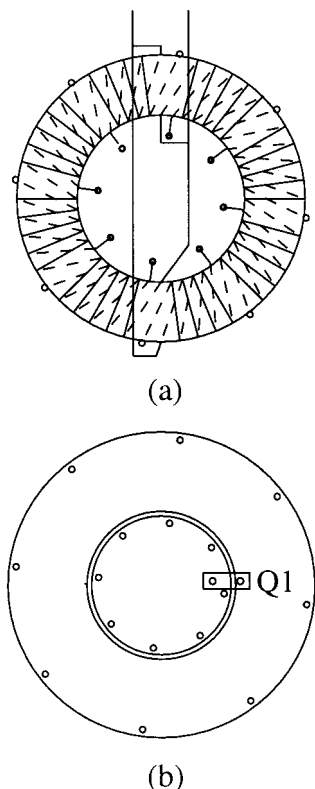

FIG. 2. Construction of (a) the pulse transformer, and (b) the associated printed circuit board, for the MOSFET drive circuit. This construction approach is required to minimize the MOSFET gate-drive inductance.

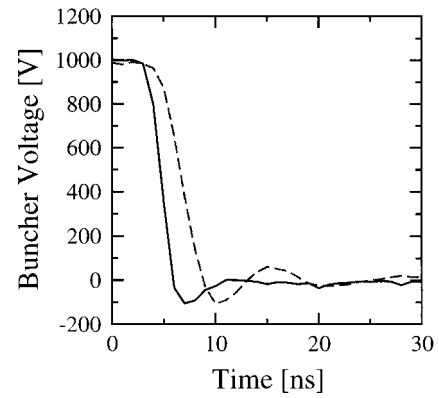

FIG. 3. Output waveform for the switching circuit, with no connected load (solid line), showing a measured fall time of 2.5 ns, and waveform when connected to the gating hardware (dashed line), showing a measured fall time of 3.2 ns. The slight ringing is of no consequence in our application, where the gate is effectively shut below 200 V.

proximate only, because the inductance meter was at the lower limit of its measuring range.

As with any pulse transformer, having fewer turns results in higher speed, at the expense of a shorter maximum pulse length before core saturation. The purpose of ZD1 and C1 is to extend maximum pulse length by providing a bilevel gate drive: initially 20 V to enhance turn-on speed, dropping to 10 V after 500 ns, as C1 discharges. We achieve a maximum pulse length of 8 μ s, compared with 4 μ s or so if the bilevel drive were not implemented. Diode ZD2 clamps the transformer back EMF when Q3 is switched off.

A precise calculation of fall time would be complicated, and probably worthless because the transformer leakage inductance is not known accurately. A very approximate estimate of fall time can be made as follows. MOSFET switching is controlled by the gate charge, and MTP1N100 data⁴ show that this device will be fully switched on with a total gate charge input of around 5 nC, at a gate-to-source voltage of about 5 V. Therefore the average gate voltage during switch-on is low (~ 2.5 V) compared with the 20 V gate drive, and we make the approximation that the entire gate-drive voltage is applied across the gate-drive inductance. Therefore,

$$di/dt = V/L \tag{1}$$

and

$$i = dq/dt, \tag{2}$$

where V is the gate-drive voltage, assumed to be much higher than the gate voltage during switch-on, i is the gate current, L is the total effective gate-drive inductance, and q is the gate charge. Combining Eqs. (1) and (2) with the boundary conditions that the gate charge and current are zero at $t=0$, gives an expression for the time T taken for a total charge Q to be injected into the MOSFET gate:

$$T = \sqrt{2LQ/V}. \tag{3}$$

For our circuit, $V=20$ V, $Q=5$ nC, and $L=15$ nH. Substituting these values into Eq. (3) gives a fall time of 2.7 ns. Note that Eq. (3) takes no account of the finite rise time of

the waveform on the pulse transformer primary, and the MTP1N100 gate-charge data are, strictly speaking, only correct for switching 400 V across a resistive load, at a current of 1 A. Nevertheless, Eq. (3) is useful for obtaining an estimate of fall time in this circuit.

A Tektronix TVS621 250 MHz, 1 G sample/s digitizer, with a PMK model PHV621 high-voltage probe, was used for all measurements. Figure 3 shows the output pulse with no connected load (solid line) except for 6 pF probe capacitance, giving a measured fall time (90%–10%) of 2.5 ns, in good agreement with the value calculated above. For real applications where Q1 can be located very close to the (low capacitance) load, a fall time of this order should be achievable. In our case, the electrostatic gating unit³ was connected to the pulser via 80 mm leads, and 33 Ω series resistors were found necessary to minimize ringing caused by the unmatched connection and the significant capacitance of the gating unit. Figure 3 also shows the slight ringing measured at the gating unit (dashed line), which is of no consequence in our application where the gate is effectively shut below 200 V.³ Fall time is degraded to 3.2 ns, which is adequate for our application, but better performance could be obtained by minimizing the 80 mm length of connecting lead. Our application requires only the falling edge to be fast, so the slow

rising edge of the pulse has a time constant dictated by R1 (150 k Ω) and the stray capacitance. If necessary a second MOSFET could be used for a fast trailing edge. Measurement of the trailing time constant implies a capacitance, including probe, of 15 pF with the gating unit connected, and 7 pF without. As the published probe capacitance of 6 pF is a significant proportion of the total, the actual switching performance without probe is probably better than measured. This high voltage pulser has proven reliable, cheap and simple to build, and faster than many expensive commercial solutions, for applications where 50 Ω drive capability is unnecessary.

This work is funded by a Major Equipment Grant from the Australian National University. One of the authors (E.H.R.) is the recipient of an Australian Postgraduate Award.

¹R. E. Continetti, D. R. Cyr, D. Osborn, D. Leahy, and D. M. Neumark, *J. Chem. Phys.* **99**, 2616 (1993).

²G. E. Yefchak, G. A. Schultz, J. Allison, C. G. Enke, and J. F. Holland, *J. Am. Soc. Mass Spectrom.* **1**, 440 (1990).

³C. J. Dedman, E. H. Roberts, S. T. Gibson, and B. R. Lewis, *Rev. Sci. Instrum.* **72**, 2915 (2001).

⁴Motorola Technical Data Sheet, MTP1N100E/D.