



Australian
National
University

THESES SIS/LIBRARY
R.G. MENZIES LIBRARY BUILDING NO:2
THE AUSTRALIAN NATIONAL UNIVERSITY
CANBERRA ACT 0200 AUSTRALIA

TELEPHONE: +61 2 6125 4631
FACSIMILE: +61 2 6125 4063
EMAIL: library.theses@anu.edu.au

USE OF THESES

This copy is supplied for purposes
of private study and research only.
Passages from the thesis may not be
copied or closely paraphrased without the
written consent of the author.

J.P. SINGH UBEROI

Social organization of the Tajiks of Andarab valley, Afghanistan

PRECIS of a thesis submitted for the degree of Ph.D. in the
Australian National University, Canberra

1964

The thesis is a description of the social organization of the Persian-speaking peasantry and part-pastoralists of a highland district in the central Hindu Kush of Afghanistan. Andarab district, with an estimated population of 33,000 souls, constitutes a geographical as well as governmental entity, and, as the people are orthodox Muslims, it is also a small segment of the cosmopolitan Islamic fraternity.

The thesis falls into two parts, which are separated by a statement of the methods of fieldwork (Chapter III) employed in the prevailing political and local circumstances.

The first part (Chapter II) attempts a comprehensive report of Andarab. After an account of the geographical, ecological and demographic background, it describes the division of the population into individual autocephalous households, either simple or polygynous, and grouped into village communities on the basis of patrilocal domicile. The factors of socio-economic stratification are specified. An examination of the boundaries of the four "electoral wards" into which Andarab is divided, suggests that a system of competitive oppositions is the main theme in political activity.

The second part of the thesis presents exploratory material on the local community, the Afghan state, and Islam.

Chapter IV suggests that, in the absence of corporate estates

and succession by descent, the dynamic of the individual's life-career in his local community derives from the cycle of domestic development and his position vis-a-vis his coparceners as well as other kin relations. The Koranic rules of marriage and inheritance are given, and followed by an examination of their characteristic patterns among clusters of close collateral agnates, which are the only factional groups within the local community. An illustrative case of a matrilateral cross-cousin marriage within one village, shows that competitive opposition comes to a head over questions of marriage bestowal and bridewealth.

Chapter V describes the system of local government; and the careers in Andarab of two successive deputy commissioners, with reference to their policies in dealing with the departmental personnel within the district secretariat, and also the circle of native intermediaries through whom the business of administration must be carried on.

Chapter VI deals briefly with the rites through which the local community is integrated in to cosmopolitan Islam. The main element in these rites of Muslimhood is the congregational one, and the seclusion of women rigidly excludes them from participation in it. It is suggested that the function of purdah is to define the particularist side of local citizenship, while the communal and universalist side is enjoined on the men by the periodic congregational rites.

J. P. SINGH UBEROI

SOCIAL ORGANIZATION OF THE TĀJIKS OF ANDARĀB VALLEY,
AFGHĀNISTĀN

Thesis

submitted for the degree of Doctor of Philosophy in
the Australian National University, Canberra

1964



This thesis is my own original work, based upon fieldwork carried out in Afghanistan in 1959-61, with the kind support of the Royal Anthropological Institute, London (supplemented by the Wenner-Gren Foundation for Anthropological Research, New York); and the Australian National University, Canberra.

J. P. Singh Uberoi

TABLE OF CONTENTS

I	Afghanistan	1
II	Andarab	9
	1. Physical geography	11
	2. Agriculture and pastoral ecology	17
	3. The population and demography	24
	4. Social organization	29
	5. The village community	37
	6. The community of Andarab district	45
	7. The grades of society	60
	8. Commercial life	70
III	The field situation	78
	1. Method of fieldwork	79
	2. Categories of social structure	86
IV	Family, kinship and community	90
	1. Introduction	90
	2. Inheritance and marriage rules	97
	3. The kinship terminology	116
	4. Agnatic clusters of households	124
	5. An illustrative case	137
V	The Afghan state	149
	1. The district secretariat	152
	2. Administration and politics	170
VI	Islam	181
	1. The rites of Muslimhood	182
	Bibliography of references cited	195

LIST OF MAPS

	facing p.
1. The central Hindu Kush	9
2. Andarab (physical)	13
3. Andarab (village headmanship & electoral wards)	39

LIST OF DIAGRAMS

facing p.

1.	Approximate distribution of the population by age and marital status	25
2.	Schematic socio-economic strata	62
3.	Andarabi social organization	86
4.	Marriage prohibitions	106
5.	The closest forms of contemporaneous marriages	110
6.	Marriages within one agnatic cluster	112
7.	Terms of kinship in common use	117
8.	Categories of affinal kin	120
9.	Agnatic cousinhood	122
10.	Household composition & development with one agnatic cluster	129
11.	Illustrative case of mother's brother's daughter marriage	138
12.	The district secretariat	152
13.	Effective circle of district administration and politics	170

LIST OF TABLES

	facing p.
1. Ownership of irrigated (<u>ābi</u>) land	66
2. First cousin marriage rates	95
3. Terms of kinship in common use	116

CHAPTER I

AFGHANISTAN

The population of the kingdom of Afghanistan is variously estimated at between six million and fifteen million, the current estimate of the Kabul government being the latter, higher figure. The true figure, which may be closer to nine or ten million, can only be determined when a full-scale population census can be undertaken. The geographical distribution of the population, and its sub-divisions in terms of ethnic and linguistic categories, and socio-economic strata, can only be assessed provisionally until that time. In broad and general terms, the dominant people of Afghanistan are the Pashto-speaking Afghans, settled as well as nomadic. The number of Pashto-speakers in the country may be between one-third and one-half of the total population. The original homeland and main strength of these people lies to the east and south. They are traditionally divided into various tribal groups, each with its own chiefs. The different tribes have similar customs, a common tribal code (Pashtunwali), and an inclusive consciousness. The two million people in the country who live by pastoral nomadism are Afghans mainly.

The second most important element in the population are the Persian-speakers (Farsiwans) or Tajiks. The native Persian-speakers in different parts of the country number perhaps one-quarter to one-third of the total population. They are everywhere settled cultivators, artisans, and traders,

etc., and have been so from the earliest times. They do not possess any tribal system, and have no over-all consciousness as Farsiwans or Tajiks. Their social organization is everywhere based upon their village, locality or region. It is surmised that "until the Afghan tribes began their northward movement from the Sulayman mountains around the tenth century A.D., and the Uzbeks established themselves in Afghan Turkistan around the sixteenth century, the Tajiks constituted the chief population of Afghanistan."¹

The other ethnic and linguistic groups to be found are the Uzbeks and Turkmen in the north (Afghan Turkistan), the Hazaras in the centre (Hazarajat), the Nuristanis (former Kafirs) in the north-east (Nuristan), and the Baluchis in the south-west (Afghan Baluchistan). There are some still smaller communities of diverse origin, among whom are the few Jews, Hindus, and Sikhs, of long domicile.

The exact boundaries of Afghanistan were not fixed until almost the close of the nineteenth century, when the direct control of the Kabul government was finally established over all parts of the country. Afghanistan achieved final independence in its external affairs in 1919, after the Third Anglo-Afghan War. Although inter-tribal turbulence, accompanied by dynastic struggles in the capital, continued almost into the present day, the general structure of the kingdom can be said to have persisted since its inception in 1747 A.D., when

1 D.N. Wilber, ed., Afghanistan (New Haven, Conn., 1956), p.46.

Ahmad Shah Durrāni was proclaimed shah of all the Afghans. The ruling power in the land today are the Muhammadzai section of the Durrani Afghans; and their supremacy over the other sections of the Durrani tribe is dated from the reign of Dost Muhammad (Amir of Afghanistan, 1834-63).

The royal Court as well as the government of Kabul at the present day is composed and constituted by the Muhammadzais. They control the civil administration of the country, and the command of the Army. They possess a good deal of land, and not only in their original homeland, but its extent is not sufficient to make them overwhelmingly rich. Every Muhammadzai is entitled to the honorific of Sardār (ruler). The foundations of the Muhammadzai power have up to the present rested upon: (1) their leadership of the Durrani tribe; (2) the support which they can elicit from the other Afghan tribes, who are powerful in their own right; (3) the acquiescence of the rest of the country, and general satisfaction with their rule. A further limitation on the Kabul government is imposed by the necessity to reckon with the religious establishment, who have hitherto constituted an independent power in the land, responsible directly to the people. The administration of Afghanistan is integrated and strongly centralized in intention, but prevailing circumstances, such as the tribal system and the general poverty of communications, allow the different regions to enjoy a measure of autonomy. The country is divided

administratively into seven major (governors') provinces, and nine minor (chief commissioners') provinces. The provinces are further subdivided into divisions, and finally into districts. The chief executive of a province is appointed by the Prime Minister. The other officers of the provincial administration, down to the district level, are career officials of the various ministries in Kabul, Ministry of the Interior, Ministry of Finance, Ministry of Justice, Department of Tribal Affairs, etc., etc. The provincial Army garrisons are under the control of the Minister of National Defence. The tribal chiefs in most areas (but not the chiefs of the nomadic tribes) are sought to be appointed by the central government, while the indigenous chiefs are given high posts in Kabul and elsewhere.

The organizations of defence (the Army), and the public order (gendarmerie, with a special municipal police in the cities), are manned largely by conscripts, who are recruited on the basis of two years' national service. The individual conscript is posted either to the Army, the border guards, the Afghan labour corps (employed in the construction of roads and public works); or to the gendarmerie and the municipal police. The officers of the gendarmerie and the police are permanent officers, belonging to the Security Branch of the Ministry of the Interior.

Islam is the universal religion of Afghanistan. The

majority of the people follow the orthodox Sunni faith, but a considerable minority (mainly the Hazaras) are Shiites. The faith and the code of life laid down by Islam, called shari'at, is based upon (1) the revealed book, the Koran, and (2) the hadis, or Traditions, authenticated reports of the example of Muhammad, which should be followed by the faithful on all matters. With the rapid spread of Islam, and the growth of a cosmopolitan community, there developed a corpus of interpretation, comprehensive and detailed, through (3) analogical reasoning or deduction from the Koran and the Traditions, and (4) concensus among the learned on disputed points. The orthodox Muslims (Sunnis) regard the authoritative interpretations to have been finally established by the four great Imams, doctors or legists, founders of the accepted schools of jurisprudence. These four schools, or "rites", do not differ on the essentials, but on minor points. The earliest and most widespread "rite" is that of the Hanafi school, and it is officially as well as popularly required to be adhered to by the King and the state in Afghanistan. It is interpreted to the people in their daily lives by their own mullahs, whose rulings they traditionally follow. The Islamic law, shari'at, is by its very nature a unitary system, comprehending the civil, the criminal, the religious, and the personal, spheres, under the one rubric. The principles of the Hanafi school of jurisprudence are applied in the Afghan law courts, mainly to the settlement of civil disputes. The

administration of the country, including the discharge of the magisterial function, is, on the other hand, guided and regulated by a growing body of statutory provisions (usūlnāmā), which are promulgated in Kabul under the authority of the King in council. The usūlnāmās are statutes, enacted on the model of parliamentary legislation. They are further supplemented by various directives and regulations issued by the different ministries. These usūlnāmās, etc. are designed to meet the modern needs not catered for by the shari'at; they show the influence of other, non-traditional sources.

Afghanistan possesses two written constitutions, one promulgated in 1923 (under King Amanullah), and the second in 1931 (under King Nadir Shah), but neither of them was successful in separating the powers of the executive, the judicial, and the legislative, components of the state; nor in realising modern representative institutions. An elective parliament assembles in Kabul (the National Assembly), and provincial councils are set up to advise the governors in the provinces, in accordance with the 1931 constitution. The National Assembly's functions and powers are very limited in practice; and there are no political parties. The general elections, which are held every three years, on the basis of adult (male) suffrage, are not wholly free or universal. On important decisions of policy the government has consulted directly with an ad hoc loya jirgah, a general assembly of notables called from all parts of the country. (The last loya jirgah meeting

was held in 1955 to discuss the Pashtunistan issue.) In the normal, everyday working of the administration, the voice of the people finds its effective expression piecemeal, through petitions, representations, and lobbying of officials. The accessibility of the officials to the people is, therefore, as important a consideration to the system, as their efficiency and firmness.

The economic foundations of Afghanistan are agriculture and pastoralism. Wheat and other grains, fruits, furs, hides and skins, wool, other livestock and dairy products, some cotton, and forestry, predominate. There is as yet no considerable manufacturing industry, though beginnings have been made by the government in textiles, sugar, soap, matches, and coal and electricity. The only important handicraft production is carpet-weaving. Internal as well as external trade and commerce are vitally important. The importance of the external trade can be judged from the fact that some 40% of the government's revenue is derived from customs duties.¹ It is said that the urban population numbers about one million, "making its living in trade, industry, handicraft, government, and services".² Owing perhaps to the broken and rugged terrain, and the strength of the tribal system in the pastoral areas, the countryside is comparatively free from landlordism and the latifundia system, individual small-owners generally predominating.

1 D.N. Wilber, ed., Afghanistan (New Haven, Conn., 1956), pp.168-9

2 Ibid., p.161.

The Persian spoken in Afghanistan, so-called "Afghan Persian", or Fārsi-i dari, "rural or mountain Persian", is the language of the capital, and serves as the lingua franca. It has remained the official and urban language in most parts, except in the Pashto heartland. Pashto is now given the government's backing, and is required to be taught, alongside the mother tongue, in schools throughout.

CHAPTER II

ANDARAB

The circumstances, character and particular customs of the Persian-speaking people differ widely from one part of the country to another, according to their locale and particular history. As yet no considerable research has been done which could enable us to classify the different groups or determine their characteristics with a fair degree of accuracy. Systematic knowledge of Afghanistan as a whole is at its beginnings only. It is known that the present Persian-speakers are the descendants of the original, sedentary Iranian inhabitants, but with an admixture over the ages of diverse intrusive settlers (Greek, Arab, Scythian, Turkic, Mongol, Uzbek, Afghan). It is reasonable to suppose, moreover, that the communities of the mountain districts are the heirs of the older culture and speech in its autochthonous form.

The present account relates only to the communities of the central Hindu Kush, i.e. the mountain districts straddling the central massif to the north of Kabul, situated to the north and south of an imaginary line drawn from the junction of Badakhshan with Nuristan in the east, to the district of Bamian in the west. This particular region is itself a part geographically of the longer chain of mountains which forms

a tremendous watershed and frontier, the "great divide" between central and southern Asia. The more accessible passes across the great barrier are contained in the central Hindu Kush. This is the part through which the great conquerors of the past, seeking a way, crossed. The main caravan route still in continuous use, crosses by the Khawak pass (11,600 ft). The main north road connecting Kabul with Afghan Turkistan goes by the Shibar pass (9,800 ft). The inhabitants of these mountain valleys, who are native Persian-speakers in the main, possess many salient characteristics in common, which are traceable to their similar habitat and modes of livelihood, affinities of historical development, more than ten centuries of adherence to the orthodox faith of Islam, and the common language. It can be said that the Persian-speakers of the central Hindu Kush constitute a distinctive group in the population of Afghanistan, though this should not be understood to imply the fact of their collective existence in the political sense. It is an ethnic and cultural homogeneity only.

The political unit is not larger than the single district, a territorial entity, circumscribed by the natural boundaries. The districts which lie to the north of the central dividing line are included nowadays in Qataghan province, while those situated to the south are administered within Parwan province. In past history too, the northern

districts often came under the suzerainty of whichever power arose on the Oxus plain, as against the southern districts, which tended to follow the political fortunes of the Kabul valley. At all periods, the intractable mountains in effect divided the people into separate, isolated communities, whose internal autonomy, moreover, was never entirely subjugated to outside control. Like highlanders everywhere, the people generally differ in character and temperament from their plains' cousins, who give them the reputation of rude frontiersmen and caterans.

I shall concentrate henceforward on the description of one particular district, the Andarab valley, estimated 33,000 population, as representing the social organization common to the region. I was able to reconnoitre in the other communities (Kohistan, Panjshir, Ghorband, Bamian, Kamard and Saighan, Doshi, Khinjan, Narin, Khost-o-Faring), during the course of my fieldwork, and can vouch that very similar social conditions exist there, with only minor differences. In the point of their ethnic composition, the purest communities are perhaps those of Kohistan, Panjshir, Andarab, Khost-o-Faring, and Khinjan.

1. Physical geography

Andarab is an elevated valley system on the northern face of the Hindu Kush. It lies in an elbow of two mountain ranges, the main ridge of the central Hindu Kush, and the Shashan range, which meet in the Khawak pass.

The straight length of the valley, along which flows the Andarab river, is from east to west a distance of some 65 miles, descending from the Khawak pass (11,600 ft high) to the village of Doshi (2,700 ft). The border of the administrative district of Andarab stops at a point 17 miles above Doshi, leaving the lower section of the river to the sub-district of Khinjan, which was subordinate to Andarab until the 1930s, but is now attached to Doshi.¹ The motorable road into Andarab comes from Doshi up-river for 35 miles as far as the village of Banu (4,900 ft), which is the administrative centre of Andarab, and six miles further to Deh Salah village (5,000 ft). At Banu and near Deh Salah are situated the two bazaars of the district, with 100 and 80 shops respectively, two caravanserais at Deh Salah and one in Banu. The two premier congregational mosques of Andarab are also in these two places, and so are the two major state primary schools, each with about 450 boys, one headmaster, and ten teachers. The grain market is held bi-weekly at Deh Salah, as this point is the geographical centre of Andarab, the tri-junction of the motor road with the old caravan routes to the north and south. From the plain of Deh Salah the northern route crosses the Murgh pass (7,500 ft), the boundary of Andarab, and leads to Khanabad and the other cities of Afghan Turkistan. The southern route to Kabul, via the much higher Khawak pass, is obstructed by the snows

¹ Khinjan as well as Khost-o-Faring were administered as sub-districts attached to Andarab.

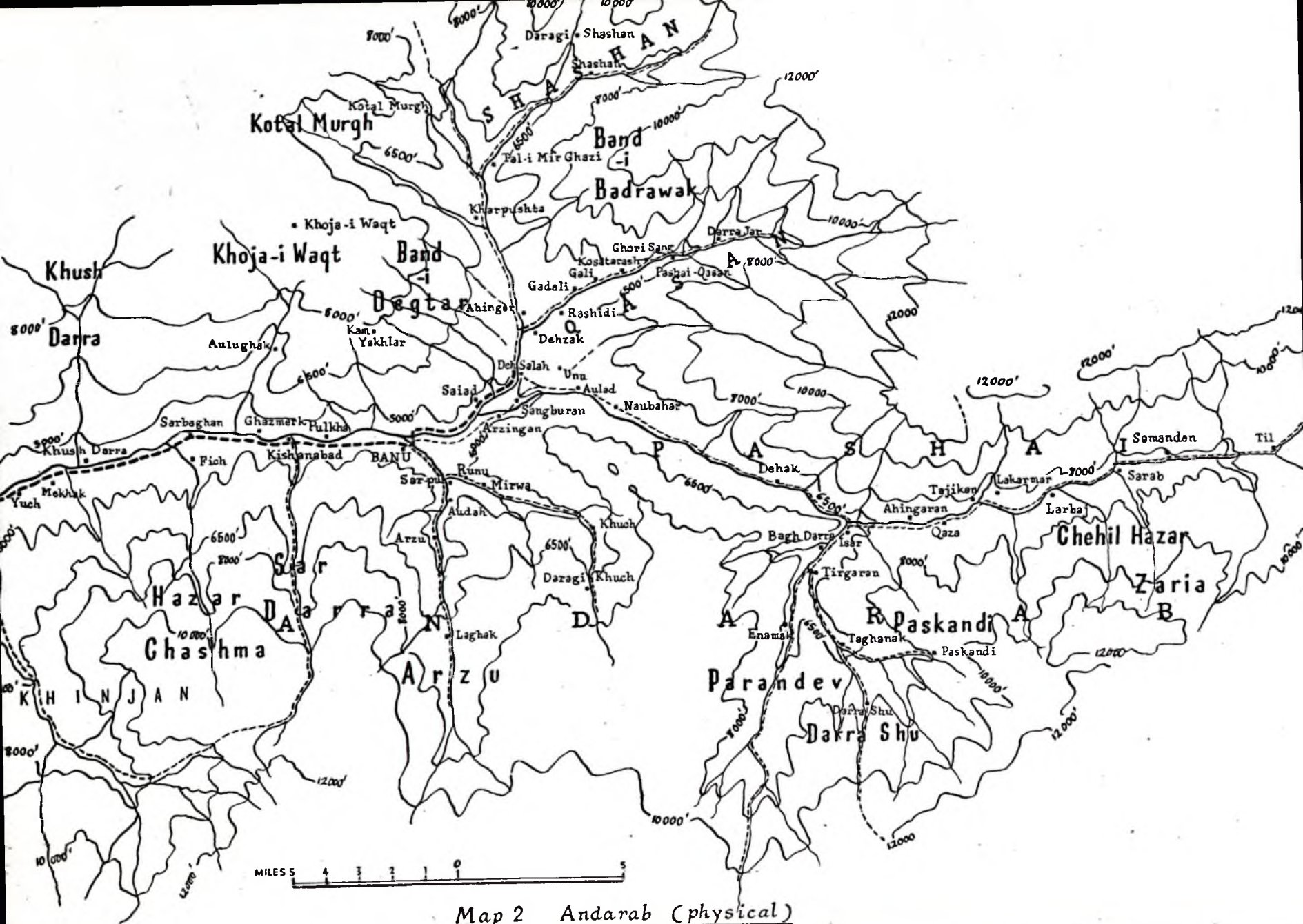

Map 2 Andarab (physical)

from November to mid-May usually.

The general setting and background of Andarab is that of wild, high and bare mountains, which are under deep snow for a period of the year. In the depth of winter there is no part of the district which is not severely cold, or free from snowfall. At the same time, the foreground, the valley floors from 4,000 ft. to 6,500 ft. are made up of alluvial soil, rich in many parts, and amply provided with water from the snowfed, swift-flowing rivers and streams. This is a wonderfully fertile oasis, perennially under tillage. In between the mountain peaks and the low-lying irrigated belt, the graded mountain folds, 6,500 ft to 9,000 ft, provide abundant upland pasture at the right time of the year, and also support dry-farming cultivation. The climate is continental and alpine, with four clearly marked seasons (spring, summer, autumn, winter), which determine the agricultural and pastoral cycles. The Afghan Persian new year commences on 22 March, and employs a solar calendar. The spring and autumn rains, though not adding up to many inches a year, are important in determining non-irrigated activities. The summer is very dry and hot. The weather in any one season varies appreciably from one place to another, depending upon the altitude and topographic relief.

The people divide their environment into the following five regions, according to their altitude and different use:

- (1) A narrow strip of irrigated arable (ābi), gently

terraced, and watered by channels (jūi), taken from the river or stream. This belt stretches with some interruptions from Kalat, the first village downstream at 4,000 ft, up to altitudes around 6,500 ft; its width and fertility vary from place to place. Most of it lies around the plain of Deh Salah and below; upper Pashai and Shashan possess very little. The total surface of these irrigated lands is reckoned officially at 11,000 acres (22,000 jarīb). In addition to these arable fields, there are also many walled orchards (bāgh), and small meadows (chaman), which are attached to the village settlements. The settlements are built of sun-dried brick or adobe and timber, either as a compact group (qishlāq, winter quarters), or as a separate walled compound (qal'ah, castle). A few stone huts are found, only in the remotest places. The habitations are dotted around the edges of cultivation, or sometimes in its midst, and draw their water supply from the irrigation channels. On the banks of the main river and its tributaries are sited occasional water-mills for milling flour (āsyā) and pounding rice (āb-jawāz). All that lies in this first belt of habitat is owned individually, as far as possible.

(2) An area almost equal to the irrigated acreage is cultivated as non-irrigated arable (lalmi), on the surrounding hilly land surface in different suitable parts, from 6,500 ft to 9,000 ft approximately. Its productivity varies enormously, depending upon its situation and the seasonal

precipitation. The surfaces are untterraced, steep and bare, with a rapid run-off of moisture. In a few places around 8,000 ft, where the relief is favourable and a reliable source of water is available, the ābi irrigation reappears. The different places with dry-farming cultivation are reckoned as an integral part of particular villages to which they are usually proximate, and disputes about them are rare. In general, the "lowland" villagers, who possess a sufficiency of irrigated arable, do not need to put extra labour into lalmi cultivation; the needy and the "hinterland" villagers, who are not so fortunately placed, must fall back on this rather laborious and uncertain mode of sustenance. There has not so far been a cadastral survey of the dry-farming surfaces, but they are registered officially (in the name of individual owners) to the total of 5,000 acres (10,000 jarīb). Their real extent must be more than this, perhaps as much as 10,000 acres.

(3) At similar altitudes, between 6,500 ft and 9,000 ft, and alternating with the dry-farming cultivation, is the region of upland pasturage (aylāq). The pasturage is distinguished as 'alaf, fine summer grasses fit for sheep, or as coarse jangal, fit only for goats. (There are many more sheep than goats.) The people who are considerable pastoralists set up regular summer camps (aylāq) in the grazing areas, when their families live in circular tents of reed-matting and felt, called chapari. These upland areas

are common pastures, traditionally allotted to particular groups with recognised permanent habitations in the district. Their total area is about 40,000 acres (75,000 jarīb). This assessment does not include the pastures of the Khawak region, which are officially the preserve of certain Afghan nomadic groups (kūchi), who migrate there annually from elsewhere.

(4) From about 8,000 ft to 10,000 ft is a forest and woodland region. The high mountain slopes (kōh) are sparsely covered with diminutive forests (jāngal) of cedar, yew, juniper fir, silphium and pistachio. Apart from going there for firewood, some people collect also medicinal herbs, asafoetida, wild garlic and rhubarb, cummin-seed, aniseed, mint, and gourds. This is characteristically the region of the hunt (shikār), mainly after ibex, mountain deer, and game birds. (In the past ten years a score or so families of Gujars, wandering from their original home in Asmar, eastern Nuristan, have found a precarious foothold in this region. The Gujars are Muslims, speaking Panjabi, and live exclusively by goat-keeping. They eke out the poorest living of all.)

(5) Above 10,000 ft are recognized limitrophe watershed regions (sarhad), which surround Andarab to the south, east, and north-east. These forbidding walls are impenetrable for the greater part of the year, though pierced near their tops by occasional passes (kōtal). The safest and most frequented of these passes is that of Khawak, which is also

the longest. The best route to Khost-o-Faring in the north-east goes by the Shashan valley.

2. Agriculture and pastoral ecology

The people derive their subsistence and income from, firstly, the cultivation of cereals, and secondly, the products of pastoralism. Most people combine the two pursuits in some proportion, and the pastoral revenue of the district exceeds the sums realised from the tax on cultivated land, but the people who are predominantly pastoralists number little over one quarter of the total population. I describe their pastoral ecology first, and the simpler agricultural ecology afterwards. They are distributed in the villages below Kishanabad, in the hinterland to the north, in Arzu and Khoja-i Waqt, in Pashai, in Shashan, and at Kotal Murgh, i.e. on the fringes of the irrigated arable in all the valleys which meet around the central plain of Deh Salah. They are distinguished as māldār, those who possess herds, as against dehqānkār, agriculturists. They practice an annual cycle of transhumance, and camp during the summer months in chaparis, grazing their flocks in particular different aylāqs, traditionally fixed.

The exact sequence of the māldārs' movements depends upon the particular group under consideration, especially as regards the distance travelled in search of spring pastures, and the relative dispositions of flocks versus people in the autumn. For instance, the movements of the

people of the lowest villages (Kalat, Yuch, Mekhak, Khush Darra, Sarbaghan and Ghazmerk), who are the smallest pastoral group, have a comparatively short range. Their flocks do not go further than the Khush Darra mouth in the spring. A while after the lambing season (April, May), people and flocks cross over to the south side, and camp up in Sar Darra and Hazar Chashma aylāqs for the summer (June, July, August, September). The ewes are out of milk by the end of August, when the families descend to their qishlāqs. The shepherds remain behind until later, taking the flocks in October to the northern side. During the winter the flocks shelter in north Khush Darra, where the weather is less severe. The most extensive migrations are those of the Pashai people, who are also the greatest pastoralists. In their case, there is an additional complexity, that many of them are not only māldār, but also gharībkār, i.e. engaged in migratory agricultural labour. Māldār as well as gharībkār are camped in chapolis during the summer, in the aylāqs from Parandev to Chehil Hazar. In September they divide up—even one household may split into two, the māldār to descend to their qishlāq winter quarters, the gharībkār to go north out of Andarab, to sell their labour in the Khanabad plains. Their separate existence lasts through the autumn and winter. After the winter has passed, some time late in March, the māldārs also make their way beyond Andarab to the northern foothills, the spring grazing

lands around Baghlan. They meet there the gharībkār families, who are on their return, and together they come back to summer again in their southern Andarab aylāqs.

The gharībkāri cycle is an innovation of the last twenty years; it has helped some of the inhabitants of Pashai to shake off the poverty enforced by their infertile land. Altogether over one third or 40 per cent of Pashai people are engaged in the migrant cycle of māldāri and gharībkāri.

The folk of Arzu follow a transhumant cycle almost as extensive as that of Pashai. They spend summer in their own Arzu aylāq and in Sar Darra (July, August, September), and spend their autumn (October, November, December) in their Arzu qishlāq, but descend later to Larkhao, a foothill halting place on the north-western edge of Andarab (January, February, March). With the new year they move further towards Pul-i Khumri for the spring (March, April to May, June); and then return to Arzu and Sar Darra aylāqs by way of Khush Darra.

Finally, the considerable pastoralists of Kotal Murgh, Shashan, and upper Qasan, do not make extensive migrations, but confine themselves to moves during the warmer months to their own upland aylāqs, which are sufficient to them.

In all instances, the pastoralists keep one eye on the cultivation of dry-farming lalmi, which they plough and harvest at the beginning and end of the summer months.

They do not usually want for their subsistence in cereals, even when they possess little or no ābi. As stated above, there is plenty of lalmi, but not all of it is equally good. Any extensive new cultivation can encroach on someone else's rightful pasturage, and the government also are anxious to conserve undiminished the pastures of the country. A long and fractious dispute recently ensued when some former grazing land was put under the plough in Band-i Degtar.

The main agricultural crops of Andarab are: wheat, barley, maize and millet; rice, coarse-grained and without transplantation of paddy; sesame, oilseed and poppy; tobacco; melon and water melon; vegetables (potatoes, sugar-beet, onions, carrots, radishes, tomatoes, cucumbers); beans and horse beans; and fodder crops, like lucerne, clover and rapeseed. The more desirable kinds of crop, e.g. rice, melon and superior wheat and barley, grow only on the lower valley floors, while the upper parts are limited to the hardier and poorer varieties. There are many species of wheat and, along with barley, this is the main dry-farming crop. Rice will grow at altitudes up to 6,000 ft, and so will melons. A great variety of trees, small and large, are grown for their fruit, wood, and shade, as well as for screening dwelling-houses. Such are the ash, walnut, hazel, plane, poplar and willow; the mulberry, which is used as a cereal plant; the grape, almond, apple, pear, apricot, cherry, plum, and quince. Again, the most delicate fruits are confined to a few places (Kishanabad is renowned for the flesh and stone fruits),

while the hardy mulberry is ubiquitous. The mulberry fruit, dried and eaten with walnuts, or made into syrup or even bread, and eaten with melted butter, will see even the poorest pastoralist through the severest winter.

Andarab is a country of one cereal crop per annum only, sown in the winter, spring or summer. The 11,000 ābi irrigated acres are planted every year, one year of rice in a particular plot being alternated with two years of wheat or barley. The small areas of ābi in cold and high places do not grow rice, and are assimilated to the lalmi inasmuch as every field must be allowed to lie fallow every alternate year. Around Deh Salah the soil is turned in between the last snowfalls, and the wheat fields planted by the end of March. Rice, maize and melon are planted in May, until when the animals are turned out in these fields. The harvesting begins in July and August; there is time to sow and reap the fodder crops in most fields until the agricultural year draws to a close in October. The hay stored in autumn must suffice the domestic animals through the winter, to ensure that the beasts of the plough at least are strong enough for their work early next spring. The fields are fertilized by compost, which is needed especially for rice, maize and melon. The common tools of cultivation are the wooden plough tipped with wrought iron, the heavy wooden leveller, the spade, scythe and winnowing fork.

The fields are measured in terms of the weight of seed grain which each will take, the unit being the sēr (one sēr

= 16 lbs), or the khirwār, equal to 80 sēr. The official register, however, gives holdings in terms of the jarīb, a surface measure, reckoned as the equivalent of 4 or 5 sēr (one jarīb = 0.5 acre). I was told that no field is less than half a jarīb (0.25 acre), and most are one jarīb (0.5 acre), in size.

At Tal-i Mir Ghazi, at the limit of rice cultivation, one sēr of rice will yield a return of six or seven sēr only, while the best rice land in Pulkha and Kishanabad will return 30 or 40 sēr. The productivity of irrigated wheat fields also differs from one part to another, but to a less marked degree. The main river is perennially dependable for irrigation, but its Shashan and Qasan tributaries can run low, when the jūi channels of different settlements must be opened only by agreed rotation.

The people habitually contrast the "lowland" villages—Banu, Kishanabad, Pulkha, Saiad, Arzingan, Sangburan, Deh Salah and Dehzak, on the one hand, against the remaining "hinterland", "fringe" or "upland" villages, especially upper Pashai and Shashan, on the other. The former, possessing the rice-bearing ābi, are popularly associated with a stable money income and satiated stomachs, education, refinement (or sneaking intrigue with the administration, according to taste), commerce, and generally lucrative occupations. The folk of the stony and wild country survive barely on maize, horse beans and mulberry, with scant cash

income (except if ever their dry-farming does well, or their flocks can multiply). They go in ignorance and indebtedness, engaged in unremitting labour, and confined to a narrow existence. There is certainly a deal of truth in this geographical contrast, provided that it is not overdrawn: the "lowland" fields also require laborious cultivation; the "infertile" country possesses all the pastures and natural woodland, as well as more dry-farming than appears at first sight; and most villagers of both contrasted regions in fact practise a mixed economy to some degree.

The domestic animals of Andarab are numbered, in round figures, as follows: 100,000 sheep, mostly of the fat-tailed varieties, 15,000 cattle, 4,000 horses, 4,000 donkeys, a few thousand goats and perhaps a dozen camels. This is the taxable livestock. In addition, there is domestic poultry, chickens, geese, a few turkeys. Sheep and house dogs and cats, sparrow hawks and fighting birds, are commonly kept. The sheep of Andarab are not of the karakul variety; their wool is coarse and unsuited for export use. They are milked, and kept for their meat, fat and skins, as well as wool. The cattle are kept for providing draft oxen and cows' milk, rather than for their beef, which is often poor in quality. All milk is churned, rather than drunk fresh, and sales of rōghan, clarified butter, provide an important income. Fresh butter and qurūt cheese are seldom sold, yoghurt and buttermilk never. The motor lorry traffic (reaching up to the Deh Salah bazaar) has practically

displaced the camel for heavy transport, but the horse is irreplaceable in this terrain and climate. It is the main means of travel, and transports also people's domestic effects during their seasonal migrations. Fine horses are sought after and cared for; the people love the buzkashi (the goat contest), a game of competitive horsemanship played in the late winter, in which hundreds participate. The lowly donkey, the "peasant's friend", is the main beast of burden to the agriculturist.

3. The population and demography

The people of Andarab (sing. Andarabi, plural Andarabiha) reckon their numbers either as so many domestic households (khānā), or as so many souls (nafūs), by which they refer to the male souls only. In my estimation they number, in round figures, a total of 33,000 souls, male and female, or approximately 4,500 households. In 1961 the district officials quoted the population as 14,296 male souls, or 4,800 households. These figures were based upon the enumeration of village headmen, and the official registers kept for the purposes of taxation. The figure for the male souls was alleged to coincide with the number of identity cards (tazkira), which were issued, supposedly to all males, in Andarab in 1956. The annual conscriptive call-up and other local administrative dealings are based upon this total, though it was acknowledged to be an underestimate of the true figure. The figure for the households, on the other hand, is the total number of male householders

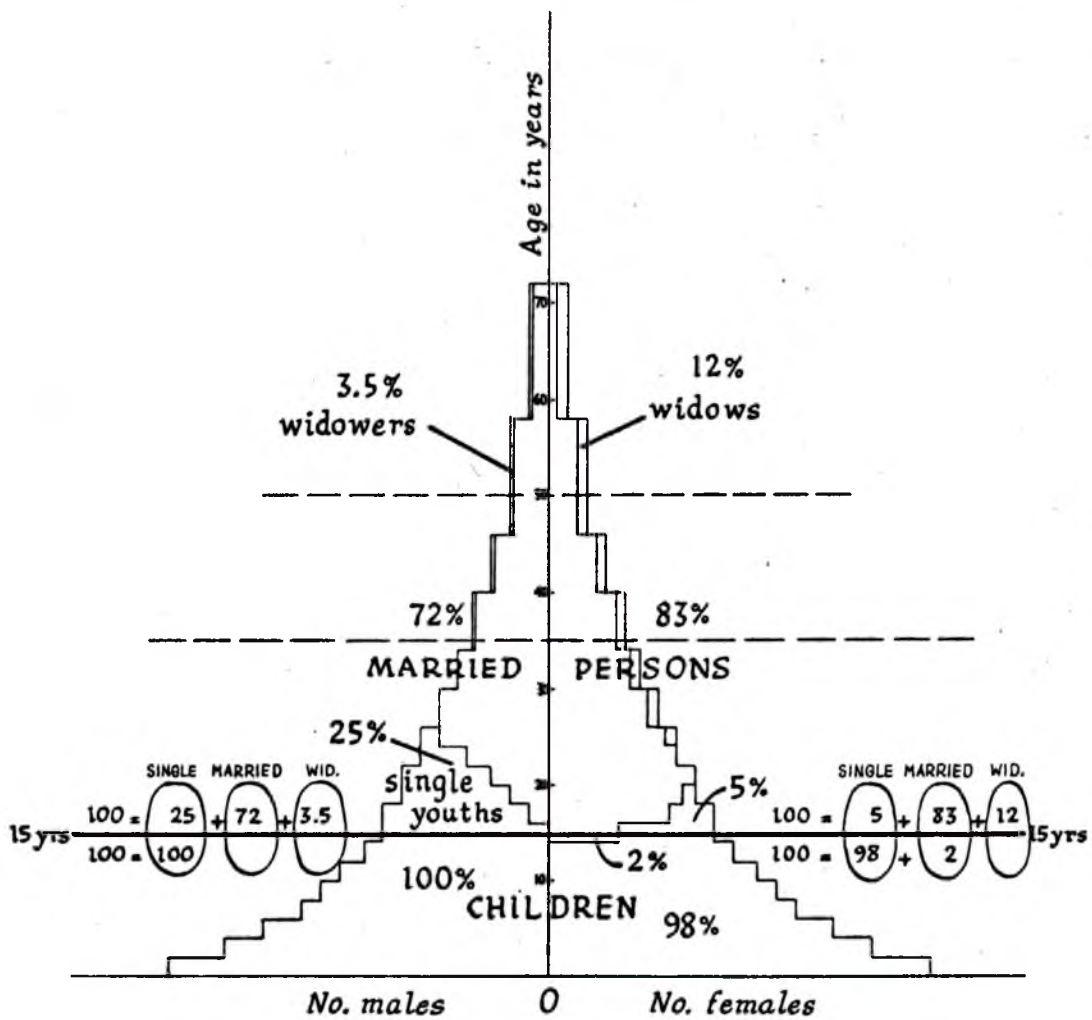

Fig. 1 Approximate distribution of the population
by age and marital status

from whom the taxes on livestock are collected during the annual circuit of the district for the purpose, by the Deputy Commissioner and other functionaries.¹ It was probably slightly overestimated.

About forty years ago, in 1922, the population of Andarab was given as 4,137 households, and an estimated 15,000 male souls.² (Until recent times in Afghanistan, it was the general custom to reckon the population in terms of households, and not individuals.) The population of the district appears to have remained almost constant over a long period; and if there was some increase from 1922 to 1961, as people maintain, it did not exceed 10 per cent.

I do not here enter upon the various points of evidence, but offer tentatively the following remarks concerning the demographic structure of the population. If one were to prepare an age pyramid, such as the one indicated in Figure 1, it would be shaped so that a line drawn horizontally at the

- 1 The district register of land does not reflect the number of households so well, since the coheirs of one owner generally postpone re-registration until their own families develop in severalty; and because parcels of land often change hands unnoticed in the register, by a customary sale between the parties to avoid incurring the additional expense of official registration.
- 2 Burhanuddin Kushkaki, Rahnumā-i Qataghan va Badakhshān (Kabul, 1925), p.45. This gazetteer of the two provinces (in Persian) was translated into Russian (ed. A.A. Semenov, Tashkent, 1926).

age level of fifteen years would bisect the population into two equal parts, showing as many persons above it, as young people below it. The birth rate is high, and so is the death rate, which falls most heavily upon infants. A boy at fifteen years is not quite adult, but many are already betrothed at this age. In the male half of society, above the age of fifteen, perhaps one quarter or 25% are still single youths, while the remaining three quarters are married men (72%) or widowers (3%) of different ages. Widowers marry again usually, and bachelorhood is reckoned as un-Islamic. The married men and widowers are distributed half of them or 50% below 35 years, 30% between 35 years and 50 years, and the remaining 20% aged over 50 years. The marital standing of the female population is very different. A cross-section of it taken at the age of fifteen would show a proportion to be newly married at that age, and the remainder to become married not long after. Wives are usually younger than husbands at marriage, although the opposite may be the case when a widow remarries. Above the age of fifteen, a very small part of the female population is made up of single girls in their late teens (5%), while the great bulk consists of married women (83%), and widows (12%). Widows are often remarried at almost any age; and spinsterhood is unknown. As an approximate assessment it can be said that of the total population of married or widowed females the majority (60%) are aged between fifteen and 35 years, with a few per cent aged even under fifteen (2%), perhaps 23% aged from 35

years to 50 years, and 15% over 50 years.

From a genealogical enumeration of Saiad village (see p. 32 below), it appeared that in a characteristic population containing say 100 married men there are five widowers of varying ages, some 119 married women, one divorcée, and 17 widows of all ages. About 15% of the married men are married to more than one wife at a time (12.5% to two wives, 2.% to three wives, about 1% to four wives). These polygynists are the well-to-do, in the upper half of society, and aged over 30 years. The few widowers occur generally among the poor. The widows occur much more frequently, and at all levels of society. Figure 1 is based on this kind of data. In the absence of any evidence to the contrary, it merely assumes the male and female proportions to correspond equally at every age. It certainly needs correction on this and other points of detail. It is more reliable in its general indication of the demographic structure that, in the total of 33,000 all souls, there are some 6,200 married or widower males and 8,000 married, widowed, or divorcée females; and that of the married men and widowers altogether 4,000 are aged over 30 years.

The people of Andarab (and Afghanistan generally) are more concerned with the distinctions of religion, speech, occupation, character, and the division between rulers and ruled, than with distinctions of ethnic origin. The people distinguish themselves from the Pashto-speaking Afghans as

"Farsiwan" or Persian-speakers, and refer to themselves as "Tajik" only rarely, when it is necessary to distinguish themselves from the Mongoloid Hazaras or Uzbeks, etc. who are also Persian speaking. The group life of the district is based upon local patriotism, above all else. One fifth or one quarter of Andarabis are of distinctly Hazara origin, but they are good Sunni Muslims, unlike the parent body of Hazaras in central Afghanistan, and therefore long inter-married with the presumed autochtones. There are a few immigrant Afghan families, including a small handful of Muhammadzai Sardars, settled as considerable landowners in Khush Darra, Banu, Arzingan and Saiad, who are reckoned with the natives according to their degree of intermarriage and length of residence. They are all Persian-speaking, and know practically no Pashto.

The Hazaras still tend to follow a distinct existence to the extent that they form the main pastoral groups, māldār. They are reckoned into four groups, totalling 1150 households or one-quarter of the population, distributed as follows:

- (i) Dālā, 500 households, in Naubahar and Paskandi;
- (ii) Qurghuli, 200 households, in Kotal Murgh and Shashan;
- (iii) Qūzi, 300 households, in Arzu, Laghak and Larkhao; and
- (iv) Abaga, 150 households, in Kalat, Yuch, Mekhak, Khush Darra, Sarbaghan and Ghazmerk. The Dalas of Naubahar and Paskandi, and the Quzis of Arzu, are the greatest māldārs, with their semi-nomadic migrations as explained in the

previous section. The Hazaras of Andarab¹ may once have been united in their headmanship in the past, but over the last two generations at least their different groups are attached rather to the different "lowland" villages, with respect to their region of habitation. The Naubahar and Paskandi Dalas provide the leadership of the Pashai sub-district usually.

4. Social organization

The fundamental groups and basic units of society are the 4,500 autocephalous households (khānā), among whom the 33,000 souls are assigned. The individual homestead (also khānā), especially its inner compound and dwelling-house (havēli), without its possible farm outbuildings, is ideally and in construction like a little castle. It is the repository of honour, a sacrosanct refuge into which none may force entry. The head of the household (kalān-i khānā), or paterfamilias (khānādār), is regarded as sovereign within the jealously-guarded domestic realm, and as virtually independent in relation to the outside world. It is universally preferred to reside patrilocally, and conjugal residence is viri-patrilocal. As long as the father is alive, he and his sons,

1 I follow local opinion in terming them Hazaras, but I am not competent to assess the undoubted Turkic elements in their speech sufficiently to conclude independently whether they are "true" Hazaras or belong to some other Turkic group. Similarly, I cannot speculate as to the original affiliation of the group described as Sākā (an ethnic term) who reside in Ahingar, near Deh Salah, nor say why Pashai, originally the name of an ethnic and linguistic group, should be applied to uppermost Andarab.

whether by one or more mothers, constitute a single household ipso facto. After the father's death, and following the inevitable partition of the estate according to the Muslim rule of partible inheritance, the surviving sons tend to develop their individual families in severalty. There are many old and large compounds, therefore, which are occupied by a deceased man's one son or more, and his or their remoter collateral agnate or agnates, a father's brother, father's brother's sons, etc., whose domestic establishments are organized separately, with or without the intervention of dividing walls set up for the purpose. In such cases, the different families within the one homestead are distinguished as different dūd (smoke) or hearths. The individual hearth is the recognised unit of joint housekeeping, ownership, commensality, and domestic privacy. In enumerating households it is usually the hearths which are indicated.

According to the figures already quoted as totals and in terms of percentages, the average (mean) size of the Andarabi household is 7.3 souls, of whom 3.7 souls per household are aged fifteen and above. Among the latter are 0.5 single youths and 3.2 married persons, composed of 1.4 married men and widowers, and 1.8 married women and widows, per household. There are only two types of household fundamentally, although the different demographic stages of their cycles of development, and the occurrence of impermanent accretions, creates an appearance of greater diversity in structure and size. The two

fundamental types are: firstly, the kind of conjugal family which is monogamous, containing only one married man and one married woman at any one time, and concerned primarily to maintain its strength and reproduce itself in the succeeding generation; and, secondly, the kind of conjugal family which is polygynous, with one man married to two or more wives simultaneously, and therefore likely to expand and proliferate in the succeeding generation. It is convenient to name these two types Simple, or small, and Polygynous, or large, respectively. In due course the typical Simple family develops lineally, becoming extended through its one mature son's marriage, or in some cases, where there is no grown son, through one daughter's husband, residing uxori-patrilocally. In either case, one Simple household is succeeded by another Simple household, in the next generation. The typical Polygynous family, on the other hand, grows lineally as well as laterally, proliferating through two or more sons, of whom only one or the other can as a rule attain to a Polygynous household in his turn. The first type corresponds to a stable or fluctuating line of patrilineal descent, the second to an expanding and budding one. It will be apparent that this twofold classification refers to abstract sociological types, since in empirical reality the incidence of demographic chance occasionally shows a small, nuclear family to leave a proliferation of male descendants, while a much-married polygynist can nevertheless bear the opposite consequence. To attain a stable

Simple household is the desire and ambition of everyone, and the common state of men aged in their twenties; large Polygynous households take considerably longer to build up, and can be attained only by the comparatively well-to-do.

In the village of Saiad, which consists of some 77 households, we may divide the extant domestic groups at any one time into at least three categories, on the combined bases of their composition, phase of development, and size.

(i) Simple households (42%), or nuclear families, including incomplete families and nuclear families with a budding or declining accretion (a youth or child who is the husband's brother, or infrequently the wife's brother; or the husband's widowed mother) all of which contain only two (2.0) married or widowed adults (0.9 male: 1.1 female) each. (ii) Polygynous households (33%), consisting of incomplete polygynous families, with or without various accretions; more fully developed polygynous families, perhaps with an accretion; and extended polygynous families, some with the paterfamilias lately deceased. Such groups each contain four (4.1) married or widowed adults (1.5 male: 2.6 female) on average. (iii) The remaining Composite households (25%) consist of the nuclear families of two monogamous brothers who have not partitioned, or of nuclear families which are extended patrilineally, or through a daughter's husband (only extremely rarely a sister's husband), etc. Such households also contain four (4.0) married and widowed adults each, but with an even proportion between

the sexes (2.0 male: 2.0 female).¹

Andarabis can always provide a longish patrilineal framework to the local community of male householders, by specifying several distinct patrilineal lines originating from different male ancestors four or five generations removed, who are sometimes looked upon eponymously by their living descendants.² All the descendants of a remote patrilineal ancestor do not, however, necessarily—or even usually—live as neighbours within one settlement, nor are they defined in terms of regulations of endogamy or exogamy. The actual group of a man's supporters and partisans over a particular issue is either the smaller group of closer agnates, or, at the higher levels, almost his whole local community. With no great exaggeration it can be said that an Andarabi will invariably side with his father and never

- 1 These figures, obtained from Saiad village, are in conformity with the average total size aforementioned. Thus, keeping the male and female proportions distinct: 42% x (0.9/1.1) and 33% x (1.5/2.6) and 25% x (2.0/2.0), equals 1.4 male/1.8 female on average.
- 2 In upper Qasan valley, and in the "hinterland" villages above specified, it is common to find the inhabitants able to sort themselves into half-a-dozen or so khēl (category, faction, group, a troop of men), patrilineally defined. Each particular khēl will be assigned to an eponymous ancestor, e.g. Khēl-i Shukūr, the descendants of Shukur. Everywhere, in his own village, a man is usually identified as the son of his father, or by his own special calling or position; a man will be described as Abdul Aziz-i Sargin, "Abdul Aziz, (son) of Sargin," or as Arbāb Nabi, "Nabi the Headman," or as Yaqub-i Najār, "Yaqub the Carpenter." A man of Saiad village will be identified elsewhere in Andarab as a Saiadi, i.e. "of Saiad," and in the same way outside Andarab he is an Andarabi, "of Andarab."

openly oppose his father-in-law, but that the rights and obligations of all other kin relations are acknowledged as contingent rather than absolute. The patterns of marriage are diverse and heterogeneous, since outside the range of the prohibited degrees, which are fixed patrilaterally, matrilaterally, and also affinally, a man can marry who he will or who he can. The father, older brother, or other close agnate, is the marriage guardian, the legally fixed authority, who arranges the marriage, and is free to commit his ward, male or female, in infancy. About two-thirds (65%) of marriages are arranged within the village in each generation and this, along with the predominance of patrilocal residence (75% of all cases), is the main source and expression of local solidarity.

The contemporaneously effective network of consanguinity and affinity, within which each particular conjugal family moves and has its being, is thus nowhere more than two or three generations deep, and its links do not follow any grooves laid down by the forebears. On the contrary, the legacy and traces of the kinship links which the forebears bequeathed to the living generation become soon eroded and replaced by the force of contemporary choice, demographic fortune, and other social and economic circumstances. The kinship network is thus shallow rather than deep but, from the same causes, it is also wide and all-embracing. There are no regulatory lines drawn separating the population into different marriage groups; only the limits of the anthropologist's

leisure, and of the particular informant's knowledge, prevent him from tracing every Andarabi on one kinship diagram.

The dominant division within society is that between what is public or communal, as against what is deemed domestic, personal and jealously private. The seclusion of women and the privacy of dwellings are the most striking aspects of this underlying theme. The dwelling-houses of every settlement are invariably set apart from the road, screened from the eyes of strangers by high, blank walls, barred gates, trees, and guard dogs. Their privacy from one another is enforced by the same physical obstacles, custom, and the right of resort to armed violence against intrusion and trespass. The paths, fields and pasturages are open and lie in all directions, but the orchards are enclosed and walled, so that women may freely venture and work there. They must not go beyond this, except when properly chaperoned and veiled. There is nothing physically corresponding to a village square, although the local mosque serves thus to the men. Women must pray singly and at home.

Male guests are received and entertained by the paterfamilias outside the domestic precinct, in the special guest-room (mehmānkhānā), or upon a carpet placed in an orchard, or in the communal mosque of the settlement. They are provided with food, or a bedding for the night, there. A close male relative, such as a daughter's husband, from another village, who comes to visit and stay overnight, will

sleep in the guest-room or an inner room vacated for the occasion. Other guests may not see or speak to the women, nor spend a night within the dwelling.

It is Islamic to count two females as equal to one male in regard to their legal rights and obligations. In their public participation, as against their personal rights, females are completely ruled out in Andarab. The men only can own the land and other productive resources, practise cultivation, pasture the animals, go fishing and hunting, attend as required at mosque, government centre and bazaar, conduct purchases and sales, participate in public assembly, etc. From an early age before puberty onwards all females are in purdah, confined to the home and the domestic side of life. Their allotted tasks are rearing children and caring for the family, cooking, washing, cleaning, waiting upon their men, and such activities of production and the care of animals as can take place within the house and yard, namely milking, churning, keeping chickens, sericulture, spinning and weaving. A group of women, working or gossiping somewhere outside the domestic precincts in the village when the men are away in the fields, are quick to veil themselves and become quiet or disperse, at the male approach.

All these restrictions, however, are interpreted realistically and rationally rather than ritually. A girl as well as a boy can herd and water an animal or two, collect firewood from around the village, fetch water or carry messages—while puberty

is not yet in sight. A girl aged thirteen or over, and a grown woman who is a widow, is not without a say in whom she will marry, or to whom she will stay married. A widow with infant children and who does not remarry may own some land, or engage in moneylending, through an agent (yakīl), who must be within the prohibited degrees of marriage. Women own some jewellery as a rule, and they do not part without recompense with any income (e.g. from keeping poultry, sericulture or handicrafts), or an inheritance when such is left to them. According to my observation (perforcedly indirect), the women of Andarab are not the cowed creatures which a mere list of their disabilities might lead one to suppose.

5. The village community

The settlements of a particular village (qariya) do not occur in one compact block, but in the form of several distinct village sections or hamlets (qishlāq), each with its particular name and identity. The homesteads of a given village section are more or less nucleated depending on the nature of the terrain, ease of access to water channels and fields, and the desire for detached privacy. The wealthy and the great show more aloofness from their local group, and set their qal'ah establishments apart. The distance from one village section to another of the same village can be as long as the distance separating two village sections belonging to two different villages along the valley floor. The village

sections and homesteads of the higher altitude villages tend to be more dispersed and isolated. The primary local group (gaum) of the village section is a community of 50 to 150 souls, or, alternatively, six to 20 households, small and large, whose adult male householders are interrelated by kinship ties, who own and work in adjoining fields, and worship in a common mosque.

The composition of a particular village section is most readily described by first distinguishing its native residents from the various incomers, and then dividing up the longer established citizenry patrilineally, as the different localized segments of several distinct and ramifying patrilineal genealogies, of varying depth and extent, whose other segments may be localized elsewhere. In Saiad village 73% of the adult male householders (married men and widowers) are living viri-patrilocally, in the village section of their fathers, while the remaining 27% are living away from the place of their fathers. Among the incomers, 9% had moved to their present village section from another part of Saiad village, 9% are from some other village, usually an higher altitude hinterland village, and 8.5% from outside Andarab district. As regards the degree of intermarriage within the village community (leaving out of consideration the 13% cases where both spouses were immigrants), 65% of the extant marriages had been made between persons of this village, while in 35% marriages one or other spouse, almost always the wife, originally belonged

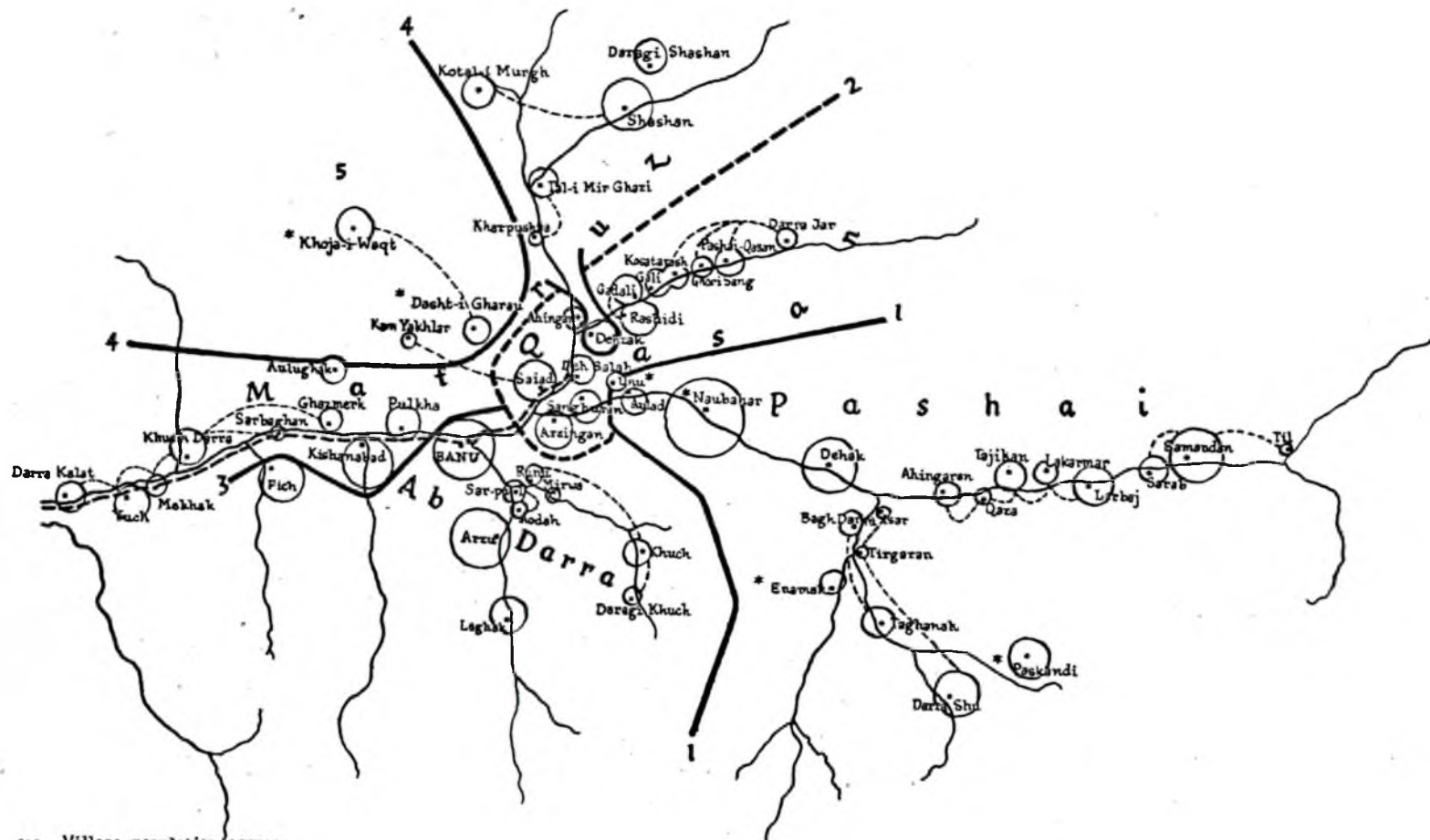

(1) Village population approx. indicated by encircled area.



(2) Single headman indicated.

(3) For six villages marked (*) see text, pp. 39-40, for explanation of headmanship.

Electoral ward boundaries:		Registered male souls:	Central lowland villages:	Registered male souls:
1-1, & 5	PASHAI	5,530	Naubahar	1109
1-2	QASAN	2,665	Saiad (313), Arzingan (309), Sangburan (261), Deh Salah (217)	1100
1-3	BANU & AB DARRA	2,734	Banu	752
2-3, 4-4	MAFRUZ	3,367	Kishanabad (502), Pulkha (284), Dehzak (265)	1041
		<u>14,296</u>		<u>4,002</u>

Map 3 Andarab (village headmanship & electoral wards)

to a different village. Sixteen per cent marriages were with the father's brother's daughter, brother's widow or father's brother's widow, constituting what may be called the most parochial form of marriage. We may conclude from these figures that the network of agnatic as well as non-agnatic kinship is interwoven most intensively within the village community, but also extends beyond the village borders radially in different directions.

The total population is distributed among some 55 named villages, with an average (mean) size of 600 souls per village, but varying widely from 140 souls in the smallest village, to 2,500 in the largest. The majority (32 villages out of 55) fall within the range 200 to 600 souls. The average village contains about 80 households; the smallest has only 20 households, and the biggest 350 households.

The largest villages exhibit but a diffuse unity among their several sectional settlements in ordinary communal affairs, and are often divided under two or more village headman, either de facto merely or even in the reckoning of the district administration. The smallest villages and the hinterland settlements are officially grouped in twos and threes or more, under a single headman. An isolated hinterland village is attached to its nearest lowland neighbour, e.g. Kam Yakhlar to Saiad. Map 3 shows Andarab's 55 villages (qariya) distributed among 32 officially recognized village headmen (qariyadār, arbāb), as at mid-1960 date. In the

allocations of four of these headmen requires an explanation. In 1959 Naubahar, the biggest village, counted its sedentary Tajik households (one-quarter) under one headman, and its pastoral Hazara Dala households (three-quarters) under three headmen, who each had their own following also in their Paskandi aylāq (see above, pp. 18, 28). During the annual tour of the district in 1960, the then Deputy Commissioner (HAKIM X) insisted on a general reduction in the number of village headmen, and was particularly adamant in the case of Naubahar and Paskandi. A reshuffle ensued in which other villages became involved, and at the end of it (1) HEADMAN I emerged accredited with the Dalas of Naubahar, plus one part of Paskandi, plus one half Khoja-i Waqt and Dasht-i Gharau (see map); (2) the Tajiks of Naubahar remained with HEADMAN II; (3) the remaining part of Pashandi remained with its HEADMAN III; while (4) a new HEADMAN IV took on the remaining half of Khoja-i Waqt and Dasht-i Gharau, along with Unu (near Naubahar), and Enamak (near Paskandi).¹ These people (4) in Khoja-i Waqt and Dasht-i Gharau, Enamak and Unu, were originally poor immigrants from Panjshir (see Map 1), making a living in the interstices of Andarab, and they still maintain their marital and other links with one another. Aulughak and Kam Yakhlar are also Panjshiri settlements.

1 All four headmen and all six villages were thus included in the Pashai sub-district (as shown on Map 3), whereas one half of Khoja-i Waqt and Dasht-i Gharau were formerly attached to Mafruz, in the lower part of Andarab.

At one time all Panjshiris in the district recognized a single headman, but the above episode (and the allocation e.g. of Kam Yakhlar to Saiad), is an illustration of the process whereby with time their different local affiliations start to cut across the inherited "ethnic" unity. The local loyalties must eventually prevail, except as where modified by some occupational unity, e.g. as pastoralists in one aylāq like the Naubahar Dalas.

The local community is called qaum at any particular level, village section or village, sub-district, district, etc., and local affairs are described as gaumdāri. Village affairs are subject to free discussion, and perhaps conciliation, in the public assembly (majlis, jirgah) of elders (rīshsafēd, greybeard), in which any and every villager may sit, but outsiders usually cannot. The deliberations of such village councils have no binding power upon disputants, however, so that they commonly also have recourse to the administration. The obligations of village membership are of three different kinds: (1) those for which the people are answerable to officialdom, such as the appointment of an headman, the upkeep of roads and paths, delivery of conscripts, defaulters and offenders, meeting levies of grain, official hospitality; (2) those for which the community is answerable to its religious conscience, namely to erect one mosque—and one only—in each village section, and contribute jointly to maintain its mullah, who is the local Islamic legist, and

mosque prayer leader; and (3) duties of mutual help and interest customarily owed by one villager to another, which include intermarriage, attendance at one another's marriage feasts and funerals, upkeep of common water channels, defence of common pastures, harvest help, etc. Each village section has its own graveyard, and occasionally its favoured wayside grave shrine (ziyārat), with mild associations of special blessing ('ibādat). Villagers often contribute jointly to hire one or more herdsmen to graze their animals other than sheep, in the spring and summer. A barber (khalīfa) will count a number of villages as his regular clients; and besides shaving male heads and trimming beards, he also pulls teeth, lets blood, and circumcises boys.

The village headman is appointed by agreement between the people of the village and the administration and his main charge is to act as the accredited intermediary between them. He is preferred by the administration to be able to read and write, and possess enough property to stand surety nominally when he is made to collect levies or even revenue. He must possess sufficient wherewithal to entertain minor officials, down to the lowliest gendarme, who call in the village; once a year when the Deputy Commissioner himself goes on circuit, grander receptions are in order. A village takes a new headman at any time by submitting an agreed nomination signed or impressed with a seal by a number of greybeards, to the Deputy Commissioner. Village headmen attend frequently at the district

secretariat in Banu, and form the main channel through which the people can safely approach officials on any matter. The headmen help the administration to keep the peace, report crimes, deliver defaulters, supervise the payment of taxes, make assessments of property when required, witness all sales of land and official marriage contracts when such are obtained, organize road work, etc., etc. In return for the services rendered to the administration, the village headman is informally licensed by the district officials to retain fees of commission from the people for whom he is responsible, and whose briefs he frequently advocates. Otherwise, a village headman usually collects in one year only a small amount, say 20 - 30 afghanis, per household from his constituents. He is also entitled to collect his expenses incurred in representing the community. Altogether, however, every village headman does not always find the occupation lucrative, and the position is as secure and influential as its possessor. A village headman may resign or be removed in the space of a year or two, but if agreeably entrenched he may continue in his position for a very long time. The status is not necessarily hereditary.

A village headman must fulfil certain pre-conditions if he is to be successful. He should be personally well-to-do, with a large household, preferably polygynous, so that he can count on some interested allies within the village or outside it, and have sons who can carry on the domestic work and cultivation etc., which sustain his household estate, while

he engages in the business of headmanship. He should possess presence, to instil respect for his opinions in councils, and be able to advocate causes and courses effectively. Above all he must possess a group of agnatic supporters, that is, brothers, brothers' sons, or father's brothers, who may also be, or expect to become, affinally related to him in some way, and who are his first party of support in the local community after his own sons. A lone figure, no matter how well qualified on other grounds of wealth etc., will never be acceptable as a leader and representative. Andarabis express this by saying that a headman should be of "good lineage (nasab)," i.e. his father or elder brother or at least his father's father should have had some standing in the community— if only the demographic standing of having had many male offspring. Otherwise, informants said, a man would need to expend much cash in winning support and even more in keeping it; and where would he have found that, since a village headman must be a local man? In other words, it all takes more than one generation, since procreative fruitfulness cannot be quickly purchased. Often enough there is more than one possible contender in a given village for the position, though it might not be to every competitor's inclination to declare himself a candidate at a particular time. Eventually, over a long period of time, the position can be said to simply circulate by a mixture of competition and accepted rotation, among the several older or wealthier men of a locality who are also

genealogically placed fortunately on or near the burgeoning points of particular lines of patrilineal descent.

It may be noted here that all the above requirements hold generally for all situations of leadership in Andarab. In a milder measure, they apply also to any grey-beard who carries weight in his locality. The only man in the community to whom they do not apply in the same proportions, is the mullah or learned of Islam; but his authority and influence are of a different kind altogether.

6. The community of Andarab district

The written records of men of many civilizations, ancient Greek, ancient Chinese, medieval Arab and Persian, Mughal Indian, Turkish, modern Afghan, and early nineteenth century British, notice Andarab at one time or another; and an inventory could be compiled covering almost all historical periods, up to the twentieth century, even without the aid of archaeological and numismatic data.¹ The chroniclers are

1 Some famous conquerors have passed through the valley: Alexander the Great (W. W. Tarn, Alexander the Great (Cambridge, 1948), p.66); perhaps Ghenghis Khan himself, certainly his armies (W. Barthold, Turkestan down to the Mongol Invasion (London, 1928), p. 444; Tamerlane (e.g. Sir Thomas Holdich, The Gates of India (London, 1910), p. 355 ff.). Humayun, later Mughal Emperor, fought two engagements in Andarab, in 1546 at Tirgaran, and in 1547 at Ab Darra, and also reorganized his army there (Ishwari Prasad, Life and Times of Humayun (Calcutta, 1956), pp. 254, 262, 295).

The final conquest of Andarab by the Afghans in 1859 is described by Amir Abdur Rahman (Amir, 1880-1901), the great centralizer, in his autobiography (Mir Munshi Sultan Mahomed Khan, ed., Life of Abdur Rahman, (London, 1900), pp. 14-15). The most extensive account of the district is the one in Persian above quoted for its population figures (Burhanuddin Kushkaki, Rahnumā-i Qataghan va Badakhshān (Kabul, 1925), pp. 44-56), which was collected during the tour of another great general, Nadir Shah, who became King of Afghanistan.

usually in broad agreement about what they remark upon, but we are concerned here with one particular point only, as to whether Andarab was ever the seat of a nucleated town, and when. The Chinese Buddhist pilgrim Hsüan-tsang passed that way in 644 A.D., and wrote that "the capital is 14 or 15 li round", which must mean a circumference of 1.5 to two miles at least.¹ After him came the period of Arab Muslim domination, from 740 A.D. onward. In the tenth century, the Arab geographers reckoned Andarab as "the third town in Tukharistan",² and "having fine markets".³ The Hudūd al-Ālam, or Regions of the World, a Persian geography also of the tenth century, describes it as "a borough amid mountains": "It is a place with much cultivation, (producing) much grain. It possesses two rivers. Here dirhams are struck from the silver extracted from the mines of Panjshir and Jariyana. Its king is called Shahr-Salir."⁴ Finally, the Moorish traveller Ibn Battuta, who enjoyed in Andarab in 1333 A.D. the special hospitality reserved for a man come from the country of Muhammad, stated

- 1 Stanislas Julien, Le vie de Hiouen-Thsang (Paris, 1853), p. 362; Thomas Watters, On Yuan Chwang's Travels in India, 2 vols. (London, 1904), ii, 268; Samuel Beal, Chinese Accounts of India: Translated from Hiuen Tsiang, 4 vols. (Calcutta, 1957-8 ed.), iv, 472.
- 2 The first and second towns being Taluqan and Qunduz (Map 1), and Tukharistan approximating to the modern Qataghan province: W. Barthold, Turkestan down to the Mongol Invasion (London, 1928), p. 67.
- 3 Guy Le Strange, Lands of the Eastern Caliphate (Cambridge, 1905), p. 427.
- 4 V. Minorsky, trans., Hudūd al-Ālam (London, 1937), pp. 109, 341.

that "in former times there was a town here whose traces have disappeared".¹ The topographically suited site for such a town would be the Deh Salah plain, but there are sound strategical and other reasons to suppose that it was in fact situated at Kishanabad, where the ruins of a considerable fortress still remain. The later travellers who, mentioning Andarab en passant, write of reaching "the city of Andarab", when they had arrived at one or other of its settlements,² are merely so rendering the original shahr, when it would be better rendered as "borough".

In any case, whatever one may make of the historical testimony, and whatever the verdict which might be eventually given by the archaeologist's spade, there are to be found today a number of institutions and characteristics which provide the borough with the quality of an urban community. I merely list these here below, with the preface that their general social consequence is to further heighten the geographical contrast already drawn between the "lowland" versus the "hinterland" villages.

-
- 1 Ibn Battuta, Travels in Asia and Africa, trans. H. A. R. Gibb (London, 1929), p.178.
 - 2 E.g. see A. Vambéry, Travels and Adventures of the Turkish Admiral Sidi Ali Reis during 1553-1556 (London, 1899), p. 66.

(1) The organization of the district as one administrative entity (hukūmat-i mahalli), visibly indicated by the district secretariat's site in Banu (hukūmati), including the Deputy Commissioner's residence and office, the primary Judge's court, the magisterial lock-up and local gendarmerie quarters, etc., in what was formerly a large private gal'ah (castle). Individual Andarabis have all too frequent recourse, in the common opinion, to the various departments of civil administration there. Village headmen and some others are obliged to attend regularly. The particular organization and functions of the district secretariat will be described more fully in Chapter V.

(2) The official status of Andarab as a single electoral borough, returning one Deputy (vakīl) every three years to the National Assembly in Kabul, and one to the Provincial Council in Baghlan. Both elections are held at the same time, and invariably accompanied by wide intrigue, backstairs negotiations, as well as public assemblies. This was the case at the last general elections in 1961, notwithstanding the fact that the only candidate declared for the National Assembly was the official nominee, and only a token election was staged for him. The election of the provincial deputy, in contrast, is usually left to the people's choice, and this proved during 1961 to be a most contentious proceeding. The two deputyships are respected partly for their own value, and also because they provide proximity and access to

the officials with appellate powers in the national and provincial capitals. The provincial deputy particularly can catch the ear of officialdom in Baghlan, and make himself the most effective channel of representation. A prominent Andarabi, DEPUTY X, who somewhat exceeded himself in this capacity, was caused to be unseated in 1960 by the province's GOVERNOR, and charged formally with sedition, for which he was sentenced to fifteen years' imprisonment.

(3) Apart from the deputies who sit in Kabul and Baghlan, there are also some stipendiary municipal posts, connected with functions performed for all Andarab. A Town Clerk (kātib-i tanzīf, or raīs-i baladiyah) is selected every three years, usually from Banu. He has under him the two Bazaar Headmen (kalāntar) of Banu and Deh Salah, a Town Crier, and one Footman. He is concerned primarily with whatever regulation the bazaars need, and their general cleanliness and presentability; he has a modest budget for the purpose, collected through levying shopkeepers and tradesmen, and the lease of the Deh Salah grain market. This municipal revenue also ~~redistributes~~ **redistributes** the small official stipends which are paid to the Imam (Prayer Leader) and Muezzin of the congregational mosque (masjid-i jāmi') in Banu, recognized as the official mosque of the district; and to another minor religious functionary, the Public Censor (muhtasib), who reports to the Qazi (Judge of the Primary Court) in Banu.

The district secretariat Treasury is also kept in the charge of a local man, the Treasurer (khazānādār), appointed aperiodically after popular consultation. He is a subordinate of the secretariat's Revenues Officer. Similarly, a local man is appointed as Warehouse Master (gōdāmdār), in charge of the annual grain levy (gōdām). He has under him his own Warehouse Clerk and one Weigh-man, locally recruited.

The functions of the Town Clerk, Treasurer and Warehouse Master are to assist the administration, but they are free to act in a representative capacity also. They are reckoned as local officials.

(4) There is a sizeable educational establishment in Andarab, which falls naturally into two parts, the state schools and the Islamic seminaries.

The Ministry of Education supports three senior primary schools, teaching boys up to the sixth grade (aged thirteen to fifteen), and two junior "village" schools, teaching up to the third grade only. The senior schools are situated at (i) Banu: 460 boys, ten teachers (mu'allam), one head teacher (sar mu'allam); (ii) near Deh Salah: 450 boys, ten teachers, one head teacher; and (iii) upper Qasan: 260 boys, five teachers, one head teacher. The "village" schools are at (iv) Fich: 60 boys, one teacher; and (v) Shashan: 70 boys, one teacher. Some school teachers are natives of Andarab, some (including the head teachers) are from elsewhere. Their appointments and salaries (paid through the Banu treasury)

are controlled by the Kabul Ministry of Education, through the provincial Director of Education. School books and materials are also supplied by the central Ministry. The school curriculum is: Koran and religion; Fārsi (Persian), and in the later grades Pashto; writing; arithmetic, algebra and geometry; history and geography; health and hygiene; civics; agriculture; handiwork.

The Islamic seminaries are quite different. There are at least eleven of these, known as madrasa, distributed throughout the valley in different villages.¹ Each of them consists of one maulavi (one especially learned of Islam, a superior mullah), training a small group of ten or a dozen pupils (tālib), on his own and their initiative, to become village mullahs. Their curriculum is centered on Koranic exegesis, Muslim theology and eschatology, commentaries of shari'at, the ritual and legal requirements of Islam, inheritance, marriage, etc. The pupil mullahs of these little seminaries are local youths as well as some from places outside Andarab; and they expect to find local employment. They are all supported by the voluntary contributions of the village. The leading maulavis of Andarab (in Sangburan, Deh Salah, Kishanabad, and Tal-i Mir Ghazi), are men of Panjshiri origin, who had themselves received some years' training in Peshawar (Pakistan), when that city was in British India. Their text-

1 Kishanabad, Banu (two), Sangburan, Deh Salah, Aulad, Naubahar, Dehak, Tajikan, Tal-i Mir Ghazi, and Shashan.

books are such as were commonly printed in Peshawar, Lahore or elsewhere in what is now Pakistan; occasionally in pre-revolutionary Bukhara; only rarely in Kabul.

(5) The best evidence of the reality and coherence of Andarab at the supra-village level is not to be sought, however, only in the officialized statuses so far enumerated. It can be said to rest rather with an amorphous group of men of parts, established land-owners and prominent persons, natives of particular villages, who together constitute an informal body of "town councillors". They are active as leaders and representatives of their own local community in much the same way as the ordinary village headman is, but they are acknowledged to possess a greater competence, wider following, and extensive connections, which entitle them to take precedence in the conduct of business, affecting the larger community. It is because of their presence and position primarily that one may speak of Andarab district as a whole possessing a considerable measure of municipal self-government.

A few of them might be village headmen themselves, and such a position is often held in their village of domicile by someone related to them in one way or another, but the more prominent figures have either attained some more elevated post within Andarab, national or provincial deputy (vakil), local treasurer (khazānādār), town clerk (rais-i baladiyah), or warehouse master (gōdāmdār); or have served

the state in some capacity outside the district, as judge (qāzi), juriconsult (mufti), secretary (mirza), chief clerk (sar Kātib), head teacher (sar mu'allam); or have made the pilgrimage to Mecca (hājji). Their personal names are commonly found prefixed by such titles; and they are also referred to politely as So-and-so Khān, although this latter term can be suffixed out of courtesy to anyone's name. The substantive Khans can be distinguished readily by their maintenance of sizeable guest-rooms, and the appurtenances and largesse of hospitality, even more than by the size of their residences (qal'ah). A Khan's guest-room is usually occupied by visitors of the night, who are local people as well as travellers of all shades. No official or visitor of some distinction can depart Andarab without royally guesting with one or more of them. One can learn the affairs of Andarab and the world better here than in the common marketplace of the bazaar, or from the gossips who frequent the district secretariat.

The foremost Khans of Andarab are somewhere between a dozen and twenty in number at any one time. They are the wealthier, older and wiser men, of "good lineage", and good Muslims, whose prominence is sustained by possessing much the same characteristics as a village headman, only in greater measure: property; a large polygynous household with many children; a large and maritally close-knit group of near agnates, some preferably themselves men of standing and

substance; personal character and skill in advocacy; honourable partisanship in local affairs; and effective relations with the administration. The Khan's own multiple marriages, and those which he arranges for his sons and daughters, are important indicators of the strategy of alliance.

The incorporation of Andarab district under the central Afghan government dates from its military conquest in 1859.¹ The first civil Deputy Commissioner (Hākīm) was appointed soon after;² but the independent powers of the titular Mīrs, the former rulers of Qataghan and Badakhshan, were not finally broken until their severe punishment and dispersal at the hands of Amir Abdur Rahman, 1880-1901.³

1 See p.45, n.1, above.

2 Burhanuddin Kushkaki, loc. cit.: p.45, n.1 above.

3 At that time the great power in Andarab was said to have been one Mirza Gharib, who owned much land. He was a partisan of Ishak Khan's northern rebellion in 1888, and after its collapse he (Mirza Gharib) fled beyond the Oxus to escape his life. The Amir Abdur Rahman subsequently bestowed Mirza Gharib's lands upon one Malik Safed Nuristani, who had been a malik in Nuristan when it was pagan Kafiristan, and had aided the Amir in its conquest and conversion to Islam in 1896.

Malik Safed, who did not himself reside in Andarab, was later assassinated, and his Andarab grant is now divided among the four sons (living) of his younger brother. They are Andarab's only absentee land-owners of substance. One of them is a retired General living in Kabul; another is (1961) the Commandant of Gendarmerie in Baghlan. The four brothers inherited 40 acres each near Deh Salah and Sangburan, but some of this they have sold to local purchasers. The remainder is in the charge of a local overseer.

During the reign of that monarch Andarab district was sub-divided into four administrative wards (dasta, bundle), each one in the charge of a native Nāib or Deputy, who was responsible to the Hakim for the collection of revenue, the annual grain quota, etc. The four Nāibs had numerous village headmen under them in turn. The system of Nāibs was officially discarded under King Amanullah (1919-1929), when the centrally appointed administration was further elaborated, but the needs which their position answered are still felt. Some of their descendants are important people today.

The four sub-divisions of Andarab continue to be actively recognized whenever the district is required to be officially represented by a small group of responsible individuals. This is particularly so during the political manoeuvres for the general elections, when the people of each ward first attempt to determine their own candidate before submitting him to the general consensus, or for official acceptance. Each electoral ward also tries to ensure that, over the period of consecutive elections, the successful candidature is rotated equitably among the different wards. Again, at the time of calling up national service conscripts, or delivering the Army's grain levy (gōdām), every year, responsibility is more conveniently fixed upon four individuals, selected one from each ward,

instead of being distributed widely among all the thirty or so village headmen. The electoral wards, intervening between the level of the single village community and the unit of Andarab as a whole, are important—or indeed essential—political sub-divisions of the district, considering its large size and the awkward conditions of its internal communications.

The boundaries of the four wards (said to have been fixed in Amir Abdur Rahman's period) are shown on Map 3. Three of them are named after physiographic entities (Pashai, Qasan, Banu and Ab Darra), whereas the fourth, Mafrūz, bears a name with the meaning "enjoined (by law), assumed, granted". Their physical allocation is as follows. (1) Pashai: Unu, Aulad, Naubahar, and all the upper hinterland villages, plus also Khoja-i Waqt and Dasht-i Gharau in the north-west (see above, pp. 17, 40, 40n.). This is physically and in population the largest ward. (2) Qasan: Saiad (including Kam Yakhlar in the hinterland: pp. 39, 41 above), Arzingan, Sangburan, Deh Salah and Ahingar, grouped together as "lower Qasan" (Qāsān-i pāiyān), and all the villages of "upper Qasan" (Qāsān-i bālā), i.e. Rashidi and above. The village of Dehzak, the physical connecting point between upper and lower Qasan, is excluded. (3) Banu and Ab Darra: all the villages on the southern tributaries which join in Ab Darra and debouch into the main river at Banu, plus another group of settlements (Fich) in a southern side-valley, which is not contiguous to Ab Darra.

The southern valley (Sar Darra) which is contiguous, and the village situated at its mouth (Kishanabad), are allocated to the fourth ward. (4) Mafruz: comprising the remainder, Pulkha, Kishanabad, and the six villages (excluding Fich) below, hinterland Aulughak, the village of Dehzak excluded from Qasan, and Tal-i Mir Ghazi, Shashan and Kotal Murgh.

To understand the meaning of this distribution, and the principle by which particular villages are included or excluded, we must take into account the geographic and other characteristics explained earlier. The foremost fact to be borne in mind is that most of the rich alluvial soil and irrigated arable of Andarab is concentrated in the "lowland" centre of the district, at an altitude of 5,000 ft approximately (cf above, pp. 23-23). It occurs in a large Y-shape, laid flat upon the river system, with its one arm pointing along Saiad, Deh Salah and Dehzak; its second arm along Arzingan, Sangburan, and up to Naubahar village; and its stem pointing downstream to Banu, Pulkha and Kishanabad. Now what the ward boundaries accomplish in effect is to allocate the nine "star" or "head" villages so defined into four compartments of roughly equal population: (1) Naubahar, the village on the east extreme of the "Y", with 1109 registered male souls; (2) lower Qasan, four contiguous villages at the centre of the "Y", totalling 1100 registered male souls; (3) Banu, the centre of administration, with comparatively fewer, 752, male souls; and (4) Pulkha and Kishanabad, two

contiguous villages at the lowest point of the "Y" downstream, along with Dehzak at its uppermost, northern end, totalling together 1041 male souls. The next step of the allocation is to then attach to each "star" village or villages a "satellite" group of villages, to give each "head" also a body and tail, without doing violence to the facts of geography, communications, and ecology (cf pp. 13-16, 17-19 above), and so equitably distribute all resources, good or bad.

Thus Naubahar and Pashai, comprising the largest territory and population, do not possess much of the "lowland" arable, and are farthest from the seat of administration, the commercial centres and the schools. Banu and Ab Darra, which are closest to these amenities can muster only a small population; and this is augmented (rightly) by the poorer valley of Fich rather than the richer village and valley of Kishanabad. Lower and upper Qasan, which are also closer to the "centre" and otherwise well-provided, have Dehzak elided from them and enjoined upon Mafruz. Their comparatively good land is compensated also, by less extensive pasturages than the other wards. Mafruz, finally, is so made up to possess something of everything, and a bigger population than either Banu and Ab Dara or Qasan, but less close and compact than they.

The ethnic composition also happens to be balanced in this allocation. The pastoralist and migratory Hazara groups

fall into three wards: the Dala of Naubahar and Paskandi in Pashai; the Qurghuli of Kotal Murgh and Shashan, and the 'Abaqa of the six lowest downstream villages, in Mafruz; and the Quzi of Arzu, etc. in Banu and Ab Darra (see pp. 28-29 above). The immigrant Afghans and Muhammadzai Sardars settled in Khush Darra, Banu, Arzingan and Saiad (see p.28), find themselves in Mafruz, Banu and Qasan wards.¹

It will be apparent from this account that the district could not be carved up into four quarters more justly. The territories of the four wards are so defined as to cut straight across the geographic, economic, ecological and ethnic divisions which were outlined earlier. Each ward is therefore a minature Andarab in all important respects. I have detailed the evidence for this not merely to conjecture how the seventy or so years old division was historically arrived at, but to point to the obvious conclusion that the political sub-divisions of Andarab district follow territorial lines, and the principle of matching the territories as far as possible. I need hardly stress that this design is the exact opposite of one which would follow economic, occupational or ethnic principles.

1 The land still held by the absentee Nuristani brothers lies near Sangburan, at the point dividing lower Qasan from Pashai: see p.54 n.3.

7. The grades of society

Andarabi society cannot be said to contain social classes arranged in an hierarchy, or any system of corporate groups. Marked disparities in wealth, occupation, influence and prestige can be observed to exist among the individuals, but without their express formulation within the social system.¹ The Afghan state is not a feudal organization with pre-determined and ranked estates; and Islam in Afghanistan is the religion of the individual and the local community, taking no cognizance of social sub-groups. The Koranic law of partible inheritance, along with the consequence of a multiplicity of heirs created by polygynous marriages among the well-to-do, acts to dissipate rather than preserve and transmit accumulated wealth from one generation to the next.

We are concerned here with a culture wherein social differences are based upon a system of individual positions and personal precedence, attained through competitive leadership. The general pre-conditions of achievement were mentioned before in connection with village headmen and Khans.² A man can advance himself in life by obtaining official (state)

1 The "craft guilds" which are remarked to "flourish in Tajik villages", by the Human Relations Area Files symposium on Afghanistan (D. N. Wilber, ed., Afghanistan (New Haven, Conn., 1956), p.210), are certainly apocryphal.

2 Pp. 43-45, 53, above.

patronage; or as a representative of religion, education or piety in some form; or through commerce. Such paths which can earn riches, usually take the individual outside Andarab district, at least for a period, and conversely draw outsiders into it, often enough for permanent settlement. However, within the Andarab community, the cardinal source and expression of local prominence is not wealth itself but the capability to claim the support and following of some local group, howsoever small. The nucleus and starting point of local support, can only be the individual's near collateral agnates, and, secondly, affinal relations who are also neighbours. Even the smallest agnatic group of merely two brothers, and those in severalty, can readily prevail in local affairs over a lone man who possesses greater property in sole heirship. In itself, and without the addition of manly numbers, wealth constitutes a quiescent potentiality merely.

With these necessary provisos in mind, one can say that Andarabis do differentiate those who are rich and engaged in leisured, honourable and lucrative occupations, from the common herd, and contrast them against poor men, employed in laborious or mean tasks. In day to day affairs, precedence in company, small personal services and prestations are customarily given and received, and constitute the hallmark of the individual's status within the community. The majority

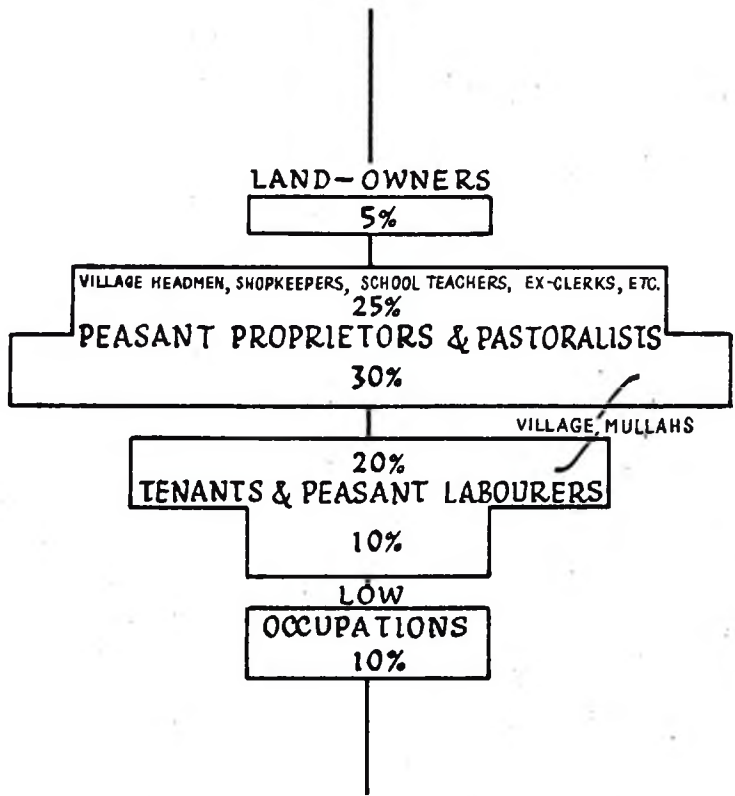

Fig. 2 Schematic socio-economic strata

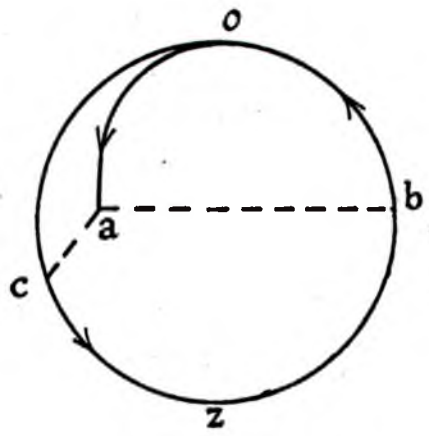

Fig. 2a Paths of individual mobility

of Andarabis are peasant proprietors and pastoralists of independent means and egalitarian spirit but, upon the criteria of wealth, income and occupation, they can be said to grade all Andarab into four social strata. These are conveniently termed as: (1) Khans, landowners; (2) peasant proprietors and pastoralists; (3) tenants and peasant labourers; (4) those engaged in low occupations.

(I) At the top of society are the Khans, the biggest landowners (with 50 or more acres of ābi irrigated arable), moneyed, well-connected, hospitable and with wide repute. They number only a few per cent. Their political status, representing the ward rather than the village, and the offices open to them, have already been mentioned in the preceding section. A learned Maulavi who runs a small seminary, and the occasional well-to-do, reputable Sayyid (descendant of the Prophet), will also rank with them. The predominantly pastoralist Khans of Pashai ward also rank as such, although in Andarab generally the more settled and leisured land-owning life is preferred. Altogether, this grade of the "great of the community" is the smallest and the most difficult to attain.

The Khans need not ever put their own hands to the plough, or labour in other ways, although their sons and younger brothers may be practising agriculturists. (The servant engaged in personal or domestic service is unheard of.) They employ a few share-cropping peasant labourers (dehqān) and

others to perform such duties for them. All like to possess fine horses, cattle, a herd of sheep, and some goats; a large castellated house (qal'ah), set a little apart, with reception rooms with a view and a small mosque for the daily prayers; fine carpets, guns and rifles, a wireless, etc. Almost all augment their annual cash income through money-lending to some degree, and many engage in bazaar trading, but without tying themselves to sitting keeping shops. One Khan owns a lorry, plying passengers and goods to Pul-i Khumri, sometimes Kabul, and three others own shares in a second lorry similarly employed.

(II) The most numerous economic grade consists of middling land-holders and pastoralists, sub-divided into those who own enough means only to ensure their livelihood in independence, and those who possess more besides and can engage in competition (raqābat). The latter are the ones with more swagger (kākagi, kalānkāri) than grace, regarding themselves as "five-quarters" (panj-chāarak). Prominent among them are village headmen (and intending village headmen), village greybeards, ex-government servants, school teachers, and shopkeepers. A village mullah is included here only if he is an appreciable land-holder as well. All men in this grade, comprising somewhat over one-half the population, possess from five to 30 acres arable, ābi or lalmi, per head. They are the "people of Andarab", no one of them to be lightly ignored.

(III) Just below is the third grade, comprising perhaps one third of the population, of "dependant" proprietors (nādār, indigent), who own only small amounts of ābi and lalmi land (0.5 to five acres per head), and an inconsiderable number of animals. They are obliged to work for others as share-cropping tenants (chārikār) or peasant labourers (dehqān); or earn an income from skills of little prestige. The trades of bazaar, baker, butcher, blacksmith, corn-chandler, greengrocer, and village carpenter or mason, are here included. Itinerant village mullahs, who possess no land in the village, also fall in this grade.

The tenant share-cropper (chārikār), who is himself a minor proprietor, contributes the labour, the agricultural implements and draught oxen, while the owner provides the seed grain. The produce of the fields is divided annually, customarily three-quarters to the owner and one-quarter to the tenant. Such tenancy is called chārikāri, meaning "quarter-working". It is usually done on a year to year basis, for someone in the village who does not wish to engage in cultivation, or has some other occupation, or no draught oxen. It is different from the peasant labourer's contract, whereby the owner provides all the materials and the dehqān only his labour, taking one-eighth (or one-fifth on dry-farming lalmi) of the produce for it. Such dehqāns are often poor and single men, who must go through this stage in order to marry and set up house at all. They do not necessarily

belong to the owner's village, and are customarily given shelter, a suit of clothing and food by him. The dehqān frequently has nothing to call his own, but will almost invariably have a father or an older brother somewhere, possessing at least some dry-farming fields, a part of a homestead and a few mulberry trees. There is no surplus of easily obtainable labour within Andarab, and a good dehqān is hard to retain for long.

This third grade consists of people and occupations of "small repute", but still honourable: "people will give daughters to these" including the dehqān.

(IV) The last and lowest grade is composed of the landless poor engaged in "mean" occupations, with little or no chance of improvement, viz. cattle and goat herder (a shepherd being rather the same as the dehqān), a donkey driver, oil-presser, water-mill minder, mazdūr (day labourer, paid in cash), shoemaker, skinner, or (worst of all) barber. Andarabis are generally disdainful of such occupations, and regard them as fit only for bēwatanha, persons without domicile. A number of the poorest immigrants in fact start as such, if not as dehqāns. Altogether, persons of this grade must usually marry amongst themselves, and are not permitted to venture opinions on village affairs. The homesteads of the few barbers, the only really polluting trade found in Andarab, are set apart, so that they need not join the mosque congregation too often. As a whole this grade

TABLE 1

Ownership of irrigated (ābi) land

Saiad village

N = 108 adult householders (married men/widowers)

Socio-economic grade:	Per cent householders:	Per cent land owned:	<u>Land-holding per capita of owners:</u>	
			Mean:	Range:
I	4	22.3	23	6 - 35
IIa	27	45.2	6	2 - 20
IIb	34	26.0	3	0.5 - 10
IIIa	17	6.0	1.5	0.5 - 5
IIIb	9	0.5	0.5	0.5
IV	9	- -	- -	- -
	<u>100</u>	<u>100.0</u>	<u>Total = 402 acres</u>	

numbers about five to 10 per cent of the population. It formerly included also weavers and cotton-carders, whose trades are now defunct. Visiting gypsy-hawkers (qawwāl), and goat-herding Gujars,¹ are classed with this grade.

I may here conveniently illustrate the economic strata specified above with some data on land-ownership from a particular village. In the village of Saiad there are living 108 adult male householders, i.e. married men and widowers; and the total irrigated arable (ābi) of the village is 402 acres. On a combination of socio-economic criteria the 108 householders can be divided into six grades (I, IIa & IIb, IIIa & IIIb, IV), with their resultant proportions as shown in the second column (Per cent householders) on the Table opposite. The different proportions of the ābi land which are owned by the different classes are shown in the third column (Per cent land owned). A total of 82 householders (80%) are ābi owners of one kind and another, and the sizes of their individual holdings are indicated by the two final columns. They are reckoned per capita in this table. For example, the largest single holding in Saiad is about 50 acres, owned by an old married man and his young married son,² who are reckoned here as owning 25 acres per head.

1 See p.16 above.

2 Two older unmarried sons, presently in employment outside Andarab, are also heirs to it. The fourth and oldest son separated from his father and brothers, obtained his inheritance and set up independently many years ago—a rare proceeding during a father's lifetime. This oldest brother is still domiciled in Saiad, and is reckoned independently in Table 1.

Table 1 explains the position in Saiad with regard to the ābi land only. If the distribution of the non-irrigated lalmi was to be similarly tabulated, it would show the lower grades to be rather more favoured than here appears. The ownership of non-arable property is more difficult to reckon simply; it includes a variety of possessions whose value is not readily inter-convertible by a single yardstick. In the Khan's case one can safely omit to list an oil press or water-mill and not worry to count his carpets; but when we get down to grades IIIb and IV, one must attempt to assess the value of part-homesteads, the ground on which they stand, and the odd productive cow or mulberry tree. Pastoral wealth is similarly difficult to compare against landed wealth. In this Saiad series, since there is only one considerable pastoralist (an incomer from Pashai, owning 500 sheep and goats), who is also a middling land-holder, the mere count of the ābi land is sufficient as a single measure, albeit an approximate one.

There are more serious grounds on which the above general account can be said to be an over-simplified picture, for it necessarily ignores the vital factors of the individual's household structure and development. In such demographic respects the socio-economic strata of Andarab exhibit a characteristic one-sided and top-heavy quality, which is profoundly relevant to any discussion of social mobility. As was described before, multiple marriages and extended polygynous households are widespread among the upper strata of society.¹

¹ See pp. 27, 30-32 above.

Many men are married early, at their father's arrangement and expense, and marry again and again at intervals, as and when their circumstances favour.¹ The uppermost end of society consequently constitutes an over-productive "source" of population (Fig. 2a, point "o"). Now, there are two corollaries to this phenomenon. Firstly, since the relative proportions of the different socio-economic strata remain more or less fixed—there being no evidence of any considerable expansion of Andarab's material resources, it follows that the "excess" descendants of the wealthiest men must be impelled to move downward in society (Fig. 2a, paths oa & oc). The sons and heirs of one father know of this necessity, and commonly continue in joint estate for a period. Afterwards, in their longer phase of severalty, one son only, usually the eldest, can emerge with his inheritance augmented (through devices to be examined later) and perhaps attain to his father's position in the world (path oabo); while his father's other sons, his own brothers and half-brothers, remain lesser men or pursue a downward course (path oc...z). The second corollary is that, since Andarab's total population remains virtually constant from one generation to the next,² one might expect to find the "source" of excess balanced by some corresponding "sink" of population (Fig. 2a, point "z").

1 The Koranic law permits a man up to four contemporaneous marriages.

2 See pp. 24-25 above.

In my impression, such is provided by the later age at marriage of poorer youths, and of youths with wealthier fathers but whose older brothers must take precedence over them.¹ It is usually such men who are found residing non-patrilocally in later married life. Widowerhood, for any but a very short period, is also relegated to the poorest grades.²

Andarabis themselves make the point that social mobility occurs in not one but two interrelated dimensions, when they put it that all their quarrels are over either women (zan) or landed property (zamīn). Officials who serve in the district frequently say the same thing. It is only natural that the mutual affairs of Andarabi men should be coloured by **two** sorts of interest in each generation, the apportionment of their primary productive resource (arable land), and of its necessary procreative complement (women). The sum total of the productive resources in arable land, etc., as well as Andarab's total population, remain relatively constant from generation to generation; but the individual fortunes of almost every Andarabi, as property-owner and as pater-familias, are perpetually in flux. The differences among the life-careers of individuals manifest themselves first and foremost in questions of inheritance and marriage,

1 Cf Fig. 1.

2 All this is described with regard to the male portion of society; the female position is somewhat the reverse, from the same causes, tending towards an upward circulation, and more frequent widowhood in the upper grades, etc. (the arrowheads on Fig. 2a needing to be reversed).

or more precisely marriage-making, including the payment of bridewealth.

8. Commercial life

An account of Andarab district cannot be complete without some description of its grain market and two bazaars, although these were barely mentioned among the institutions which contribute to Andarab's coherence as a single municipal borough. The weekly turnover of imported goods and local produce in Banu and Deh Salah, in cash sales and partly by credit, is impressive. The 80 or so Banu shops are open daily and the Banu caravanserai is filled by the tethered horses of those who have business in the district secretariat; but for most Andarabis the market days are every Monday and Thursday, when all the 100 shops at Deh Salah are opened, and the grain market (mandai) also.¹ There is little business done in Banu on these days, while the Deh Salah bazaar is crowded, shop and teahouse (sāmovār) alike. In winter, the popular buzkashi tournament takes place near Deh Salah village on bazaar days, whenever the weather permits. At other seasons,

¹ The Deh Salah bazaar is in the shape of a T-junction, set where the east, west and north routes join (Map 1). It is a few hundred yards from the residential settlements of Deh Salah village, and within easy reach of Saiad and Sangburan.

when the roads and passes are more readily negotiable, the Deh Salah bazaar (with two caravan-serais) is the natural staging post for nomad caravans and others on the road. Thus, apart from being the twin foci of monetized exchanges within the district, both bazaars are also common meeting-places and sources of information, gossip and rumour.

Each bazaar recognizes a headman (kalāntar), chosen aperiodically by arrangement between the shopkeepers and the Town Clerk, on the one hand, and the Deputy Commissioner on the other. The bazaar headmen have duties of liaison mainly.

The bazaars' trade can be divided into, first, the services made available by particular specialists; second, the handling of imported groceries and local agricultural and pastoral produce, including its export; and third, the import and retail of haberdashery, textiles and other manufactured goods. Animals, such as cattle, sheep and horses, are rarely brought for sale to the bazaar; and neither are Andarab's few handicraft products, made from sheep's wool or goat-hair, short-napped coarse carpets, cloaks, blankets, sacking, felt and tentcloth.

The service skills available in the bazaar are those of the baker, butcher, kebāb-griller, teahouse-keeper, caravan-serai man, blacksmith and stove-maker, gunsmith, goldsmith, tailor, and shoemaker, who all sit in shops. Barbers, and the two or three "doctors" (dāktar), practising modern medicine, do not keep premises. Any skilled specialist may be called

khalifa.

There are a number of grocers' shops, dealing in imported long-grained rice, salt, sugar, tea, sweets, matches, kerosene, soap; and local wheat, barley and oats, fresh fruit, dried mulberries, raisins and walnuts. However, the greater part of the trade in local agricultural produce, and clarified butter, some lambs for the slaughter, chicken and eggs, fire-wood and fodder, is carried on directly in the marketplace (mandai) on market days, without shop intermediation. The main exports from Andarab are, in their order of importance, wheat and barley (coarse-grained rice is rarely saleable outside), clarified butter (rōgan), untanned hides and skins, timber (plane and poplar), walnuts, seasonal fresh fruit, and cummin-seed. The export is in the hands of individual entrepreneurs who can afford to buy large quantities, and pay for transportation by the lorry load. They can try to increase their profits by coming to an agreement with producers some months beforehand, as explained below.

The greatest number of shops are those dealing in textiles, items of male clothing, footwear, haberdashery, china, domestic and hardware and utensils, patent medicines, ammunition, writing materials, etc. Virtually all these goods are manufactured abroad, in diverse countries of origin (India, Soviet Union, Japan, eastern and western Europe, China, Iran). Only woollen cloaks (Badakshan), long coats and riding gear (Afghan Turkistan), some footwear and embroidered caps (Kabul),

originate in Afghanistan.¹ These goods come into Andarab from Kabul, Pul-i Khumri or Qunduz, again brought by the lorry load, usually by the same entrepreneurs as are engaged in export.² Apart from the bazaar shop sales, which are their main business, some shopkeepers also supply textiles and haberdashery on credit to the few village hawkers who make extensive rounds to the remoter parts.

According to the amount of capital invested we can thus grade the commercial establishment, disregarding the skilled tradesmen (khalīfa), into (1) the small number of substantial entrepreneurs (sarmāyadār), (2) many middling shopkeepers (dukāndār), and (3) the village hawkers (qawwāl). They all attend the bazaar in one capacity or another. The entrepreneurial Khans are also often moneylenders; in general, the more money a man possesses, the more he can make. In regard to the goods and products a man deals with, there is much variety and overlapping.

A shopkeeper may be a peasant proprietor or a village mullah in addition, and often enough more than one person has an interest in a shop. Such others, a brother, an in-law,

1 Salt, sugar and soap also, in the grocery shops; their kerosene is Soviet and matches Polish.

2 Two lorries which ply the Andarab route are owned by local people (pp. 62-63 above); the others are run by freelance owner-drivers, and call irregularly, making the detour from Doshi. Their regular route is between Qataghan and Kabul.

a Khan, will have provided a greater or lesser part of the running capital, and profits will be shared accordingly. A son, or a younger brother still in joint estate, are paid nothing for keeping shop, while a stranger may get something like a salary; a few shops are merely rented out by the owner, with no further interest. A good proportion of the shopkeepers are immigrants from Panjshir and Kohistan; three Muhammadzai Sardars are shopkeepers in Banu.

In regard to their function, the bazaar shops are essentially comprehensive general stores, a given inventory being determined really by the amount of capital and the time for shop attendance at the owner's disposal. Three-quarters of the Banu shops are kept full-time; while about two-thirds of Deh Salah shops are not. A few shopkeepers go themselves to Kabul for their stores, more than once a year, while others buy from lorry loads brought by arrangement or on speculation by others. Any shopkeeper serves as the intermediary in the distribution of a range of imported goods, the export of local produce, and the internal exchanges. The retail mark-up on regular imports is not great (about 10 per cent, as against considerably more on the odd wireless or wrist watch), but no one carries a large inventory for long, and the entire stock may turn over in a month. A mark-up of 10 per cent and a turnover of six times a year means an annual profit of 60 per cent. It need not be wondered at, therefore, that the prevailing rate of interest on loans is at least 30 per cent

per annum, payable in cash. The earning power of ready money is often greater than this—providing always that one can realise the loan or credit on time.

For example, in May, wheat may be priced in Deh Salah at 22 afghanis per sēr, and in Kabul at 32 afghanis per sēr. For the transport to Kabul, one lorry load is 1,000 sēr, and the freight charge on wheat five afghanis per sēr. Thus someone who could muster a lorry load—as well as a lorry—and make the journey, could reckon on five afghanis per sēr as his profit, or a sum of 5,000 afghanis on the investment of 27,000, within a few days.¹ This latter is a considerable sum to put up in a hurry, and if the entrepreneur could not complete his purchases on market day, he might be obliged to buy an amount at 23 or 24 afghanis per sēr, from some shop-keeper who had purchased it the day before for less. Again, the lorry driver, who is always his own captain, may have different ideas about his itinerary. Nevertheless, this is a simple and straightforward dealing, which does not indebt the entrepreneur's soul to the Almighty through smacking of usury, which the Koran proscribes.

To increase the profit made one must advance credits to several producers some months beforehand, in what amounts to money-lending at high rates of interest. A number of peasant proprietors (more especially those relying on lalmi cultivation)

1 £1 stg = 100 afghanis approx., at the unofficial rate of exchange.

and pastoralists find themselves in straitened circumstances during and just after the winter, having run short of cash for one reason or another. The loan of money to them in say January-April will "purchase" wheat at 10 afghanis per sēr, "delivery" to be taken in August, after the summer harvest, when the Deh Salah market price is around 20 afghanis per sēr. Similarly, wide margins can be claimed against loans made to clarified butter producers and so on.

Money-lending need not be carried on in the bazaar only, nor necessarily in the form of cash. A common form of loan in kind is to give wheat or cloth etc. say in late winter, which has to be repaid some months later, at half the price charged by the lender, i.e. at twice the value. Such loans are called nasiah, "credit transaction", on the paper customarily drawn up between the parties; they often represent an interest rate of 100 per cent in six months. The rate of interest on straight-forward loans may be quoted as 300 afghanis/1,000 afghanis/year (30% p.a.), 30 sēr wheat/1,000 afghanis/year (50-60% p.a.), five sēr wheat/100 afghanis/year (75-100% p.a.), or one half afghani/afghani/six months (100% p.a.); depending upon the nature of the loan and the circumstances of the borrower. The smaller loans carry the higher rates. Capital loans, from an entrepreneurial Khan to a shopkeeper or skilled tradesman with a reliable business, are usually at 30 per cent per annum. If a debt is carried over from one year to the next, the simple interest must be paid

every year; most loans are paid off within one or two years. The creditor-debtor relationship occurs both within the village and outside it; but it does not occur (preferably) among close relatives.

The last form of borrowing to be mentioned is by the mortgage or pledge of land (girau). In this case, the debtor continues to work the pledged plots, and the pledgee takes half or even all their produce until the debt is repaid with simple interest. Well-to-do men, or after them their sons, have to borrow and pledge land on occasion in this way. Only poorer people in reduced circumstances seek nasiah loans in kind.

It is difficult to judge to what extent the earning power of money itself is emancipated (if at all) from the overriding power of land. Those who engage in commercial dealing often begin as land-holders in addition, and eventually look to buy more land with their accumulated earnings. The pastoralist's routine is too demanding throughout the year for him to show much inclination for shopkeeping.

CHAPTER III

THE FIELD SITUATION

I have thus far described the situation, setting and elements of social organization of Andarab as they might be described by an investigator who had never visited the valley, but had assiduously gathered information from Andarabi natives in, say, Kabul. (The earliest monograph on Afghanistan, and still the finest and most extensive, was in fact compiled and written by an Englishman who never set foot in the country, but worked in Peshawar.¹) In this chapter, I describe my method of fieldwork, looking back on the foregoing account of Andarab as a whole, and with the object of looking forward to the more analytical themes to be dealt with in the succeeding chapters. The present section is necessary to explain the circumstances in situ, which influenced the selection of the topics presented hereafter.

1 Mountstuart Elphinstone, An Account of the Kingdom of Caubul, and its Dependencies in Persia, Tartary and India: Comprising a View of the Afghaun Nation, and a History of the Dooraunee Monarchy (London, 1815).

1. Method of fieldwork

I spent two and a half years in Afghanistan, in 1959-1961. I first visited Andarab, as part of a wider reconnaissance of the central Hindu Kush, in July 1959, and resided in the district for periods of varying duration, seventeen months in all, until August 1961. The remainder of my time was spent mainly in Kabul. In all this period, I enjoyed no sure security of tenure, either in the country or in the field, and it was owing more to the inefficiency of the administration, and my own inertia, rather than to the government's goodwill that my project was carried out. I am happy to say that at the time of writing, the new developments foreshadowed by the new Constitution (September 1964), augur rather better for future investigators. In my time it was still forbidding—if not actually forbidden—to contemplate social research in that little-known and richly rewarding country.¹

I did indeed obtain the necessary premits, after the requisite expenditure of effort and energy in Kabul, but the local authorities interpreted these narrowly and restrictively,

1 Cf H. F. Schurmann, The Mongols of Afghanistan (The Hague, 1962), p. 180: "Afghanistan is still somewhat inaccessible to ethnographers who desire to remain for a protracted period of time in some spot in the interior in order to make detailed observations on a small number of communities."

according to their own lights, being little inclined to give credence to the object of my mission or to allow me the scope to proceed freely. Afghan officials in Kabul and more especially in the provinces were accustomed to view the activities of all foreigners with suspicion, particularly in out of the way places. They generally classed sociological investigation with intelligence work and political interference, and their evidence for this connection was sound, if a little out of date.¹ The matter was not improved if one turned round and expressed a wish to study local administration: this could only mean superior and damaging reportage of malversation.

The populace, on its side, was naturally averse to continued association, officially unwitnessed, with someone who was a marked man in the eyes of their government; it could be made an indictable offence.² In any case, all who befriended me and made me their guest, knew full well that they would be held to punishment or ransom if any ill should befall me whilst in their company or neighbourhood. I was obliged to abandon following up many an informant for this reason alone.

I offer the following episodes as examples: one deputy commissioner, herein referred to as HAKIM X, once expressly

1 An officer of the British army and intelligence, subsequently knighted, was the author of the only ethnographic monograph based on protracted residence: George S. Robertson, The Kafirs of the Hindu Kush (London, 1896).

2 In Kabul itself I twice hired manservants who absconded rather than accompany me to the field; one man even leaving me with his identity papers. The Andarabis, too, detest to work for wages; and I had eventually to settle for an

forbade me to visit my best companion's village, and he relieved another of my informants of 500 afghanis (£5) as a mulct; during the period of a second deputy commissioner, HAKIM XI, who was himself an educated man, a third informant was similarly summoned and warned by the local COMMANDANT OF GENDARMERIE; the COMMISSIONER of Pul-i Khumri division summoned myself by special messenger to answer the charge of having surreptitiously set up as a doctor; while the COMMANDANT OF GENDARMERIE of Qataghan province, who had previously given me his own manuscript visa on my passport, wrote from Baghlan to HAKIM XI that I was to be kept under observation and forbidden to go out shooting; the same official in Baghlan finally informed the central Kabul authorities that I was conducting myself during the 1961 general election (in Andarab) in a manner "contrary to the dignity of the state". Thus the bureaucratic right hand did not always understand and honour the official permits which the left hand had (knowingly or unknowingly) granted me.

Equally important was another social fact, that local officials and people alike were Muslims, proud of their orthodoxy, to whom it was a constant reproach to associate with an idolatrous "Hindu" - or Sikh - like myself. The ubiquitous mullahs' traditional teaching naturally made them contemptuous and fearful of such contact. In this regard I could have gone

"orphan" of Sangburan, of Panjshiri origin, whose step-father was in the employ of the Pul-i Khumri Textile Company's foreigners' club.

to Afghanistan better prepared—short of a genuine conversion to the great fraternity of Islam—if I had obtained the time to become familiarized with the written corpus of shari'at, and its many detailed regulations, instead of with the Koran merely.¹ Andarabis, exemplary Muslims that they are, attempt to follow the traditional shari'at code in all departments of their life; local usage and custom (rawā'ij) depart from it only in non-essential, minor points, so that I created only embarrassed disbelief when I first expressed a studious interest in "local custom".

Andarabis showed an ineradicable conviction, moreover, that, if there was anything to be justifiably sought in their wild mountains rather than in say Kabul, it must be geological or archaeological; and I never disabused the generality of labelling me among themselves as that "Hindu who searches for treasure". They were certainly right in their view, in the sense that the only foreigners to visit the valley during my stay were geological prospectors from the French Commissariat l'Energie Atomique, surveying the Hindu Kush for uranium ore, on behalf of the Afghan Ministry of Mines; and my own subsequent (literary) search revealed that Andarab does indeed

1 I could not remedy this deficiency during any of my periods of enforced leisure in Kabul, since that city did not possess any adequate library. I should have taken with me to the field T. P. Hughes' Dictionary of Islam (London, 1885), rather than an English Koran.

possess many excavable archaeological riches of the Muslim and pre-Muslim eras.¹

I was in Andarab not only as a foreigner (khāriji) and an infidel (kāfir), but also as a single man—and I have already described how jealously the Andarabis seclude their women, and guard their domestic privacy. On each of these three counts, therefore, I was unwelcome to attach myself for long to any particular local group, so as to become privy to its innermost life. I did what I could, and what I had to, in order to learn whatever is here presented, within these combined limitations.

I set up house at a neutral and much frequented point, the central commercial bazaar of Deh Salah,² which was as far from the Banu secretariat as the Deputy Commissioner

1 "That Andarab (Ariaspa) held the capital of the Greek colonies there can be as little doubt as that Haibak and its neighbourhood formed the great Buddhist centre between Balkh and Kabul. Again, who is going to make friends with the Amir of Afghanistan and try his luck? It must be a foreigner, for no Englishman would be permitted by his own government to pass that way at present" (Sir Thomas Holdich, The Gates of India (London, 1910), p. 511).

According to Codrington, coins were struck in Andarab successively by the Abbasids, Samanids, and Ghaznavids, in roughly the ninth, tenth and eleventh centuries A.D., respectively: see V. Minorsky, trans., Hudūd al-Ālam (London, 1937), pp. 109, 341.

2 I fitted out the upstairs rooms (bālākhānā) above some shops, which had independent access and were the only construction in the bazaar above the ground-floor level; they were useless to shopkeepers and their three part-owners had allowed them to fall into disrepair, after having nominally made them over to their Town Clerk. It corresponded very much to a residence overlooking, say, Canberra's Civic Centre—except in the particular that the three owner Khans never accepted any rent from me.

would allow me to go. I attempted there to make myself seem agreeable, complimentary, or at any rate passively innocuous, to comers of all shades. The fact that my visitors called openly, and within the common knowledge, paradoxically achieved for our conversations such security and privacy as were possible—though not, of course, without laying my callers' reputations open to the tarnishing reach of interested or idle slander. I gradually found myself, after acquiring some proficiency in spoken Persian, dividing my time between receiving visitors, especially on the Deh Salah market days, and guesting with friendly people in many different villages, for varying periods of time. I travelled incessantly at all seasons, preferably with company, upon any pretext, visiting and staying everywhere within Andarab where I was made welcome. I found the well-to-do to be more unafraid in this, and even the religious establishment could be suitably flattered to both receive and visit me. I established relations of mutual intervisitation with each Deputy Commissioner,¹ and always found my sojourns in the Banu secretariat instructive, even if I was never permitted to attend the Qazi's court. The Deh Salah commercial establishment, who profited most from my

1 The deputy commissioners, like some other officers, customarily have their conjugal families living with them during their period of posting. The households and dwelling-house of HAKIM X and his successor HAKIM XI were the only ones to which I had access during my period in Andarab.

presence, generally shed no tears on the day that I had to leave the field, for our mutual relations were usually impersonal. But among some others in Andarab the "sorrow of parting" was sincere—as it certainly was on my side; and I counted my fieldwork fulfilled.¹

I have made it clear that I followed the methods of fieldwork associated with studies in social anthropology in all respects except in the essential and central one, that is (1) I did not confine myself to one particular local group, whose affairs in all social departments a single investigator could study and note down within the period of a year or two; and (2) it never availed me to train any systematic informants. I most often learnt one thing about one village, and a different thing about quite another village; and the same with individuals. My method (or lack of it) was to first secure a general acquaintance with the entire culture of Andarab district, and then to pursue my enquiries successively in one direction after another, so as to leave no strategic direction unexplored. This is the method (of course) natural to the sociologist who is investigating a complex civilization, but I had not the

1 I mention here that the Kabul government was particularly sensitive to any foreigner's presence during late 1960, when armed hostilities with Pakistan broke out on the eastern frontier, and it was a major step to have a stay visa renewed (though Indian nationality was an advantage). A year later, in September 1961, just after I left the country, diplomatic relations between Afghanistan and Pakistan were ruptured, and the frontier closed for a further two years, until 1963.

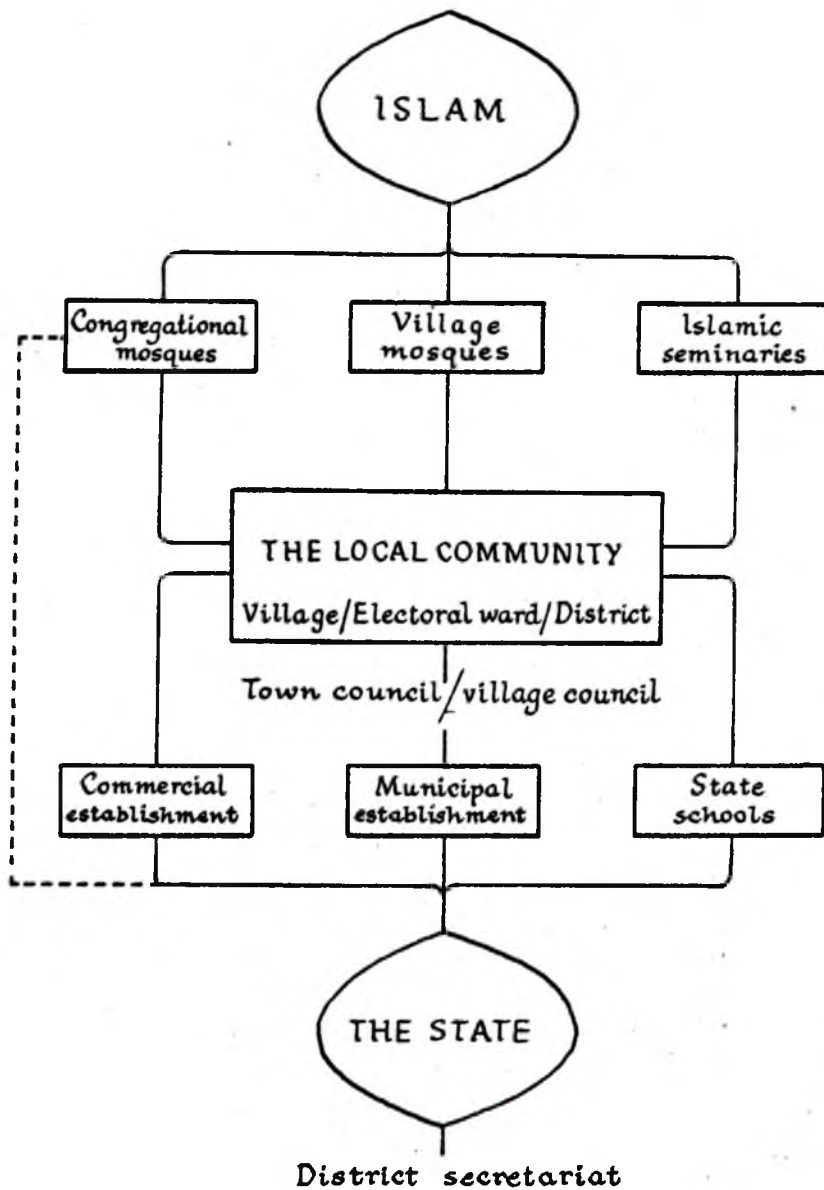

Fig. 3 Andarabi social organization

wherewithal to conduct the most elementary social survey soundly; my methods were indirect, piecemeal and episodic.

2. Categories of social structure

"Social structure is not an aspect of culture but the entire culture of a given people handled in a special frame of theory." - M. Fortes

The reader will know from the general account in Chapter II what is here meant by social organization. I refer by this term to the prima facie, institutionalized arrangement of persons and customary activities, such as might be described by an imaginary, articulate informant. In this sense, the social organization of Andarab may be conveniently summarized in diagrammatic form, as in Figure 3. To speak of "social structure", on the other hand, is to regard the categories of social action at a more abstract level, and to discuss their interrelations as problems within "a special frame of theory". The three main categories of institutionalized social action in Andarab are the local community, Islam, and the state. I have already explained that socio-economic stratification, on the basis of wealth, occupation and income, does not possess an articulating role within the social structure; and commercial dealings also, for the reasons given in the foregoing chapter (section 8), remain to a great extent integrated within the local community.

I first became aware of the three great divisions of society as the contributing elements which determined my own situation in the field. It was early borne in upon me that I was not a member of three social systems which intersect within Andarab: firstly, the local community, with its patrilocalized kinship and in-marriage; secondly, the inclusive and cosmopolitan society of the Islamic fraternity; and, thirdly, the official community of the Afghan state. As the stranger to all of them I was naturally allocated the one point of neutral observation and marginal participation, the central marketplace, situated away from and outside the walls of the village homesteads, the congregational mosques and the secretariat. I now emphasize further that there are no social situations, or series of situations, occurring within Andarab, which can be understood without making reference to the same three fundamental elements of the "entire culture". They form the constant framework of all departments of social life; and the nature of Andarabi society, at any period of its existence, can be resolved in terms of their combined presence and mutual interrelations. In succeeding chapters we shall be concerned to explore each of them further, as far as my material and present understanding of it allow.

In Chapter IV we view the local community as a political group of co-resident mutual supporters and allies, as well as competitors; and investigate its underlying pattern of residence, inheritance, and marriage, in relation to the

individual's domestic cycle. Since Andarabi society contains no fixed, enduring statuses, or corporate groups which seek to maintain a joint estate in perpetuity, it will be preferable to speak of "inheritance" rather than of "succession". In Chapter V we examine the system of government, regarding it as including the business of administration as well as local politics, and taking the intercalary position of the Deputy Commissioner as illustrative of the Afghan state's working. In Chapter VI we examine the conception of Muslimhood interpreted by Andarab's religious establishment, with special reference to the ritual customs followed by the local community as a Muslim congregation.

It seems desirable to add that I was not the only person in Andarab to be conscious of the conception of social structure quoted at the beginning of the present section. The local legists, the Andarabi mullahs, were also occupied in handling "the entire culture" "in a special frame of theory"—the special theory of the Muslim community, the umma of Muhammad the Prophet, who finally revealed the way, complete in all respects. I do not propose, however, to follow where the legists lead—as an Islamist would—and "endeavour to investigate the effects of the religious system of Islam on the life and organization of the societies which acknowledge it".¹ I have already followed the mullahs

1 Reuben Levy, The Social Structure of Islam (Cambridge, 1957), p. v.

inasmuch as they distinguish among (1) themselves, as the guides, (2) the people (mardum), their parishioners, and (3) the government (hukūmat). After this point I write in Chapter VI as a social anthropologist would, and not as one proficient in Islamic studies.

CHAPTER IV

FAMILY, KINSHIP AND COMMUNITY

1. Introduction*

The domestic household, the family group of parents and children, is the central pivot of Andarabi society. It is founded upon (a) the conjugal relationship, established by marriage, and (b) the filial relationship, established by birth. Where there is more than one wife, the head of the polygynous household is a kind of multiple paterfamilias. The co-wives are jealous of their parity; they take turns to cook at the common hearth, and sleep, each with her own children, in separate rooms. People can foretell that surviving sons with different mothers are less likely to continue jointly managing their father's estate, than are sons born of the same mother. Nevertheless, the larger the size of the household, the greater the scope of the paterfamilias' authority, and the more lasting, even after his death. For, most likely, he will leave behind a

* Additional to the remarks on pp. 27, 29-39: multiple marriage rates, 27; household size and structure, 29-32; patrilineal framework, 33-35; household structure and the status of women, 35-37; local group composition, residence and in-marriage rates, 37-39.

widow, a late married wife, with young children, as well as the older son or sons, already householders in their own right. In this phase, the sons characteristically separate themselves slowly. They will know their own shares of the arable land, for example, and may exploit it severally, but with some joint management also, under the headship of the eldest brother, until events can clarify the position of their father's widow and unmarried children, their paternal half-siblings and co-heirs. The monetary income and the arable are the first to come under division, often within the father's lifetime, while marginal real estate (the homestead compound, an orchard, a piece of lowland pasture) may continue physically unpartitioned for generations, only its use or produce being divided. Coparceners possess legal rights of first purchase (pre-emption) if inherited property is to be sold.

Outside the domestic household (khānā) the Andarabi reckoning of "my people" is done according to two conceptions, which are distinct but interrelated. The first is the qaum, Ego's local community, at whatever level, and the second is the kh'ēsh, referring to Ego's particular relatives, kinsfolk. The qaum is the body politic, invariably, territorial and localized, predominantly male, and, in its smallest segments, reckoned within the patrilineal framework. The kh'ēsh are Ego's own relatives, kinsmen as well as kinswomen, reckoned patrilaterally (rather than patrilineally), matrilaterally,

and affinally. It is the category of kin relations reckoned with regard to marriage prohibitions, above all else. It is not generally a localized group and, since Ego cannot marry anyone included within it at a given time, one's kh'ēsh are these particular persons who alone may as well as should concern themselves with the domestic affairs of one's conjugal family. By virtue of such recognized links of kinship (kh'ēshi), each individual person has reciprocal access to the domestic domains of a specified number of other persons—and of these few only. ✓

The individual enters into the social world identified first with his or her father's household, and secondly with the co-resident group of near collateral agnates, the cluster of Ego's brothers and paternal half-brothers, paternal uncles, and so on. This is Ego's own intimate patrilineal segment of the local community throughout life, a parish within the parish. The nearest older agnate acquires legal guardianship and authority over Ego in the event of Ego's father's (and father's father's) death. The collateral agnates are the coparceners with Ego by patrification at one or more removes. Ego's particular individual relationships with them in later life depend primarily upon what marital alliances are made within the cluster or outside it, through Ego's own marriage(s) or through those of his or her siblings and own children. In every succeeding generation, one or more marriages are customarily devoted to keeping the cluster close-knit, while others

serve to establish alliances outside, on an individual basis. The Koranic law recommends the allying together of two brothers through the bestowal of the daughter of one on the son of the second, who possesses pre-emptive right of claim in this matter as in the sale of inherited property.

The primacy of the household unit intrudes upon the Andarabi reckoning of kinship at every point; wider kinship links determine very little in their own right. A boy or single youth can attend school or venture away from Andarab, e.g. on conscriptive service with the Army, only if the paterfamilias, the father or older brother, can spare him. A married man can engage in an occupation which takes him away from home for longish periods, either within or outside Andarab, e.g. village headmanship, only if his conjugal family can continue to function in honourable privacy without him, in care of his father, brother, son, or, rarely, daughter's husband, etc. A householder who has no agnatic kinsman within the prohibited degrees of marriage from the point of view of sister or daughter, his wife, is excused national service officially. Speaking conversely, in some phase of his life, a man may be reduced to dependence in some form upon a kinsman better placed than himself, say a land-holder whose resource of male labour is short; and the latter will usually be some relation through marriage, rather than an agnate. A youth or older married man may be engaged in working for his sister's husband or wife's brother, wife's father or even daughter's husband, sister's

son, wife's sister's husband.¹ The former (incomer) will be reckoned as part of the latter's domestic household as a hamsāyā, ~~1900-~~ **co-resident** dependent neighbour. Agnatic collaterals are wary of involvement with one another in this way—as also of mutual indebtedness—because they are mutual heirs in law, and wish to avoid possible complications. Two brothers in severalty will still help one another, and may employ a single peasant labourer (dehqān) for their fields, whose produce they divide equally; but the partitioning walls between ex-coparceners generally tend to harden with the passage of time. One who finds himself in a marginal situation, and with an inherited share hardly viable in independence, may be forced to sell it to a brother or other coparcener, and depart the patrimonial homestead to become someone else's hamsāyā, as just explained.

The contrast between agnatic and non-agnatic kinship is the contrast between those bonds among men which are created through coparcenery, and controlled by the system of inheritance, as against those bonds which are created through marriage and the payment of bridewealth. By definition the relations among the sons of one father belong to the first category, but

1 A woman is not in purdah from her sister's husband since a man is forbidden to marry two sisters contemporaneously. For the special relationship between the husbands of two sisters see pp. 106, 118 below.

TABLE 2

First cousin marriage rates

Saiad village

N = 107 extant marriages*

Type of relationship:	Frequency per cent:
1. Father's brother's daughter	12
(1a) Brother's widow / Father's brother's widow	3
2. Mother's brother's daughter	3
3. Father's sister's daughter	1
4. Mother's sister's daughter	-
	19
5. Others (more distantly related or unrelated)	81
	<u>100</u>

*Excluding n = 16 marriages (not known) where both spouses immigrants to Saiad: total extant marriages (N+n) = 123.

the relations between a brother and a sister, or between two sisters, which carry no weight of inheritance, are more properly classed with the conjugal tie. Along with it they belong to the category of what might be called personal kinship. During his lifetime the individual reckons his relatives and allies equally as much through personal kinship as through agnatic kinship, but the main ~~sub~~ legacy which survives his death lies with the latter reckoning rather than the former. The pattern of marriage in the succeeding generation is an authenticating sign of this contention.

Classifying marriages on the strength of the prior genealogical relationship between the parties alone, and confining ourselves to first cousin marriages, we have the markedly different frequencies indicated in Table 2, taken from a count in Saiad village. The cypher rate in the fourth row (mother's sister's daughter) means only that no male householder residing in Saiad at the time of the count was married to his matrilateral parallel cousin. One year before, a man of Saiad village had in fact gone to Kabul and married his mother's sister's daughter there. With regard to the important factor of residence, all the 12 per cent patrilateral parallel cousin marriages had been made between parties with prior domicile within the village, or indeed within the same village section (10 per cent). Matrilateral cross-cousin marriages ($n = 3$), by way of contrast, showed no such consistency; in one case, the spouses had belonged to the same village section;

in the second case, to the same village; while in the third case the girl had belonged to a different village. Included within the 81 per cent other extant marriages are some with remoter cousins of different kinds, but the greater majority of marriages are made between persons not directly related. (Among the remoter cousins' marriages was one with a FBSD and one to a FFBDD of the same village section; one to a FMRD of another village; and one to a FFBSD of a town outside Andarab district.)

The real socially relevant distinction, however, does not lie among these different categories, but between what might be termed parochial marriage versus extra-parochial marriage. Marriage with the father's brother's daughter, the brother's widow or the father's brother's widow, is the type of the parochial marriage (15 per cent of all cases). It looks within rather than without the smallest local group, the agnatic cluster; it acts to develop prior bonds rather than to strike out fresh ones—and is therefore characterized by the least festivities and bridewealth; and it comes closest of all Andarabi marriages to being negotiated straightforwardly, without clamour and upset from rival claimants and other would-be suitors. In contrast to it even matrilateral cross-cousin marriage appears an ambitious undertaking, competitive, and concerned with becoming well-connected in the world, as will be apparent from the illustrative case in section 5. Parochial versus extra-parochial is of course a relative contrast, and

I make it advisedly. The genealogical form of a marriage is merely the first clue to its meaning, which can be filled in only by taking into account also the relative socio-economic and demographic standing of the bestower and the bestowee, their domicile, and their other alliances, direct or indirect, accomplished or intended. The touchstone which can unfailingly reveal the true social circumstances of the case is to consider who else—besides the bestower and the bestowee, the giver and the receiver of bridewealth—was involved in the antecedent story of the match, and in what capacity. The cardinal points of reference of every marriage are: (1) the developmental cycle of the domestic household, and (2) the configuration of alignments within the local community, including particularly the individual's agnatic cluster; section 5 analyses a particular marriage in these terms.

2. Inheritance and marriage rules

"Allah has thus enjoined you concerning your children: A male shall inherit twice as much as a female. If there be more than two girls, they shall have two-thirds of the inheritance; but if there be one only, she shall inherit the half. Parents shall inherit a sixth each, if the deceased have a child; but if he leave no children and his parents be his heirs, his mother shall have a third. If he have two brothers, his mother shall have a sixth after payment of his debts and any legacies he may have bequeathed."

— Koran, iv: 12

The law of inheritance (mīrās) is acknowledged to be an intricate and difficult object of study, even by the Muslim doctors and legists. Its salient characteristics are that, first, it is a system of partible inheritance par excellence; second, it weighs heavily in favour of the direct line of patrilineal descent; and, third, it prefers males over females. Moreover, "when a deceased Mussulman leaves behind him two relations, one of whom is connected with him through the other, the former shall not succeed whilst the intermediate person is alive. For example, if a person on his death leave behind him a son and that son's son, this latter will not succeed to his grandfather's estate while his father is alive."¹ In all these regards, Andarabis adhere to the orthodox law, and I must briefly quote two authorities upon it.

"The property of a deceased Muslim is applicable, in the first place, to the payment of his funeral expenses; secondly, to the discharge of his debts; and, thirdly, to the payment of legacies as far as one-third of the residue. The remaining two-thirds, with so much of the third as is not absorbed by legacies, are the patrimony of the heirs.... Among these the first are persons for whom the [Koranic] law has provided certain specific shares or portions, and who are thence nominated Sharers, or zawū 'l-furūz. In most cases there must be a residue after the sharers have been satisfied; and this

1 S. Ameer Ali, Personal Law of the Muhammadans (Calcutta, 1880), p. 41.

passes to another class of persons who from that circumstance may be termed Residuaries, or 'asabah [agnates]. It can seldom happen that the deceased should have no individual connected with him who would fall under these two classes; but to guard against this possible contingency, the law has provided another class of persons, who, though many of them may be nearly related to the deceased, by reason of their remote position with respect to the inheritance, have been denominated Distant kindred, or zawū 'l-arhām."¹

I quote a second authority to explain and put in perspective the relative claims of the different classes of heirs. He is explaining the principles of the Hanafi school, which is the established "rite" of Andarab, and Afghanistan as a whole:²

"The principles of the pre-Islamic customary law may be summarized as follows: (1) The nearest male agnate or agnates ('asabāt) succeeded. (2) Females and cognates were excluded. (3) Descendants were preferred to ascendants, and ascendants to collaterals. (4) Where the agnates were equally distant, the estate was divided per capita. These principles should be borne in mind; for it will be found that ... the Hanafi law, to a certain extent, retains the principles of ancient tribal law. The main reforms introduced by Islam may be briefly stated as follows: (1) The husband or wife was made an heir. (2) Females and cognates were made competent to

1 T. P. Hughes, Dictionary of Islam (London, 1885), p. 207.

2 See Chapter I, p. 5.

inherit. (3) Parents and ascendants were given the right to inherit even when there were male descendants. (4) As a general rule, a female was given one half the share of a male.

" ... There are two sets of persons who inherit: (i) the primary heirs, who are never excluded, they are the husband or the wife, the father and the mother, the son and the daughter [i.e. the spouse, the parents and the children]; these heirs exclude others on occasion, but are themselves never excluded; (ii) all the other heirs, each of whom may be excluded by someone else. For example, the brother is an heir [a collateral]; but he may be excluded either by the son [a descendant] or by the father [an ascendant]."

Finally, in explication of the lion's share going to the agnates—technically called Residuaries ('asabah)—as against those termed Sharers (Koranic heirs, zawū 'l-furūz):

"For instance, a man dies leaving a widow and a son. The widow is a Koranic Heir and she gets 1/8 of the estate, while the son, a tribal heir ['asabah], takes the remaining 7/8. This is an illuminating example of how Koranic reform affected Arabian custom."¹ If there had been more than one wife, the widows' combined share would be the same one-eighth.

The principal practical rule of inheritance in Andarab is the equal division of the patrimonial estate among all the sons. The question of the father inheriting from the son does not normally arise, since the estate is rarely partitioned before the father's death. The widow(s) one-eighth share, while it

1 A. A. A. Fyzee, Outlines of Muhammadan Law (Oxford, 1949), pp. 333-334, 336, 340.

may be nominally computed on the occasion of partition among the sons, is understood to consist in her life's maintenance by the successors (the own sons or husband's sons), with whom she continues normally to reside. A widow within the reproductive age, or with custody of young children, is often remarried to the husband's brother, or brother's son (with the concurrence of her own father or brother).¹ If none such exists, or if she or her marriage guardian are not agreeable, she may marry someone else, but even this will not affect her previous children's inheritance. Similarly, the daughters' legal half-shares are commonly assumed to have been made over by them to their brothers (or father's sons), as the law makes provision for them to. If a daughter were to inherit landed property, for example, she would in any case have to make it over to her husband for management. A man can, indeed, hold it over his wife's brother that the latter's sister wishes for her legal share, and the matter could be taken to court. It would be more an expression of bad blood between the two men, however, than the means for the daughter to come into an inheritance. Women cannot hold any important property as a rule, except their jewellery and personal effects; these are passed down to their daughters.² At the same time, a

1 "Believers, it is unlawful for you to inherit the women of your deceased kinsmen against their will, or to bar them from remarrying, in order that you may force them to give up a part of what you have given them, unless they be guilty of a proven crime" (Koran, iv : 24).

2 Fathers often send a new-born calf, etc. to their young married daughters; such gifts are the girl's personal property. See also p. 37 above.

man should seek good relations with his sister, for the molli-
fication of her dormant claim upon his patrimony (equivalent
to the claim of half a brother), if for no other reason.

I may instance here (from Rashidi village) the case of
the childless widow whose Koranic entitlement was computed at
one-quarter of the estate (as against one eighth if she had
had children), the "remaining" three-quarters going to the
deceased's brother. In fact, the latter, through marrying
the widow, in effect re-amalgamated with his own inheritance
that which his brother had formerly partitioned from him.
According to both law and custom, this was right and proper.

In general terms, I should say that Andarabis obey
faithfully the spirit as well as the letter of the law. To
make matters official the village mullah can be summoned to
determine the successors' portions. Andarabis accept the
implications of the system of partible inheritance, and do
not strain at it. It is true that the female heirs do not
in fact come into their appointed portions, but even this
customary anti-feminism cannot be declared to be inconsistent
with the general status of women enjoined by Islam. The law,
in any case, does not specify in what form the shares of the
various successors are to be realised.

Turning now to the marriage rules, we must refer again
to the Koranic regulations first. The prohibited degrees are

there laid down as follows:

"Henceforth you shall not marry the women who were married to your fathers. That was an evil practice, indecent and abominable.

"You are forbidden to take in marriage your mothers, your daughters, your sisters, your paternal and maternal aunts, the daughters of your brothers and sisters, your foster-mothers, your foster sisters, the mothers of your wives, your step-daughters who are in your charge, born of the wives with whom you have lain (it is no offence for you to marry your step-daughters if you have not consummated your marriage with their mothers), and the wives of your own begotten sons. Henceforth you are also forbidden to take in marriage two sisters at one and the same time. Allah is forgiving and merciful" (Koran, iv : 26, 27).

The succeeding verse defines the payment of mahr (dower), which is construed in Andarab as coinciding with bridewealth, payable to the woman's marriage guardian:¹

"You are also forbidden to take in marriage married women, except captives whom you own as slaves. Such is the decree of Allah. All women other than these are lawful to you, provided you seek them with your wealth in modest conduct, not in fornication. Give them their mahr for the enjoyment

1 Wali: see p. 34 above. He (the father, older brother, or other close agnate) is also the proper person, at her death, to wash the body and lead the burial.

you have had of them as a duty; but it shall be no offence for you to make any other agreement among yourselves after you have fulfilled your duty. Allah is wise and all-knowing" (Koran, iv : 28).

On the exegetical meaning of mahr, I quote that: "Dower is considered by some lawyers to be an effect of the marriage contract, imposed on the husband by the law as a mark of respect for the subject of the contract—the wife; while others consider that it is in exchange for the usufruct of the wife, and its payment is necessary, as upon the provision of a support to the wife depends the permanency of the matrimonial connection.... The dower need not invariably be in currency, or even in metal; everything, except carrion, blood, wine, and hog. Also the bridegroom's own labour, if he is a free man, being held by the law to be a good dower.

"Dower is generally divided into two parts, termed mu'ajjal, "prompt," and mu'ajjal, "deferred".... The custom of fixing heavy dowers, generally beyond the husband's means, especially in India, seems to be based upon the intention of checking the husband from ill-treating his wife, and... also from wrongfully or causelessly divorcing [her]."¹

All this applies to Andarabi custom, if we substitute bridewealth (qālīn) for dower (mahr). The distinction between

1 T. P. Hughes, Dictionary of Islam (London, 1885), p. 91.

"prompt" and "deferred" mahr is not generally made, although fictitiously large sums may be entered under both headings on the official certificate, in the minority of cases where such is obtained from the Qazi's court. Andarabis are customarily very reluctant to part with their daughters, and payments of bridewealth must be completed before the date of marriage. The feasts given at the bride's place and the groom's place are both chargeable to the suitor's expense; and he is very little compensated for his total outlay by the small dowry of household goods customarily sent with the bride. The main significance of the bridewealth is as the material consideration paid to the marriage guardian for the transfer of his rights over his ward to her future husband. Along with the marriage celebrations, it marks her emergence from in statu pupillari to the conjugal state. The marriage rite itself is little developed in Islam. The bridewealth can be returned only in the abnormal event of divorce being pronounced (by the husband only, in Islam) within a relatively short period, and upon a childless woman.¹

1 Custody of children (boys until seven years old, girls until puberty and commitment to marriage) rests with the mother in all cases, so that divorcees are either childless women or older women with grown and married issue. The same is usually true of widows who remarry outside, i.e. as against being inherited by the deceased husband's brother or brother's son.

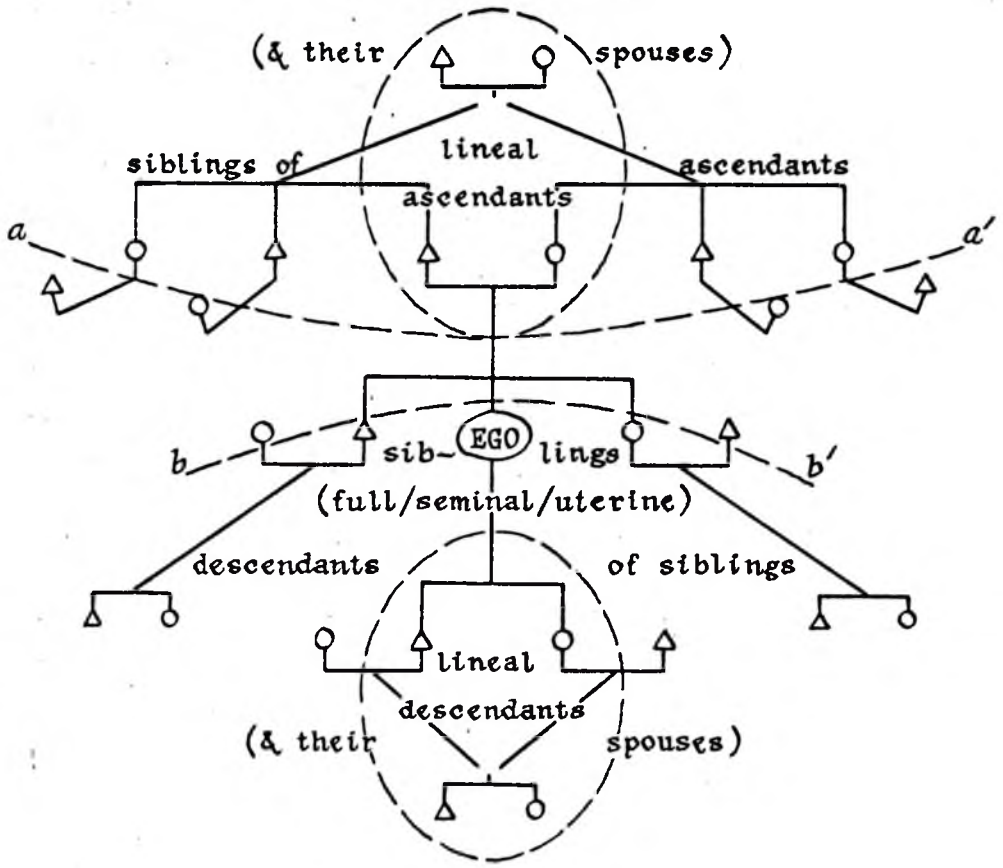

Fig. 4 Marriage prohibitions

If the lately-wed wife should happen to die not long afterwards, a marriage of replacement may occur with her sister, without the payment of further bridewealth, though the girls' father cannot be compelled to the second match. Furthermore, only through such a second marriage can two sisters come to be counted (successively) among the wives of one man: the Koran expressly forbids the taking of two sisters "at one and the same time", and a man cannot in practice divorce one sister and nevertheless expect to marry the second. With this point in mind we may look again at the prohibited degrees quoted from the Koran.

First, there are the "absolute" prohibitions, independent of time and circumstance. No marriage of the male or female Ego can ever occur with the lineal ascendants and their spouses, or the lineal descendants and their spouses (the two circles shown in Fig. 4); with the siblings of the ascendants (Fig. 4, line aa'); with Ego's own siblings, whether full, seminal or uterine, nor with the siblings' descendants (Fig. 4, line bb'). Further absolute prohibitions, flowing from Ego's own marriage(s), are with the spouse's lineal ascendants and lineal descendants.

The second category is of "relative" prohibitions, which forbid certain marriages to occur contemporaneously, but allow them in succession. These are marriages with the spouses of Ego's near collaterals, i.e. siblings and ascendants' siblings (persons on the outer edges of lines aa' and bb' in Fig. 4),

and, conversely, with Ego's spouse's near collaterals. Since, at any given period, the female Ego can be married to one husband only, while the male Ego can have up to four wives, the prohibitions on contemporaneous marriages are of wider implication to a man than to a woman. Nevertheless, it is sociologically appropriate to state the "relative" prohibited degrees independently of Ego's sex, to emphasize that the marriages which do occur in practice in this category are very similar from the male or female points of view. A man may marry his deceased wife's sister, as just explained, or a woman her deceased husband's brother (or brother's son); in either case, the succeeding marriage serves primarily to continue the first, adducing the deceased spouse's closest collateral as the successor.

The Muslim legists say, from the man's point of view, "All the schools prohibit contemporaneous marriages with two women so related to each other that, supposing either of them to be a male a marriage between them would be illegal,"¹ That is, a married man cannot, while the conjugal bond holds, marry any relative of his wife whom she could not herself marry if she were a man—a way of expression which clearly shows an identity between husband and wife, for this purpose, as if they were brother and sister.

In all, a man acquires upon marriage a second set of female relatives, additional to the set acquired by birth,

1 Hughes, *op. cit.*, p. 317.

who are not in purdah from him because they are prohibited in marriage; and the second set is of the same extent, reckoned in exactly the same way, as the first. The same is true also from the female point of view. A man must avoid even the sight of all other women and girls; all females over ten years old are rigidly secluded from the general gaze, and may have aught to do only with those whom they cannot marry—a system which is the exact inverse of systems of selective avoidance between the sexes. In Islam, a man does not avoid his wife's mother or son's wife, ever; he must avoid his wife's sister (and she him) immediately his wife dies, for he is then free to marry her.

The same prohibited degrees, laid down by the Koran, which define negatively the limits of purdah in Andarab, also define positively the general limits of personal kinship (kh'ēshi), and define them identically for an individual of either sex. The important point about these limits is that they are established equally as much through marriage, the individual's own or someone else's, as through birth and the reckoning of filiation, either through the father or the mother; the conjugal link being fully assimilated with the reckoning of bilateral descent to produce the total pattern of kin relations. (In diagrammatic form, Fig. 4 should be read as relating to an Ego of either sex, as well as to Ego's spouse, to give the total reckoning.) I stress again that this pattern of personal kinship is in complete contrast to

the reckoning for the purposes of inheritance, which is rigidly agnatic and exclusively male in practice.

I should like now to explain certain patterns of marriage occurring in Andarab, which are different from those of certain other Muslim peoples in Afghanistan and elsewhere. All who live by Islamic law must follow the same general rules and recommendations, but the variations found within these limits are revealing too. Andarabis adhere to the Koranic marriage prohibitions in the manner above described, and even their quoted rate of patrilateral parallel cousin marriage (pp. 95-96) can be regarded as a general characteristic of orthodox Muslims everywhere. Where they differ from the Afghans, for example, is that in Andarab it is not the custom for two brothers to marry two sisters. The Andarabi preference is for the sons of one father (or mother) to spread their marriages diversely, and the daughters of one father (or mother) also. As this custom is an important clue to the local culture—although perfectly consistent with orthodoxy—I try to examine it further.

First of all, it is apparent that, with the prevalence of patrilocal domicile (82 per cent male householders residing within the father's village) and **village** in-marriage (65 per cent of extant marriages),¹ we can expect a good many marriages to occur with close relatives of one kind or another. I have already touched upon the more common of these, marriage with the first cousin, etc., widow inheritance, and marriage with the deceased wife's sister. I found also several other possible

¹ See p. 38 above.

(a) Co-wives

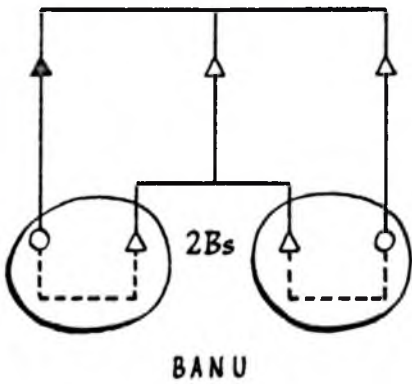
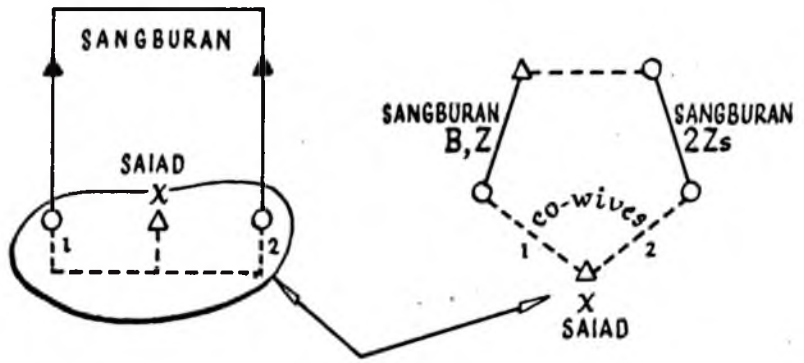

(no prior relationship)

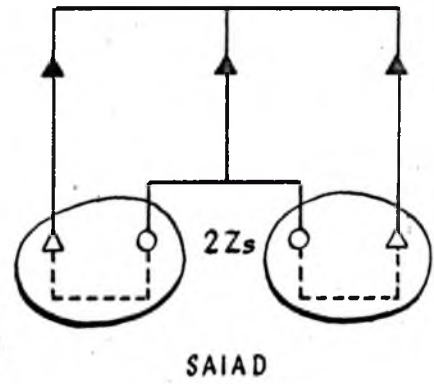
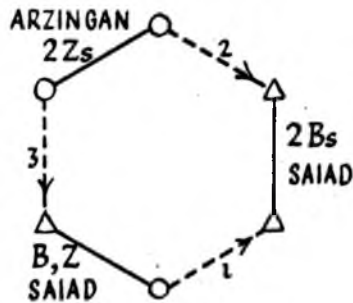

(b) Siblings (same sex)

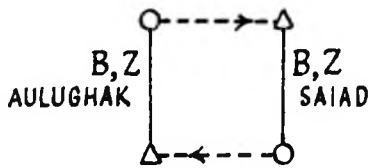

(no prior relationship)

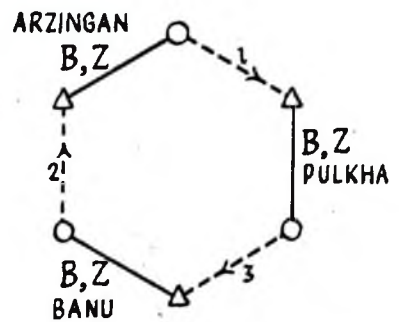

(c) Siblings (opposite sex)

Fig. 5 The closest forms of contemporaneous marriages

(permissible) forms, which occur infrequently or rarely: sister exchange marriages; a father and son marrying a mother and daughter; a father and a daughter marrying mother and son; a man marrying his sister's husband's daughter (who was also his own father's brother's son's daughter); and so on. The closest relationship obtaining between the contemporaneous marriages of two brothers, however, turned out to be that their wives may be patrilateral first cousins to one another; which is also the closest relationship permissible, and sometimes occurring, between the co-wives of one man. In odd cases, the contemporaneous wives of two brothers might be the patrilateral first cousins of their husbands, as well as of one another. Exactly similar considerations apply also to the mutual relationship of the contemporaneous husbands of two sisters,¹ as shown in Fig. 5.

Now the ready Andarabi explanation of this evident avoidance of linked parallel marriages is that they would put obstacles in the way of widow inheritance: if one brother died, the second could not marry the widow, since she would be **his** own wife's sister, and therefore forbidden. In offering this rationalization, the Andarabis are speaking within the Koranic frame of reference, but we must here refer to the social structure as well as to the Koran. (1) If two brothers

1 In successive marriages, there was one instance in the Saiad series (Table 2) of two sisters having been married to father and son, i.e. the son married his father's wife's sister after the deaths of both his father and the father's wife, who was not his mother.

do not marry two sisters, the two payments of bridewealth are made to different men; and, in the further development of their emerging conjugal households, the two brothers are set back to back, as it were, instead of side by side. Their realms of personal kinship are made individual to each, and different from the other. (2) The opportunities are thereby compounded for systematic inequalities among a set of brothers: if one of them is parochially married, within the agnatic cluster, the second will very likely be contrastingly married extra-parochially. (3) The tendency is created for sibling sets of the same sex, whether male or female, to strike out fresh alliances in each generation, as well as serving to cement old ones.

This last point can perhaps be exemplified as follows. Let us disregard prior (inherited) genealogical relationships, and draw up chains linking individuals through conjugal and sibblingship bends only—but giving due weight to the factor of domicile. Fig. 5 (a), (b) and (c) show such chains in the closest forms occurring in Andarab. In the first case, 5 (a), the first two marriages to occur were those of X, Saiad village, to an unrelated woman of Sangburan and then to the first wife's father's brother's daughter, also of Sangburan. The third marriage, which closed the chain into a ring, was that of the first wife's brother with the second wife's sister. The resultant configuration, made from these prior relationships, is, however, very similar to that arising from the three marriages shown in 5 (b), among two brothers and one brother and sister,

(a)

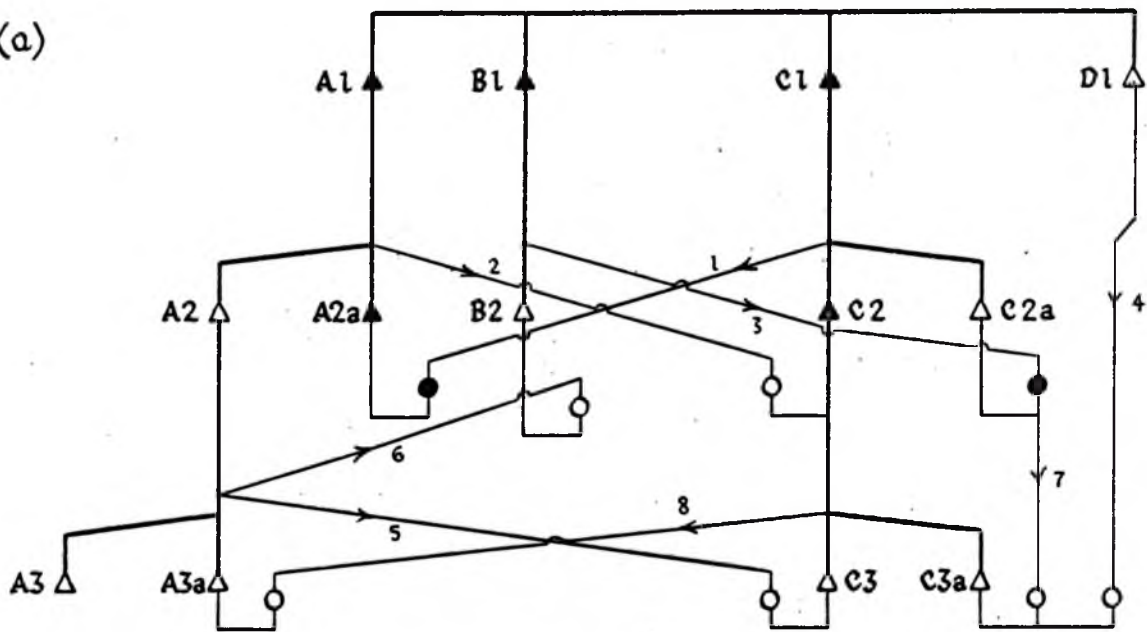

(b)

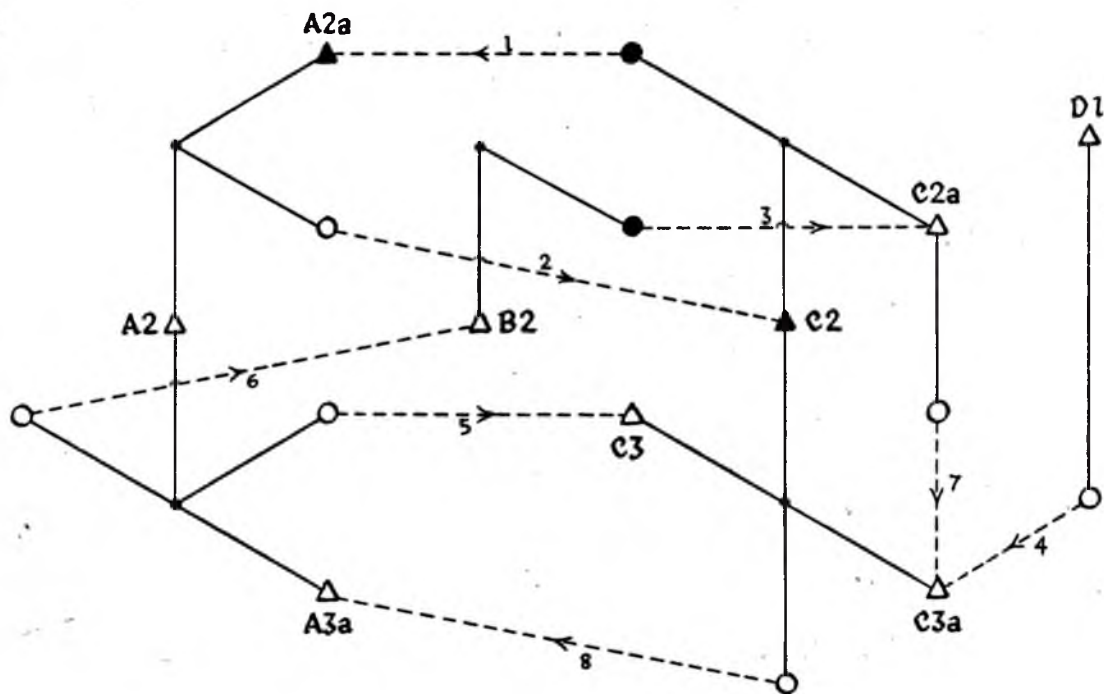

Fig. 6 Marriages within one agnatic cluster (Pulkha)

of Saiad, and two sisters of Arzingan, without any antecedent interrelations. Again, both these configurations resemble in form the third example, 5 (c), arising from the conjugation of three pairs of siblings of opposite sex, formerly unrelated, and with patrilocal domicile in Arzingan, Banu and Pulkha.

Figure 6 gives a fuller picture of the interval configuration within one agnatic cluster, localized in Pulkha village. This is a large cluster. It consists of eight householders, placed genealogically in three succeeding generations: D1, in the first generation; his three older brothers' sons, A2, B2, C2a, in the second generation; and his brothers' sons' sons, A3, A3a, and C3, C3a, in the third generation. All eight men are now domiciled in Pulkha village, although two of them are living away, in employment out of Andarab, C2a in Kabul, C3a in Qunduz. The oldest men, around sixty years, are D1 and A2. (Within one set of brothers, the older is shown on the left, the younger on the right.)

Fig. 6 (a) shows the interconnections among the mature progeny of A1, B1, C1 and D1 (in generations 2 and 3) in the conventional way; while 6 (b) attempts to show their intermarriages, numbered seriatim, 1 to 8, more clearly. For simplicity's sake the diagrams do not show the wives who had married into the group, nor the daughters who had married outside it. The omitted daughters are three: (i) one daughter of A1, married to an unrelated man in Pulkha, as against her sister, married to C2, a father's brother's son; and (ii) two

daughters of A2, each married to her own mother's brother's son, in Banu and Tal-i Mir Ghazi villages respectively, as against their two sisters who married parochially, B2 (a FFBS) and C3 (a FFBS as well as FZS). As regards the omitted wives (living and dead) of the second and third generations, they numbered eleven: (i) six married by A2, from different places (Tal-i Mir Ghazi, Banu, Sangburan, Sar-pul and Kishanabad, in Andarab, in that order, and the sixth from the northern city of Mazar-i Sharif), as against A2a, who married only C1's daughter (a FBD); (ii) three married by A3, again from other villages (Arzingan and Sangburan), and again in contrast to his younger brother A3a's parochial match (a FFBSD as well as FZD); (iii) one married by C3 (from Kishanabad) for his second wife, while the two marriages of C3a (to FFBD and FBD) were both parochial; and finally (iv) one married by C2a (from Kishanabad) for his second wife. As far as I knew, there were no prior close relationships among these eleven incoming women, or between them and their respective husbands (my informants were A2 and A3).

It is evident from this account that linked parallel marriages between two brothers on one side and two sisters on the other are somehow avoided, whether the opportunity offers within one agnatic cluster or outside it. The general trend is towards a pattern of diversification among the marriages of siblings of the same sex, resulting in the separate development of their respective individual alliances. Distinctions

as regards the quality and the number of their marital connections always appear among the sons of one father, and usually favour the older as against the younger. Through arriving on the scene early, oldest sons often enjoy, moreover, a closer and longer-lasting relationship to the father's undivided material estate, while youngest sons who mature last also tend to inherit the least. (See section 4, below.) Such inequalities among brothers arise partly from the father's customary preference of the older over the younger, and partly from the unavoidable consequences which large age differences among coparceners must have in a system of partible inheritance. They bear little or no relation to the different matrilineal connections inherited by the sons, whether by one or more wives.

The configuration within the agnatic cluster of Fig. 6 is the result of such conditions operating in three successive generations. The net effect is to distinguish the living group according to two opposite aspects: A1's older issue (in the second and third generations) are placed in radiant "star" positions, with more than half their personal connections occurring outside the local cluster; D1 and his issue, and C1's issue in both succeeding generations, are so connected as to form short internal loops only, with hardly any external relations; the open-ended marriages occurring on one side contrasting with the inward closing, cul-de-sac marriages on the other. The relative socio-economic standing of the eight

men within the cluster, which I have omitted to detail here, conforms almost exactly the same pattern.

It may not seem very felicitous to distinguish marriage patterns into parochial versus extra-parochial, or star versus satellite, but I think such terms are of greater heuristic value than formal genealogical classification. The eight internal marriages of Fig. 6 can be formally classified as:

- | | |
|----------|-----------------|
| 1. FBD;* | 5. FFBSD/ MBD;† |
| 2. FBD;* | 6. FBSD; |
| 3. FBD; | 7. FBD; |
| 4. FFBD; | 8. FFBSD/ FZD;† |

* Sister exchange

†Sister exchange

and this mode surely conceals the customary avoidance of linked parallel marriages, which I have discussed.

I conclude this section by mentioning that I did find such marriages to have occurred in Andarab in only one case, where three daughters of one man had been married to three out of the seven sons of another man. Both sides were Muhammadzai Sardars, immigrants to Andarab. As members of the ruling "clan" of Afghanistan, the Muhammadzais customarily marry mainly amongst themselves; but from some of their other genealogies I examined in Kabul, it appeared that linked parallel marriages among them are further connected with the formation of segmentary lineage groups, such as are not found in Andarab.

TABLE 3

Terms of kinship in common use

<u>Andarabi usage:</u>	<u>Reference:</u>	<u>Andarabi usage:</u>	<u>Reference:</u>
bābā (P.)	FF, MF	zan* (P.)	W
bībī (P.)	FM, MM	shūi ⁺ (P.)	H
padar (P.), ata (T.)	F	khusur (P.)	WF, HF
mādar (P.), apa (T.)	M	khushū (P.)	WM, WF
'ammuk (Ar.), kākā (P.), awa (T.)	FB	khusurbura* (P.)	WB
'amma (Ar.)	FZ	khīyāshna* (P.)	WZ
tagha (T.), māmā (P.)	MB	aywar ⁺ (P.)	HB
khāla (Ar.)	MZ	yāna ⁺ (P.)	HZ
barādar (P.)	B	anbāgh ⁺ (P.)	co-W
kh'āhar (P.)	Z	boja* (T.)	WZH
yanga (T.)	BW	bola (T.)	MZC
yāzna (T.)	ZH	<p>1. All terms given are relative to an ego of either sex, except where marked (*) = Male Ego, or (+) = Female Ego.</p> <p>2. The six terms for F & M, B & Z, S & D, take the suffix <u>-andar</u> (P.), or <u>-oghai</u> (T.), to denote the relations MH & FW, FS/MS & FD/MD, HS/WS & HD/WD, respectively. Thus MH = <u>padarandar</u>, FW = <u>mādarandar</u>, etc.</p> <p>3. (P.) = Persian; (Ar.) = Arabic; (T.) = Turkic.</p> <p>4. F = father; M = mother; B = brother; Z = sister; S = son; D = daughter; C = child; H = husband; W = wife.</p>	
barādarzāda (P.)	BC		
kh'āharzāda (P.)	ZC		
bacha (P.)	S		
dukhtar (P.)	D		
kēlin (T.)	SW		
dāmād (P.)	DH		
nawāsa (P.)	SC, DC		

3. The kinship terminology

A short account of Andarabi kinship terminology may provide some formal confirmation of the scope and method of reckoning kin relations. The terms of kinship in common use (Fig. 7) are specific and particular, rather than classificatory; they show an equally specific interest as between the paternal side and the maternal side, and a developed interest in affinal kin. There exists a noteworthy paucity of self-reciprocal terms. Most of the terms are the normal Persian (including some Arabic loans long since naturalized), but there is a sprinkling of Turkic terms, mainly as alternative usages (see Table 3). All terms are used as terms of reference more often than in direct address. Relatives of the ascending generations, and near collaterals considerably senior in age, are addressed either by the kinship term, with or without the suffix of endearment (jān), or else by some honorific. Relatives of the descending generations and younger collaterals are addressed by personal name. A man does not address his wife by name, but by an exclamation "Ay!" or as the mother of so-and-so, naming her child, or as the daughter of so-and-so, naming her father. A wife may also exclaim "Ay!" to her husband, or name him with the suffix Khan.

Table 3 is a complete list of the specific terms of Andarabi kinship. The terms of reference or address needed to denote further relationships are made up by the formation of descriptive

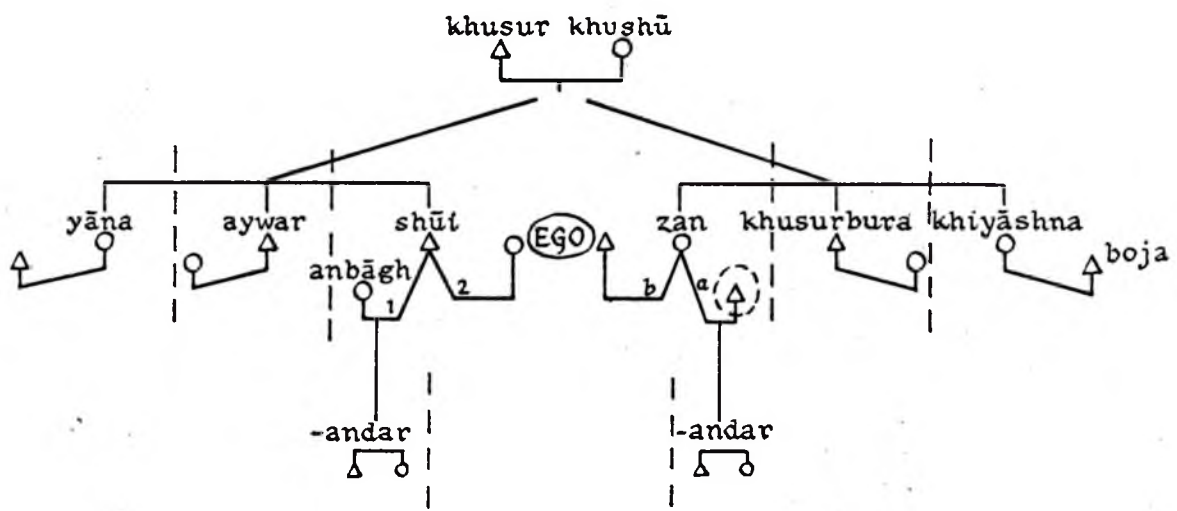
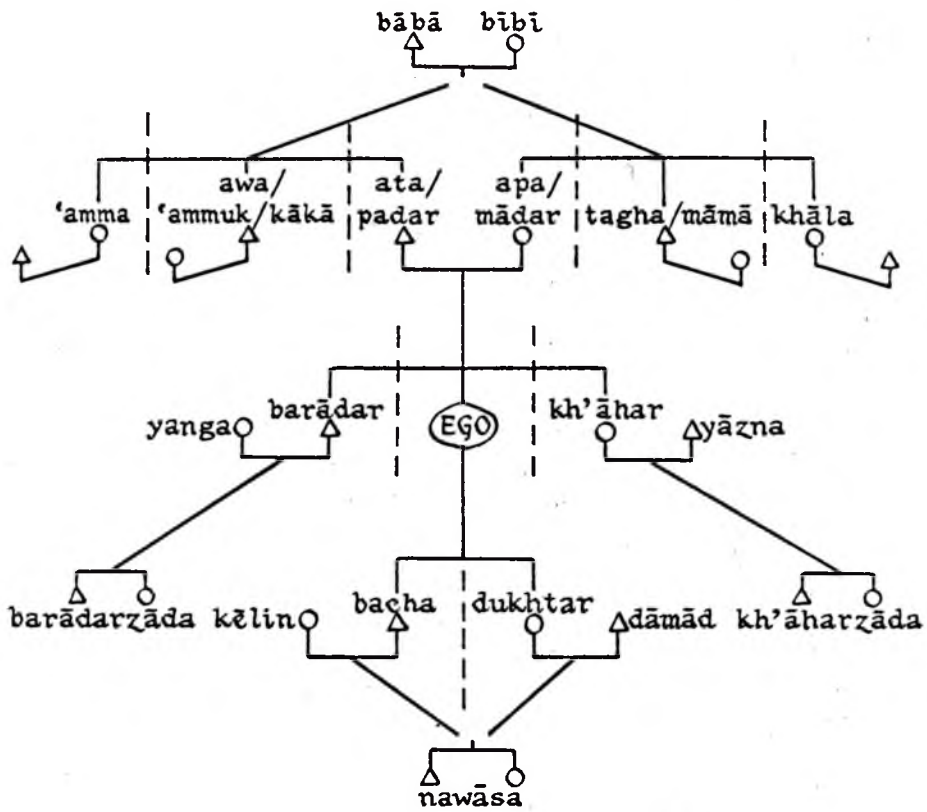

Fig.7 Terms of kinship in common use

Points of household bifurcation indicated thus: |

compounds, as explained below. In one case, a specific term (yanga, brother's wife) is extended further in a classificatory manner.

The relationships additional to those of the elementary family, and which occur within the polygynous household, or through the remarriage of a widowed or divorced woman, are described by terms formed from the primary terms by the addition of an adjectival suffix, -andar or -oghai. A wife of Ego's father is thus mādarandar, a second husband of Ego's mother is padarandar, corresponding to the English usages "step-mother" and "step-father"; Ego's spouse's son, bachandar, "step-son", and Ego's spouse's daughter, dukhtandar, "step-daughter". Ego's full brother or sister are similarly distinguished from Ego's paternal or maternal half-brother or half-sister by the application of the adjective sikka or zāyida in reference to the former, and andar or oghai in reference to the latter (FS/MS = barādarandar: FD/MD = kh'āharandar).

The children of Ego's grandchildren are awāsa (a diminutive modification of the single term for grandchild), and the parents of Ego's grandparents are bābā kalān, "great-grandfather", and bībī kalān, "great-grandmother" (kalān meaning "great").

The spouses of Ego's collaterals of the ascending generation are referred to by the descriptive formations zan-i 'ammuk (wife of father's brother), shūi-i 'amma (husband of father's sister), zan-i tagha (wife of mother's brother), and shūi-i

khāla (husband of mother's sister). In addressing these relatives, however, a more classificatory principle is employed, inasmuch as Ego's father's brother's wife, and Ego's mother's brother's wife, are called yanga, the term of address and reference for Ego's own brother's wife. The term of address for Ego's father's sister's husband and mother's sister's husband is āqa, corresponding to "sir", by which Ego's own sister's husband (vāzna) is also addressed. These classificatory usages are consistent with the common position of these relatives at the outer edges of the "relative" prohibited degrees of marriage, explained in the preceding section (cf Fig. 4, lines aa' and bb', and pp. 106-7).

Ego's patrilateral and matrilateral, parallel and cross cousins, are referred to by specific compound terms, taking into account their sex, bacha-i 'ammuk and dukhtar-i 'ammuk for son of father's brother and daughter of father's brother, and similarly bacha-i (S of) or dukhtar-i (D of) in conjunction with 'amma (FZ), tagha (MB), or khāla (MZ). Only in the last case, that of Ego's matrilateral parallel cousin, does there also exist a specific, self-reciprocal term (bola), corresponding to the English "cousin", for the mutual mode of address between the children (at any age) of two sisters. This term bola is a further recognition of the special kinship relation between two sisters, which is indicated by the usage boja, for the mutual mode of address of the husbands of two sisters (Fig. 7, Table 3); it is again connected with the "relative"

prohibition whereby sisters may not be co-wives. There is no corresponding specific term by which the wives of two brothers may call one another.

Ego's spouse's father's brother and sister, and mother's brother and sister, are called by descriptive formations which correspond to "such-and-such in affinity", kākā-khusur (spouse's FB), 'amma-khushū (spouse's FZ), tagha-khusur (spouse's MB), and khāla-khushū (spouse's MZ). The spouses of the brother or sister of Ego's own spouse, are referred to descriptively, by prefixing zan-i (W of) or shūi-i (H of) to the specific terms for Male Ego's wife's brother (khusurbura) and wife's sister (khiyāshna), or Female Ego's husband's brother (aywar) and husband's sister (yāna), except that in the case of Male Ego's wife's sister's husband, the specific usage (boja) already mentioned, is available instead. A child of Ego's spouse's brother or sister, is similarly described by prefixing bacha-i (S of) or dukhtar-i (D of) to the same four terms (WB, WZ; HB, HZ).

There are, finally, two kinds of category formation which are important indicators of Andarabi kinship reckoning. One is concerned with the newly formed relationships in affinity—"one's in-laws" in English—in Ego's own generation, and in the generation succeeding Ego's; the second is concerned with Ego's agnatic cousins. The first points to the new links of personal kinship created by marriage; the second to the inherited patrilineal framework provided by a generalized body

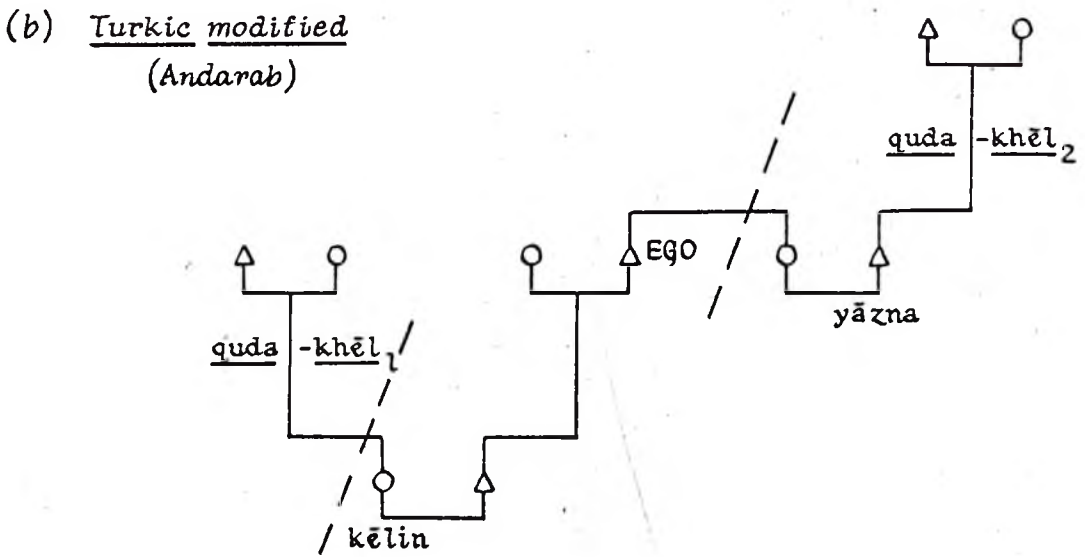
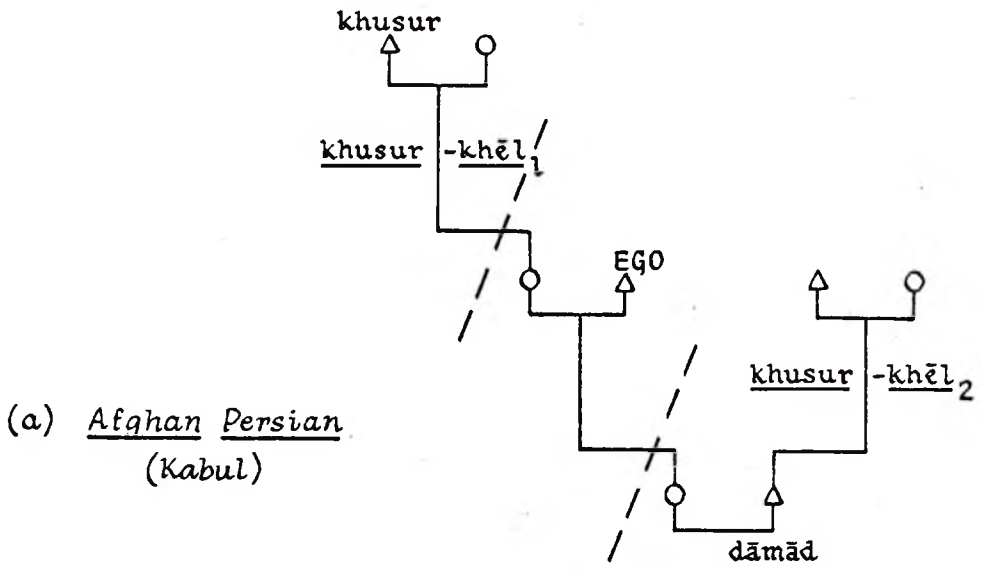

Fig. 8 Categories of affinal kin

of co-resident males.

The Andarabi reckoning of kinship through affinity is done according to two systems of different origin, the general system of Afghan Persian, and a particular modification of the Turkic. In the Afghan Persian usage of Kabul, a man's affines are of two kinds, both of which are referred to as khusur-khēl, from khusur, wife's father, and khēl, a group, faction, literally a body of men, a troop. The khusur-khēl are defined as the kindred of one's wife's father (padar-i zan), and of one's daughter's husband's father (padar-i dāmād), as shown in Fig. 8a. In Andarab also, the parents, siblings, etc. of Ego's wife, are reckoned as khusur-khēl; while those of Ego's daughter's husband are reckoned as dāmād-khēl, after dāmād, daughter's husband. All these are Persian terms. In the Turkic system of origin, on the other hand, the single term quda, is employed to refer to the parents, etc. of Ego's daughter's husband, as well as of Ego's son's wife. It is thus a self-reciprocal term, used for the mutual mode of address between the two sets of parents of one married couple. This is modified in Andarab somewhat; the quda-khēl are the parents, siblings, etc. of Ego's son's wife (kēlin), or of Ego's sister's husband (yāzna), as shown in Fig. 8b. The effect of this modification is that quda is not admitted in the common usage of Andarab as a self-reciprocal term, which was the essential characteristic of its original Turkic use. At the same time, as can be seen from Table 3, the intermediary

relationships, kēlin (son's wife) and yāzna (sister's husband), through which the Andarabi quda-khēl are determined, are themselves denoted by Turkic terms.

We are consequently obliged to accept the Persian system and the Andarabi version of the Turkic system, as representing equally meaningful categorizations of affinal kin in Andarab. They are not merely accidental collocations, nor is one of them a superfluous alternative. I cannot be sure of the practical extent to which the terms are employed by the female Ego as against the male Ego, but it is clear that their reference is to four kinds of viri-patrilocal domestic family to which Ego's own conjugal household is directly connected by wife-giving or wife-receiving, in Ego's own generation and in the next generation of which Ego is a parent (Fig. 8). It is a matter of personal kinship and domestic access, deriving from the residential change of a woman upon marriage from her family of orientation to her family of procreation.

As regards the modes of address, in the speaker's own generation, Male Ego may commonly address his sister's husband, as well as his wife's brother, by the personal name, with an honorific suffix, or with the suffix of endearment (jān). A slight distinction between the two relatives is indicated by the fact that a man can address his wife's brother more intimately and familiarly, as "tagha", "mother's brother", a term of casual informal address for any older man; while the sister's husband is addressed more formally, as "āqa", "sir".

In the ascending generation, the wife's father as well as the sister's husband's father are addressed respectfully as āqa; and the wife's mother, and the sister's husband's mother, as "khushū", the equivalent of "mother-in-law". In the descending generation, the son's wife is addressed by the kinship term, kēlin, and the daughter's husband (dāmād) commonly by his personal name. The parents of the kēlin and the parents of the dāmād, who are of Ego's own generation, are distinguished mildly in address, the parents of the son's wife being addressed more intimately (as "tagha", "mother's brother"/ "khāla", "mother's sister") than the parents of the daughter's husband ("bābā", "grandfather"/ "khushū", "mother-in-law").

To my knowledge, Andarabis do not show the same interest in reckoning affinal kinship through Ego's brother's wife (yanga), as they do through Ego's sister's husband (yāzna). Ego may address the brother's wife's parents in the same way as the brother does, but Ego is likely to refer to them merely as "my relatives (kh'ēsh)".

The only other category formation of Andarabi kinship is that concerned with the category of Ego's agnatic cousins. It is based on the descriptive specification which is employed to refer primarily to Ego's father's brother's son. This descriptive specification is bacha-i 'ammuk, son of father's brother, and in its linguistically less specific form of 'ammuk-bacha, it is extended to cover all further agnatic cousins, of whatever degree or remove. A reference to Fig. 9 opposite, will make the distinction clear.

The kinship term 'ammuk or kākā may be used to address Ego's father's brother, and its further derivatives, kākā-i kalān (great kākā) and kākā-i bābā, are applicable in reference to the father's brother of Ego's father, and of Ego's father's father, respectively. These agnatic grand-uncles would be actually addressed as "ammuk" or "kākā". All agnatic uncles in return refer to the speaker as barādarzāda, "brother's child", and address him or her by name. This is the limit of near collateral agnates, as reckoned in practice.

When we cross the boundary into agnatic cousinhood, no specific kinship term is available at all. The first cousin is commonly referred to as bacha-i 'ammuk, and on occasion this may be extended to a living first cousin once, etc. removed. All agnatic cousins, except only the first, are normally 'ammuk-bacha; and all cousins, including the first cousin, address one another by name, with the addition only of any honorific owed to age, etc. It can thus be readily understood why the indefinite term 'ammuk-bacha should be the one (and only) kinship term frequently used as a synonym for gaumi, one who is of the speaker's local community; the reckoning of agnatic cousinhood is sufficiently diffuse for it to stand as a synonym for "fellow villager", and the mutual obligations which ~~the two~~ signify are equivalent. On a long and ramifying patrilineal genealogy originating from a common ancestor or a set of brothers, Ego possesses effective agnatic kinship, and reversionary coparcenary rights, only as far as

those living near collateral agnates who are not cousins; that is the limit of Ego's own agnatic cluster. The mutual relations among agnatic cousins are contingent upon their personal kinship.

4. Agnatic clusters of households

Clusters of co-resident near collateral agnates may be regarded as constituting political factions within the village community, little parishes within the parish. Our discussion of marriage patterns showed a characteristic criss-crossing of internal connections within the little parish, accompanied by systematized differentiation among its individuals in relation to the outside world. In this section, I seek to show that the differentiation occurs in other spheres besides those of marital alliance, so that every agnatic cluster occupies an oblique position in relation to its general social and economic environment. The dissimilarity and inequality noticed among the sons of one father in relation to their marriages, tend to apply also to their inheritance, despite their formal equality in Koranic and customary law.

We find every particular agnatic cluster, whether numerically and genealogically small or large, existing at any period as a system of mutual attractions and repulsions, cooperation as well as competition, among the individual households; but almost invariably with an underlying order of differentiation

defining a star-and-satellite system. The several auto-cephalous households can be arranged into a "head", "body" and "tail", when judged according to the criteria of:

- (1) the paterfamilias' ownership, occupation and income;
- (2) the size and lineal extension of his individual domestic family; and
- (3) its external connections acquired through marital alliance.

The total configuration of the cluster according to these circumstances forms the true framework of competition and cooperation; and determines the actual and potential leaders and followers in local affairs at any one time. Within a single cluster, the order of differentiation generally favours the earlier as against the later descended collaterals, of whatever degree, but it is not at all rare for some paternal uncles to follow rather than lead their older brothers' sons.

An order of seniority and precedence is recognized among the sons of one father, according to their age. An older and a younger brother begin to be differentiated early in terms of occupation, education, and the number or socio-spatial quality of their marriages. After the point when the controlling hand of the father is removed, an older brother can prevail more easily over a younger if there is a great difference of age between them, or if they are by one mother. The senior may stand to the junior in the place of the father, directing his labour and arranging his marriage, etc. In the condition of several, well-spaced marriages on the deceased

father's part, as is common among polygynists, the succeeding generation is very likely to include full brothers and father's sons of widely differing ages. If they continue in joint estate for a sufficient period, it would mean the oldest son enjoying the paterfamilias' status and the exploitation of the undivided patrimonial estate for almost the span of a generation. He could develop a polygynous household for himself, and engage in the business of leadership in local affairs, or some other non-agricultural occupation, while his brothers worked the land. The bridewealth received at the sisters' marriages would accrue to him. At the point when his brothers finally partitioned from him, he could emerge with his nominal part share of the patrimonial inheritance considerably augmented. By contrast, the youngest son could never succeed to any more than his appointed fraction of the patrimonial real estate, computed as at the time of the father's death. If he had to pay bridewealth from this to marry, his fractional inheritance might not prove viable in independence; he might be obliged to sell out to an older brother, father's brother, or outsider, and move elsewhere to begin afresh. Ex-coparceners do not necessarily extend a helping hand in personal matters as against the political; and, in Andarab, it is most often younger brothers and younger paternal uncles who are obliged to move residence.

On the other hand, a set of brothers and father's sons may partition and develop their households in severalty early—

either because their age differences are small and there are no minor sons whose maturity should be awaited, or because the different surviving widows and newly-married wives exacerbate contentions—in which case all of them would inevitably be faced with a decline from their father's position in the world. A situation of leadership in the local community held by him might be attained by some father's brother or pass to some other group within the village.

There is at least one constant between the two courses described. In later life, when they have developed their own conjugal households independently, a set of brothers show less inclination to turn their backs upon one another. They attempt rather to re-align themselves by arranging one or more alliances among their children. Father's brother's daughter marriages are a characteristic fate of younger sons. It is expected that this will be so, and such betrothals are frequently made during the wards' minority. They are an element of solidarity and mutual support within the group.

The characteristic order of differentiation within one agnatic cluster arises from the operation of such conditions over two or more succeeding generations. The particular sequence of demographic development over this whole period of time is of crucial importance in determining the contemporaneous situation, i.e. the numbers of the group, and the relative age and genealogical status of individual members. Owing to the system of partible inheritance operating in each generation,

the relative socio-economic standing of the individual households is intimately affected by the past demographic sequence. It is equally important also to know which individual paterfamilias was or is engaged in a specialist occupation whereby he could amass wealth, in contrast to others who were or are labouring merely on their own patrimonial acres, and still others who, unable to marry and hold their own on their inheritance, had to forego patrilocal domicile.

The total political configuration at any one point in time is the resultant of all these factors, and cannot be specified without making reference to them. In general terms it can be stated that the leaders of the village community are the older, wealthier and better connected men of the largest agnatic clusters. The agnatic cluster intervenes as a factional subdivision between the unit of the individual household and the village community as a whole; it is a longer lasting entity than the household, and it represents mutual rights and obligations which are weightier and more definite than those which bind together the village community at large.

I can illustrate this account from a particular cluster located in one section of Saiad village. It is more compact genealogically than the Pulkha cluster described before to show the marriage patterns (Fig. 6), though the present cluster is larger in size. The socio-economic differentiation will be more emphasized here than the marriage patterns, for it is important to appreciate that the lines of division with regard

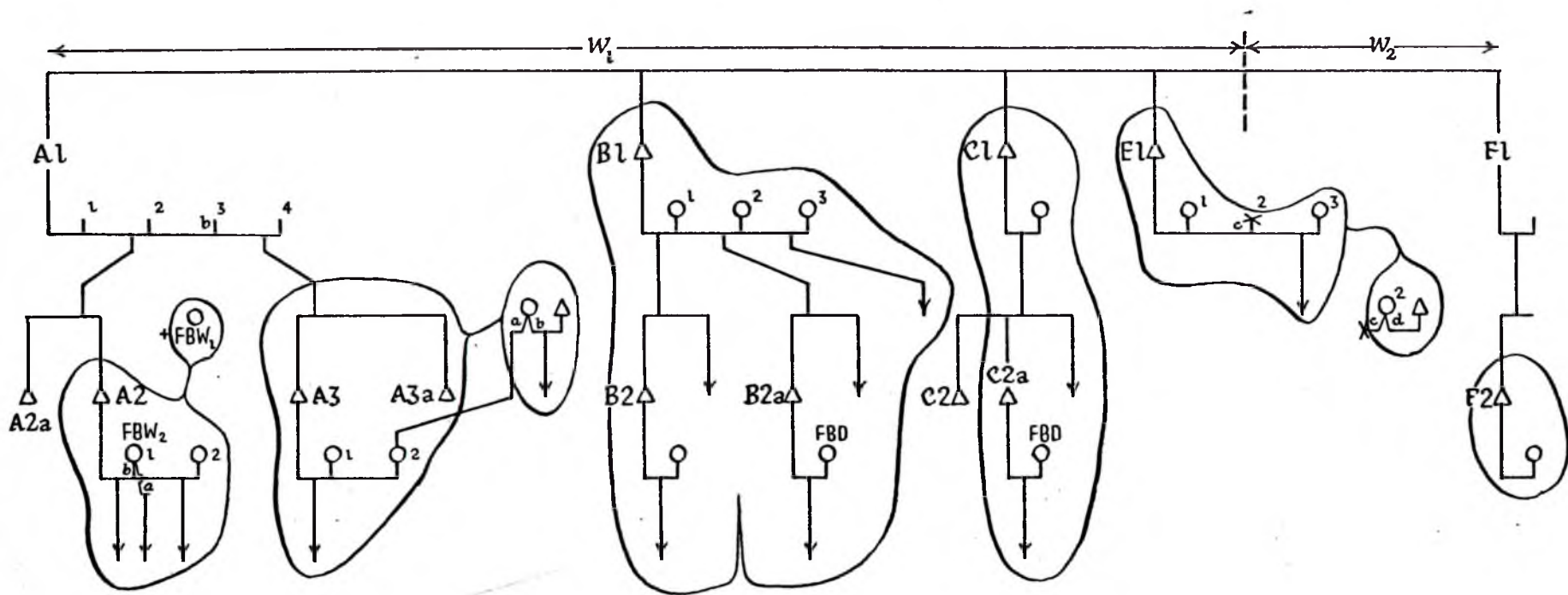

nuclear
family

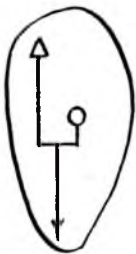

Fig. 10 Household composition & development within one agnatic cluster

(D1, the deceased brother intervening
between C1 and E1, is not shown)

to ownership, occupation and income, proceed within as well as between adjacent agnatic clusters in one locality. In Andarabi social structure generally, territorial divisions and socio-economic differences cut across one another, and the smallest territorialized segment of collateral agnates is no exception to this.

The particular cluster shown in Fig. 10 is formed (as always) around an older man (B1, aged fifty-five), and includes, besides his own sons (B2, B2a), his living younger brothers and their sons (C1, C2, C2a; E1), and his deceased brothers' sons (A2, A2a; A3, A3a; F2). B1 is the oldest of all; F2 is the oldest of the second generation; A2 and A3 are of about equal age; A2a and A3a are their respective younger full brothers, A3a being an unmarried youth; B2 is slightly older than B2a, C2 than C2a. The dwellings of two of these men, A3 and E1, include also another married couple each, who are affinal accretions, not practising joint house-keeping with their host families. Conversely, A2a, recently married, is now living uxoripatrilocally, apart from his brother, but in the same village section; and C2, who is still single, is away from home in paid employment outside Andarab. B1 is the Saiad village headman; C1 is the Public Censor (muhtasib) for Andarab district;¹ E1 is a Deh Salah shopkeeper. The others' occupations will be mentioned below. Fig. 10 concentrates on the composition of the six households composing the cluster, and also indicates the three parochial marriages

1 A religious office of mild and diffuse duties; cf p. 49 above. C1 also acts as the mullah for his village section.

in the second generation (A2's 1st wife is a widow of the deceased D1 (not shown), whose daughter is married to C2a; and B2a is married to E1's daughter by his 1st wife). A fourth marriage, that of F2, can also be classed as parochial (see below) though for non-genealogical reasons.

This whole cluster of ten variously aged married males and two marriageable youths (C2 and A3a) originated from a single founding ancestor (Ao, not shown in Fig. 10). Like all agnatic clusters, it owes its numbers to polygynous marriages in successive generations, aided by demographic good fortune in the proliferation of male descendants as against females. The founder, Ao, was the village headman of Saiad for a time, and his eldest son (A1) after him; his second son B1 is the present headman. This three-fold succession did not occur automatically or continuously; there were certain breaks, during which the office was held by two other men, belonging to other sections of the village. This also is typical of Andarabi politics.

After the death of Ao, his six surviving sons, by two wives (A1,...E1; F1), continued jointly under the eldest, A1. In this case, partly for the reason that five of the six brothers were by one mother, their joint phase lasted unusually long. During it A1 succeeded to his father's status as village headman, built up his own position in the locality, and multiplied his marital links. A1 was pre-deceased by his father's son, F1, who left a widow and a minor son. A1 married the widow as his third wife (her "b" marriage), and was enabled to exploit F1's

portion of their father's estate. (After Al's death, this woman got passed in marriage to the youngest surviving brother El. This was her "c" marriage. El later divorced her, when he had two wives of his own, but she was still not allowed to leave the group. Although old and past child bearing, she was married ("d") to a poor immigrant from another district, and she and he both still live under El's roof, a most unusual case of co-residence. At the same time, the immigrant man's daughter by a previous (deceased) wife was also taken into the group, by marriage to F2, the genealogically juniormost man. In this way neither was a widow allowed to exit the group, nor did a divorced wife remarry within the group. F2 got an inexpensive wife, and no outside connections via her, a match befitting his peripheral situation.)

In one way and another, Al was able to bequeath an estate (110 sēr irrigated land, 400 sēr dry farming, and a gal'ah valued at the equivalent of 15 sēr irrigated when the estate was partitioned among Al's sons) which was much more substantial than the individual portions (of Ao's estate) succeeded to by his five brothers (totalling 130 sēr irrigated and 210 sēr dry farming). Al died in the prime of life, and leaving no son old enough to make a bid, so B1 assumed leadership of the group and attained the village headmanship. B1 also utilized both positions to feather his individual nest, consolidating himself as a polygynist, making a good outside marriage for his oldest son (B2) and an internal match for his younger son

(B2a, married to E1's daughter by his 1st wife), gradually buying more land etc. (starting from an inheritance of 25 sēr irrigated land, B1 now owns 100 sēr, some of it purchased from A1's older son, A2). As this cluster of Ao's male descendants grew and did well, through effort and favourable circumstance, some others in the locality were declining, in numbers as well as possessions. If this had not been so, and if Ao had started with too little property, the set of six brothers would have been obliged to disperse from their village section in the very first generation, instead of coming to dominate it in the second. Ao's original impetus had come from the successful practise of pastoralism as against agriculture, but his descendants are peasant proprietors only.

Meanwhile, D1 died not long after A1, leaving one widow with a young daughter, and a second widow with two infant boys. The daughter was married to C2a, the younger son of C1, with no cost to the latter. The two widows joined the household of A2 who could not, however, inherit anything from his father's brother, over the heads of the deceased's surviving brothers. He did marry the widow with sons but only through giving a sister of his in exchange to the widow's brother (her marriage guardian, living in another village). Moreover, the landed property of the deceased D1 passed under the care of B1 as the deceased's eldest surviving brother. B1 will relinquish it to D1's sons upon their maturity (i.e. not to A2, but to A2's step-sons), meanwhile delivering some produce (to A2) for their and the widows' support.

At present, B1's establishment is the most self-contained and independent in terms of property, as it is the most developed in terms of demography. The two grown sons can work the land conscientiously, while the father is engaged in the business of village headmanship, and the labour of the five women of the house is not without good effects.

This ideal is approached but not wholly achieved by the household establishments of C1 and E1, and the men in the second generation fall substantially short of it. C1, the mullah and muhtasib, sent his older son, still single, to work for wages with the Afghan labour corps in Khinjan, while the younger, married to his father's brother's daughter, stays at home training to be a mullah under his father's direction (C1 and C2a are the only two literates out of the cluster's twelve adult males). As C1's muhtasib duties necessitate travel around Andarab's remoter villages (where he collects payments and gifts ostensibly for putting people on the right path, and ensuring that no community is without its mullah), the family is rather short of agricultural labour. Its land is let out, on a sharecropping chārikāri basis, to a fellow villager (a father's sister's son to C1, residing in the same village section). E1 runs a grocery shop in the Deh Salah bazaar nearby, dealing in wheat and rōgan (clarified butter), with a capital sum borrowed from a wealthy Khan (of Pulkha village) against fixed interest; B1 stood surety for E1 in this. As E1 has no grown sons, and owns no draught animals, he also

has let out his land to a sharecropper of this village section (a daughter's husband of B1).

In contradistinction to these earlier matured brothers—and particularly in contrast to A1 and B1 who stood successively in their father's place vis-à-vis their younger brothers—F1 came upon the scene too late to do more than first serve his elders and then attain to minor peasant proprietorship. He did not practise any more specialized occupation. In the second generation, F2, his only son, married parochially in the sense explained (p.131), and is barely holding his own. He is in debt to an outsider for consumption loans; has no surviving children; and has to hire oxen by the day to plough his fields.

At the opposite end of the scale from F2, in the second generation, the four sons of A1 are better disposed. They partitioned first along the lines of their different mothers (A2 and A2a on one side; A3 and A3a on the other); A2 and A2a then subsequently divided when the younger married recently and went to live with his wife's father (in the same village section). A3 was formerly in partnership with E1 in the Deh Salah bazaar, also with capital borrowed from the same Khan (of Pulkha); he is presently away on national service with the army, and his younger unmarried brother (A3a) works on their joint lands. A3 and A3a divide their produce equally, but the shopkeeping income belonged to A3 alone. On the other side, A2, who recently returned from national service outside

Andarab, and is about the same age as A3, seems to be without visible means of support in the future. He is a spendthrift, averse to working or managing land, and when A3a married and split from him (a year ago), he found himself obliged to sell all his inherited land to B1.¹ A3a was also obliged to sell some of his inheritance to pay bridewealth to his wife's father (an unrelated man), with whom he took up residence. A3a made his sale to a local shopkeeper (one to whom F2 is in debt). As he has not yet an establishment of his own, A3a has let his land to the same man as does sharecropping for C1 (the latter's father's sister's son).

A2 and A3's marital alignments also differ considerably. Although not married parochially, A3 is married to women fairly closely related to the three men in the ascending generation: his first marriage was to his father's mother's brother's daughter (i.e. B1's mother's brother's daughter); and the second to his agnatic second cousin (i.e. B1's father's brother's son's daughter). A2's marriages reflected his inherited connections in a different direction: he married first his father's brother's widow (D1's widow), through sister exchange with her brother; and secondly the daughter of a friend of his deceased father's, otherwise unrelated.

1 When I asked E1 (my main informant, although I had some acquaintance with the others) how A2 proposed to manage, E1 replied, "He lives on the rights of women!" referring to the fact that B1 delivers him the produce of the deceased D1's land for the support of the latter's widows and infant sons, as explained on p. 132.

We may conclude from this investigation that, if we arrange the cluster of male agnates in the order of their age and genealogical status (Fig. 10), i.e. according to the degree of proximity to their closest founding ancestor, we can observe a coherent system of inequalities, manifesting themselves in three interrelated spheres. There is a serial order of differentiation, first, in terms of household structure and demography (as shown in Fig. 10, ranging from B1: extended polygynous family, eight married persons; to F2: incomplete nuclear family, two married persons); secondly, in terms of the socio-spatial range of personal kinship, especially as reckoned through the wives; and, thirdly, in relation to the socio-economic grading (property, occupation and income) of each male householder, and the (self-contained) labour resources of his domestic unit. Since the particular individuals who are favoured in the system of inheritance are also favoured in the system of marriage, and therefore also in terms of future demographic growth, the inequalities in the three spheres tend to reinforce one another: B1 is the best placed in all regards, and F2 the worst, all factors considered. But there is no necessity that this must always be so. The serial order of differentiation may be seriously different in the different regards and, when this occurs, the leadership position becomes correspondingly confused. If the system of inequalities becomes dislocated (e.g. if B1 were to die suddenly) the "star-and-satellite" configuration no longer prevails, and can only be re-established

around a successor (A3, B2 or C1) after a period of competition and disarray.

The factors which hold the cluster together, at any period, are: first, the strong reversionary rights among coparceners; second, the close overlapping of their personal kinship, as reckoned through patrification; and, third, their "parochial" marriage alliances. Common domicile is also a necessary factor, for any effective relations are difficult to maintain without it. Agnatic kinship is thus less an entity in itself, and more the resultant of these several specific contents. Without them, remoter agnatic cousinhood ('ammuk-bachagi) is only a faint genealogical memory overlaid on the ordinary bonds of established village fellowship.

5. An illustrative case

Of course, most men in a given community have only a very few near collateral agnates, and some have none. Nevertheless, the slightest burgeoning of the direct line of patrilineal descent is vitally important, partly for the negative effect which this has on individual inheritance, and partly for the opposite, positive reason that only on this basis can any comparatively stable factions emerge within the local community. Other alignments are secondary, changeable and shifting. I present in this section a particular case history

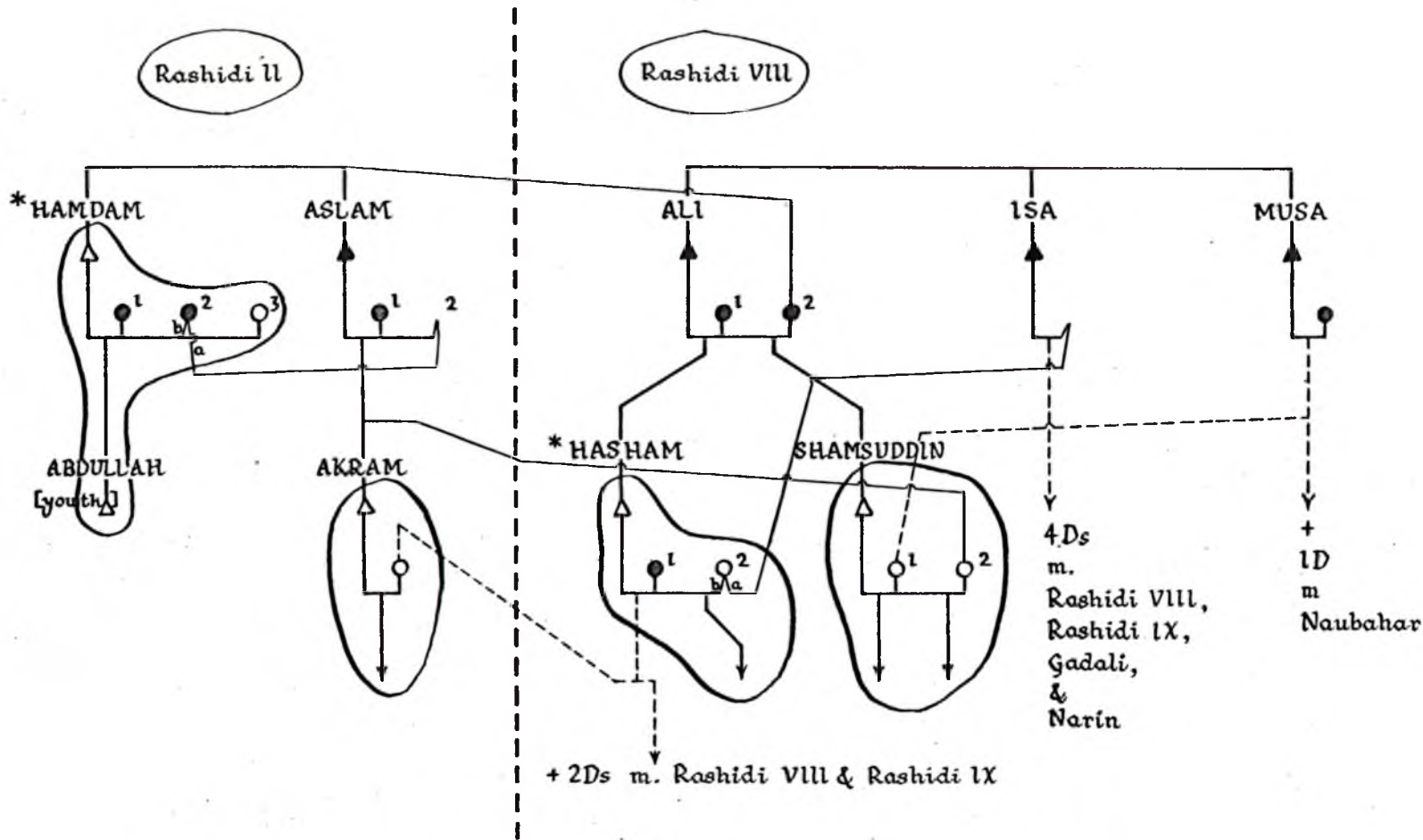

* Not shown: 3Zs of HAMDAM m. Rashidi VII, Rashidi IX, & Dehzak, respectively;
 2Zs of HASHAM m. Rashidi VIII (both).

— = no male issue,
 Ds only.

Fig. 11 Illustrative case of MBD marriage

which concerns two small agnatic clusters of one village, involved over a disputed marriage. I could have selected some more obviously "political" dispute, such as competition for village headmanship, or the election of a deputy for Andarab district, but the number of individuals, agnatic clusters and local communities involved would be too great to handle simply. The relevant social groupings will find ample reference even in this small unit of narrative; and it nicely illustrates, within a short compass, some of the general statements made in the foregoing sections. Since it concerns marriage, and coming into one's inheritance, and the Andarabis were earlier quoted as saying that all their quarrels are over either women or landed property,¹ the present example can stand as a "typical" dispute.

Fig. 11 shows the relevant genealogical interconnections among the principals, at the present day. The dispute, concluding with the simultaneous marriages of AKRAM and SHAMSUDDIN to his second wife, occurred five years ago, when AKRAM was a barely marriageable youth, and ABDULLAH still a child. The relative ages of the others can be inferred from Fig. 11 and the narrative itself. The Roman numerals suffixed to the name of the village, as Rashidi II, Rashidi VIII, etc. refer to the different sections of that village, and specify the parties' domicile. (Rashidi is in Qasan valley; Dehzak and Gadali are adjacent to it on either side.) I retell the story below in almost the same form as it was told to me by

1 Pp. 69-70.

my INFORMANT, who is a remoter agnatic cousin of HASHAM and SHAMSUDDIN, living in the same ancestral compound (in Rashidi VIII) as they do. It should be borne in mind that the principal parties are all middling peasant proprietors.

(a) The mother of HAMDAM (and his three full sisters) was from Khost; ASLAM (the younger brother) and his sister were from another mother. (b) ASLAM did not show sufficient regard for his sister, and she started talking of her share of the paternal inheritance. (c) ASLAM answered her, "When I have a daughter, I'll give her to your son free [i.e. without demanding bridewealth], so you can stop this share talk!" He committed himself to it with a prayer in company (in front of ALI and other witnesses), though nothing was put in writing.

(d) After one year ASLAM's wife bore triplets; two died, one (daughter) survived. At this time SHAMSUDDIN, (second) son of ALI, was five years old. (e) As the girl's father (and mother) died before her puberty, her legal marriage guardian was HAMDAM. ALI (and his wives) were also deceased by this time. SHAMSUDDIN's attorney (and guardian) was HASHAM, his elder brother. (f) HAMDAM said to HASHAM to set afoot the ceremony, as the girl was almost mature, but HASHAM did not exert himself for his brother; he cared nothing.

(g) Meanwhile, the girl had developed a fancy for one Alam, son of Fazal, in Rashidi III, where she used to go with her mother, to visit her mother's brother. (h) The women, including INFORMANT's mother, commended SHAMSUDDIN to her, but she declined him. It was rumoured that she had other boy

friends besides Alam.

(i) HAMDAM again spoke to HASHAM, but this mean fool did nothing. (j) Now HAMDAM, who had a (full) sister married in Dehzak village, wanted to covertly give the girl to someone there, a son of Karim. (k) The Dehzak people's bridewealth was settled. They made payments in cash and kind to HAMDAM; and got to the point of reckoning sheep for the slaughter for the marriage feast, though HAMDAM did not let anything be known (in Rashidi) outside his dwelling-house.

(l) INFORMANT, his local community, and all village sections of Rashidi, now became informed. Rashidi VIII and Rashidi III (where the girl's and AKRAM's mother originally belonged) were particularly behind SHAMSUDDIN in public assembly. Rashidi I also wanted to defend Alam (Rashid III), whose mother was from there. (m) Next nightfall, when the Dehzak suitor's party was supposed to come to Rashidi II, to feast and take away the girl, forty men of the rest of Rashidi embattled themselves on the road, armed with guns, pistols, knives, etc. The honour of Rashidi was at stake for them. (n) When Dehzak was told of this, they did not come.

(o) In the morning, SHAMSUDDIN's "five greybeards" (of Rashidi VIII) went to confront HAMDAM, who put all the blame on HASHAM, and said that the girl was now committed to the Dehzak people; their money had been accepted (but the matter was stayed for the moment). (p) Afterwards, two days later, SHAMSUDDIN went and petitioned the district secretariat (Banu).

The DEPUTY COMMISSIONER immediately nominated and sent a committee of three assessors (the normal procedure). (q) The assessors went to HAMDAM's (Rashidi II) for the night, and received 800 afghanis (£8). Then they came to Rashidi VIII's mosque, to examine SHAMSUDDIN's evidence, and received 1,000 afghanis. (r) The DEPUTY COMMISSIONER subsequently summoned the Rashidi people to Banu, and SHAMSUDDIN and HAMDAM had to spend more money on the officials, as well as on their Rashidi partisans who supported them there. The DEPUTY COMMISSIONER, QAZI, and COMMANDANT OF GENDARMERIE, agreed not to prefer any charges officially. They entered nothing in the books, and said to go and settle it among themselves.

(s) The Dehzak people were quiet in this. Then, seeing that HAMDAM would come out in the wrong, they came and asked him for their money back. What HAMDAM had expended was on their behalf, and they had provided it covertly. (t) HAMDAM told SHAMSUDDIN's partisans in Rashidi that he would agree to a settlement on condition that the girl's brother, AKRAM, was provided a girl (in exchange for his sister), and HAMDAM himself a sum of money, so that he could reimburse the Dehzak people.

(u) SHAMSUDDIN accepted readily, as he was very keen on the girl, who was indeed attractive. (v) But HASHAM was "kicking to the sky," because the only girl to give AKRAM immediately would be his daughter. (SHAMSUDDIN had no full sisters surviving, and was too young to have an old enough

daughter; HASHAM's full sisters, and his second wife's daughters—his own father's brother's daughters—were already married.) HASHAM declared SHAMSUDDIN not to be his brother, and so on. (w) Hitherto the two had been in joint estate, but they now partitioned everything. HASHAM agreed to part with his daughter on condition that SHAMSUDDIN compensated him with 15 sēr (two acres) irrigated land, one milch cow, etc. The latter accepted this also.

(x) SHAMSUDDIN borrowed from some people against his land, becoming indebted for 17,000 afghanis (£170) that year. He paid HAMDAM; and went with HASHAM to disentangle themselves from the secretariat. They got the original petition back, and tore it up. (y) Finally, SHAMSUDDIN was married; and AKRAM also, two days afterwards. (z) It all took three or four months (from the point where the Dehzak people intervened).

A few points should be added to explain the structural frame of reference of the narrative. (1) It begins with, and assumes throughout, a system of oppositions among conjugal households. ASLAM and his full sister, members of one elementary family, already owed allegiance to separate households when SHAMSUDDIN's marriage was first envisaged. (2) The nearest collateral agnates are nevertheless reckoned as one entity for the exchange or circulation of women. On the one hand, HAMDAM was willy-nilly obliged to help AKRAM to come into his own and the latter married without paying bridewealth. (Formerly AKRAM's inheritance was in HAMDAM's possession, since ASLAM

died and HAMDAM married the widow as his second wife.) On the other hand, HASHAM was obliged to provide his daughter on SHAMSUDDIN's behalf, despite every protestation to the contrary.

(3) Each marriage, in its turn, affected the developmental alignments within the agnatic cluster: HASHAM and SHAMSUDDIN became fully partitioned, and SHAMSUDDIN made over part of his inheritance to his brother; on the other side, partly by demographic chance, AKRAM is now ahead of ABDULLAH in household development. (4) Since the two sides were domiciled in different village sections, their respective local groups were automatically involved: the marriages were celebrated as between Rashidi VIII and Rashidi II. (5) Owing to HASHAM's dilatory tactic, and HAMDAM's covert attempt to bestow his ward on an outsider, the dispute rose finally to the level of opposition between two village communities. The majority of Rashidi people felt that the Dehzak people were taking unfair advantage while SHAMSUDDIN's suit was still pending; they acted to stop the intrusion. Their collective stand served to limit the extent to which HAMDAM could follow his own inclination to the detriment of SHAMSUDDIN, though SHAMSUDDIN alone bore the costs of pressing his claim. (6) SHAMSUDDIN's recourse to the administration had much the same effect, of simmering down the dispute and encouraging a compromise, for the longer the litigation continued the more both sides would be mulcted, and HAMDAM could not be sure that he could recover his expenses from either SHAMSUDDIN or the Dehzak party.

In my informant's account, HASHAM's unseemly dilatoriness and lack in advancing SHAMSUDDIN's cause was put down to his personality alone. But there is also the fact that SHAMSUDDIN now has a conjugal household twice the size of his older brother's, so perhaps HASHAM found the insistence on his second marriage over-ambitious for a younger brother. As people told me, HASHAM is an oaf and a donkey while SHAMSUDDIN is a man, a description which is meant to apply to their achievements in the world as well as to their characters. To come into his own, SHAMSUDDIN indeed had to pay two bridewealths (one to HAMDAM and one to HASHAM, for both marriages which took place; and in contrast to ASLAM's original promise to bestow a daughter on SHAMSUDDIN "free"), and this correspondingly diminished his inheritance, but a man is a man for all that in Andarab. An alternative deduction could be that there is no denying the claims of the old men (HAMDAM and HASHAM), who came out best in material terms, while the kinship initiative, so to speak, passed to the younger generation (AKRAM and SHAMSUDDIN).

HASHAM and SHAMSUDDIN are now wholly partitioned and no longer set one above the other in one joint household. Yet the dispute which provided the occasion for their separation also further interwove their realms of personal kinship; SHAMSUDDIN's second wife's brother is also HASHAM's daughter's husband. The legacy of joint kinship which they inherited through patrification was given a new shape in the contemporary network, not completely broken up and dissipated with time and the pressure of present choice. Likewise, in the

realm of property, the legacy of their father's brothers, ISA and MUSA, who died when comparatively young, fell to them together; aside from being the agnatic heirs, HASHAM is now also ISA's widow's husband and SHAMSUDDIN MUSA's daughter's husband. Should any other daughter's husband of ISA or MUSA choose to stir against them, HASHAM and SHAMSUDDIN would be as one. The system of partible inheritance certainly sets the male coheirs in competition early, but they have at least the permanent common interest to exclude outside claims reckoned through females.

The important effect of the demographic sequence on the course of this dispute is apparent readily. (1) ASLAM's original commitment was certainly made in the likely expectation that his two marriages would bear more than one daughter, though it turned out otherwise. If AKRAM had had two sisters, one might have been bestowed on ABDULLAH (if he had arrived rather earlier), and one on SHAMSUDDIN with less fuss.

HAMDAM's individual interest would have been met, and the Dehzak suitors need not have entered the competition.

(2) Even as things stood, if SHAMSUDDIN had had a full sister, to exchange with AKRAM, HASHAM might not have felt so pinched about caring for his brother. Matters would have begun and ended between two agnatic clusters. (3) Apart from the intrinsic merits of SHAMSUDDIN's case, and the provocation given by HAMDAM's covert approach to Dehzak, going behind the back of the Rashidi community, the main reason why SHAMSUDDIN's supporters were more numerous than HAMDAM's was that the

former could trace many more active local links, in various ways, than could the latter, who was virtually isolated. (SHAMSUDDIN's two FDs (HASHAM's full Zs) were recently married in Rashidi VIII, and also one FBD of his and his 1st wife's; HAMDAM could count no near allies in Rashidi II, and few elsewhere.) (4) In terms of their extant size, there was very little to choose between the two agnatic clusters, though it was relevant that HASHAM and SHAMSUDDIN were two male householders as against one.

It should not be noted, lastly, that the socio-economic background of the principals was relevant in two respects. Firstly, if they had belonged to a higher stratum their respective agnatic clusters would have been larger and this would certainly have affected the numbers of their supporters. Secondly, if they had been poorer, the converse would be the case, and the dispute would not ramify so widely within and without the local community; neither could the principal parties afford to spurn compromise until the stakes escalated to such a high point. The poor cannot quarrel mightily or for long; whole villages do not muster in their support, and the mere threat of administrative intervention can still them.

We may thus conclude that a good deal of historical and demographic, as well as sociological, investigation is required to elucidate any dispute; the fact that at its terminal point, in formal genealogical terms, one man married his mother's brother's daughter, and the second the grand-daughter of the

man who was married to his father's sister, is the least of it. We must take into account the structural oppositions among households, clusters of close collateral agnates, and local communities, as well as differentiation according to socio-economic criteria—groupings which give content and direction to individual interests and also limit the individual's freedom of action. The developmental position of the principals is never the same at the end of any dispute as it was in the beginning; important and irreversible changes are likely to have occurred in the disposition of their respective domestic, kinship (agnatic as well as non-agnatic), and local, alignments; and it is in these terms that the genesis and course of the contest is best understood. Certain fairly definite limits are placed on the spread and duration of particular contests by (a) the threat of physical violence and reprisals (along the lines of division between separate households, agnatic clusters and local communities); and (b) the fact that costs of material expense on third parties (i.e. mainly the administrative mulct, secondarily the rewards of partisans) are chargeable to the individual disputants, and no one else.

Questions of marriage and inheritance, obviously vital to the individual's developmental position in the world, are the common stuff of contention; but other matters, such as homicide, are similarly fought out. Again, while the slayer's near agnates, other kinsmen and local partisans, will stand by him in the ensuing confrontation, particularly before the

administrative authorities, they will expect to be compensated for their trouble. Blood-money, like bride-wealth, comes out of one individual's estate only. Moreover, the slayer is often expected not only to make material restitution to the deceased's heir, but also provide or promise him a daughter in marriage. The Andarabis do not make such a contrast between good dealings versus bad, as between close relations versus distant. Their proverb is that "The near enemy is nearer than the distant friend."

These matters are personal as well as communal, involving the individual's personal kinship connections as well as the local group. In those representational concerns which are pitched at a higher political level, such as the election of an Andarabi deputy, the individual is submerged within the local community, and voting follows the territorial basis. Villages and, to a lesser extent, electoral wards, form single factional units and vote en bloc. In such matters, gaum, the local community, including the agnatic group, comes before kh'ēsh, the individual's network of personal kinship.

CHAPTER V

THE AFGHAN STATE

In the administration of the Afghan state Andarab occupies the position of a district (hukūmat-i mahalli) in the Pul-i Khumri division (hukūmat-i kalān) of Qataghan province (vilāyat). The province is divided into three divisions (Talūqan, Qunduz, Pul-i Khumri), each comprising a number of districts, and sometimes sub-districts (alāqadāri). The Pul-i Khumri division comprises four districts: Ghorī, Doshi (with two sub-districts, Khinjan and Tala-o-Barfak), Andarab, and Narin (with one sub-district). The province is in the complete charge of a Governor (nāib-al-hukūma, lit. viceroy), under whom are the divisional Commissioners (hākīm-i kalān, or hukumrān), and under them the Deputy Commissioners (hākīm) of the district (a sub-district is administered by an alāqadār, who is the hākīm's subordinate). The territorial boundaries of provinces, divisions and districts follow closely the geographical contours of the country (Map 1). All districts are ranked into three grades according to their administrative importance (Andarab is a grade 1 district).

The chain of executive command thus runs from Kabul to Baghlan to Pul-i Khumri to Banu, and the same route is followed in reverse by representations and appeals. It has been said

of the administration in general that "Afghanistan is a highly centralized state run by telephoned orders from Kabul to the provincial governors and by word of mouth to lower levels".¹ As the government telephone extends to Banu (routed from Baghlan, via Pul-i Khumri and Doshi), the telephoned orders can be clearly heard in Andarab, at least by the Deputy Commissioner (there is only one telephone); but the Afghan state is nevertheless not as centralized as it appears at first sight. It is a young organization which, while it has quite thoroughly supplanted the various principalities which preceded it, is superimposed upon, rather than fully integrated with, the diverse regional communities within its territory. The constituent units enjoy more local self-government than they seem to on paper, as I hope to show in this chapter. Moreover, the comprehensive code of shari'at, Islamic law, still occupies a larger place in the life of Afghanistan than do statute law and administrative law; and there can be no doubt that the people's adherence to their religious traditions has limited the independent growth of the state.²

Over the last forty years the administrative structure has been considerably enlarged and modernized; and procedures laid down for the division of departmental functions, from the ministries in Kabul downwards. It is still possible to

1 D.N. Wilber, ed., Afghanistan (New Haven, Conn., 1956), p.91.

2 See also Ch. I, pp. 5-7.

say, however, that there is more delegation of executive authority and responsibility down the hierarchy than across it at any level. The governors, divisional commissioners and deputy commissioners are like miniature monarchs—or little prime ministers—each with total charge of a progressively smaller domain; despite the fact that different departments exist, with manifestly separate functions, and direct responsibility to their respective ministries in Kabul. The courts, particularly, do not function independently. The general system can be described as one of government by the chief executive-in-council, the "council" consisting effectively of departmental functionaries as well as representatives of local and sectional interests. The official elective council at the highest level, the National Assembly, is the most hamstrung; but, especially at the lower levels, there are other effective customary channels by which the people can influence the governing process, albeit informally and unofficially. Only through considering these procedures can we penetrate the appearance of personal rule, sometimes arbitrary, by a hierarchy of chief executives.

The individual official's career lies with his particular ministry or department, which functions on a nationwide basis, and within which he is recruited, posted, transferred and promoted. Officials are rotated from one district or province to another every few years; it is government policy never to appoint officials to their home districts. Almost all leading

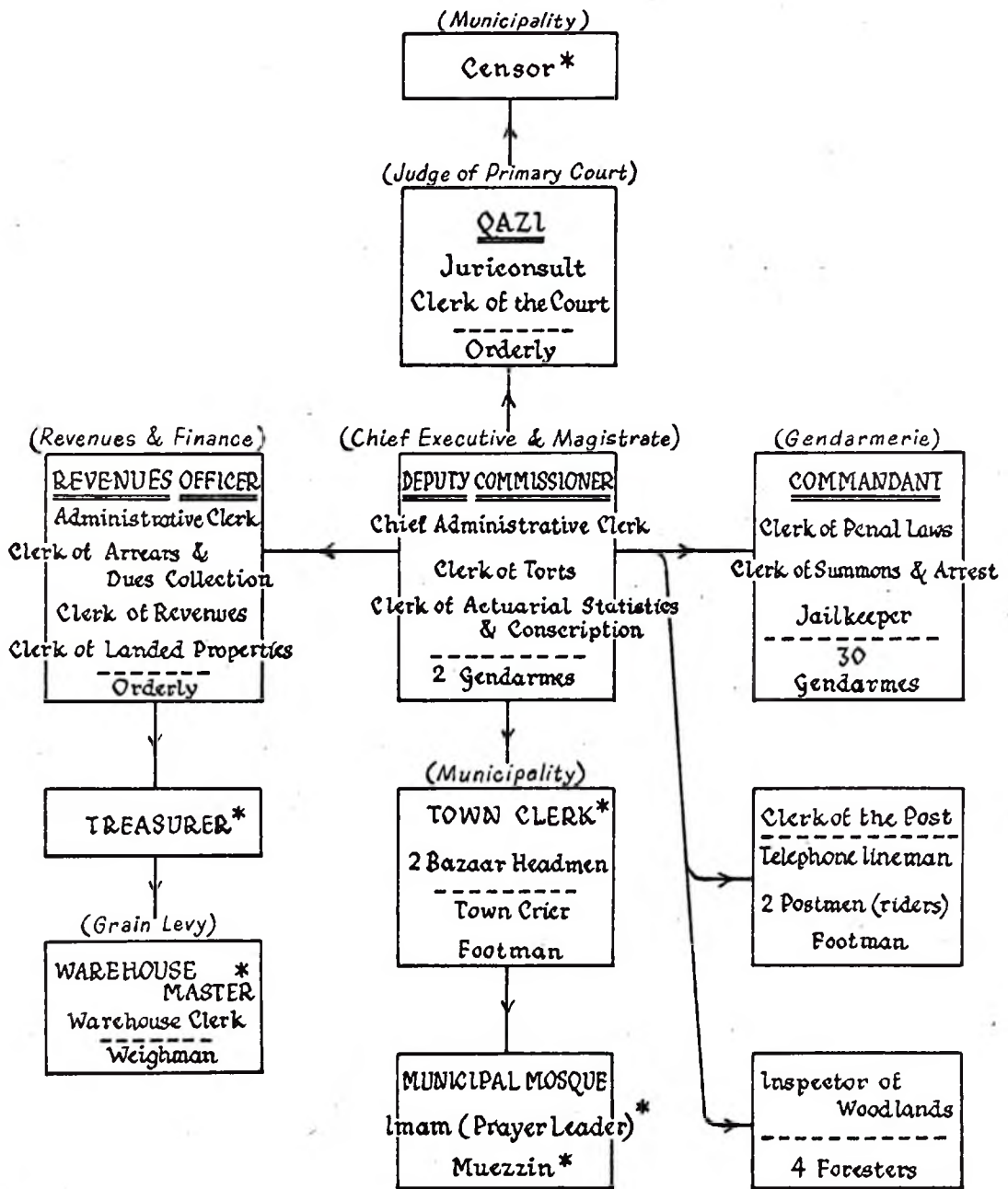

COMMISSIONED OFFICER
* LOCAL APPOINTMENT

Fig. 12 The district secretariat

officials are Afghans, mainly from Kabul, the Eastern province and Qandahar. "The government thus rests on the local population as a kind of foreign organism."¹

1. The district secretariat

The Afghan state is instituted and represented in Andarab by the group of officials and small garrison of (thirty) gendarmes housed in the district secretariat buildings (hukūmati) in Banu. The personnel of the state schools are also part of the state establishment (Ministry of Education), but they take no part in local government as such, and are not represented on the district secretariat. The four chief (commissioned) officers are the Deputy Commissioner (hākīm, Ministry of Interior, Administrative Branch), the Commandant of Gendarmerie (zābit-i amniyah, Ministry of Interior, Security Branch), the Officer of Revenues and Finance (māmūr-i māliyah, Ministry of Finance), and the Judge of the Primary Court (qāzi-i mahkamah-i ibtidāyah, Ministry of Justice). The Revenues Officer is the first deputy to the Deputy Commissioner, and officiates in his stead whenever the latter is absent; the Qazi is the second deputy. The Ministry of Communications and the Ministry of Agriculture are represented at the district

1 H. F. Schurmann, The Mongols of Afghanistan (Hague, 1962), p. 230.

level by junior officials only, who in this case happened to be locally recruited. (The departmental staff of the Governor at the provincial level is more extensive and includes, besides the senior representation of the above Ministries, officers representing the Ministries of Defence, Education, Public Works, Health, the Press Department and the Customs and Excise Department.)

The functions of the various officials are approximately indicated by the manner in which I have translated into English their various titles in Fig. 12. The functional divisions are difficult to specify more accurately even after consulting the persons in charge, and perusing the relevant laws and codes in Kabul, in so far as these are obtainable. The government codes are printed (in Kabul) in limited editions, and are not widely known. There is a good deal of latitude and overlapping in theory as well as practice. The unit of work for every official is the district. The Deputy Commissioner is the executive head of the district (ra'is-i mantiqa), with overall responsibility for the order and rule of this self-contained segment of the kingdom. As such, he is at least the chairman of the district's officialdom, with power of veto on specific issues, and usually much more. The other departmental heads are responsible to their respective superiors at the divisional and provincial levels, but there again the chief executive possesses the controlling power, and is no mere coordinator or figurehead.

The Deputy Commissioner is also the district magistrate. All petitions ('arīza) on all matters, civil, criminal or administrative, are submitted to him in the first instance. He decides what to make of them—if anything, since he can dispose of minor matters summarily, and may dismiss "improper" or "irregular" petitions, without an entry in the official records. Where penal (jazāi) infringements occur he appoints an ad hoc, three-man committee of assessors (haiat) to do the investigation, and prepare a dossier. Any official (usually the departmental clerks, including the Clerk of the Court) may be appointed as an assessor, but the Clerk of Penal Laws should be included. This post, within the gendarmerie department, is a recent innovation, which enlarges the official role of that department; formerly the investigation was immediately under the Deputy Commissioner's Chief Administrative Clerk, and the gendarmerie merely the implementive arm of the Deputy Commissioner's department. One or more gendarmes accompany the committee of assessors in their investigations on the spot, and make such arrests as are judged necessary by the Commandant or Deputy Commissioner. (The powers of detention at the district level are limited to less than one year.) The Deputy Commissioner may either confirm or reject the assessors' report; his recommendation is necessary on all penal dossiers, and usually decisive.

The gendarmerie department then forward the completed dossier to the Qazi's court for the judgment of the case.

Although the Qazi hears the plaintiff and defendant in all cases, and examines the nominated witnesses, he does not act as an independent judge in the criminal cases, but gives the shari'at form and imprint on all that has gone before, and pronounces the punishment incurred according to the traditional Islamic code. His court does in fact include a juriconsult (mufti) to whom these functions properly belong in theory, but I am of the opinion that, at least as far as penal infringements are concerned, the Qazi himself is more a juriconsult than a judge. This does not imply that he is merely a rubber stamp (for the Deputy Commissioner acting as a magistrate), because, as will be explained shortly, even in criminal cases there is one component which the Qazi can dismiss as 'adam-i sam', "incapable of being heard [in court]".

In all breaches of law, whether classified as civil (huqūqi) or criminal (jazāi), liability is fixed according to the following criteria, in diminishing order of importance: (1) confession or admission (iqrār) by the accused or defendant; (2) eye-witnesses (shāhid) produced by the plaintiff or petitioner; (3) administration of solemn oath (qasam) on the Koran to the defendant declaring his non-liability; (4) abstention (nukūl) from oath by the defendant; (5) proof by categorical indications (dalā'il wa qarā'in-i qātia) inferred from the circumstances documented by the assessors. In every action the court procedure is thus much the same: the plaintiff brings legally valid proof, or, if he cannot make good his

claim, the defendant is required to swear an oath of non-liability before the Qazi; if he does so he is discharged. If he declines, the procedure varies according to certain circumstances. The defendant may be assumed to be liable; the oath may pass to the plaintiff; the criterion of circumstantial evidence (5) may be applied; the case may be dismissed as unproven or incapable of being heard; or the plaintiff may be declared a calumniator (muftari, a slanderer and deviser of false tales). Muslim legal procedure, and the Andarabis themselves, take the formally administered oath most seriously. No one will swear upon the Koran lightly and without the greatest consideration, whether in court or elsewhere. The oath is administered to determine complete liability or non-liability; there is no question of making each side swear their respective testimony and then submitting it to judgment.

According to Islamic law there are two distinct rights infringed by a crime: (1) the right of God (haq-al-Allah), and (2) the right of the person (haq-al-'abd); in civil cases the latter only is involved. This introduces certain complications as between the roles of the magistrate and the judge.

When a petition of tort is brought, the administration must first investigate if the defendant admits the claim (igrār) or whether the plaintiff possesses legally valid papers (sanad-i shara'i) establishing his claim. If either be the case, it is a question of enforcement merely, and it is not

referred to court.¹ If, however, the defendant denies (inkār) the claim, the matter must go to court, and the usual procedure ensues; i.e. the plaintiff produces the prescribed eye-witnesses, or the defendant abjures on oath. If the defendant declines to take the oath, the suit lies with the claimant, who must, if successful, pay a "tithe" to the administration, a fee fixed at one-tenth of the value of his claim. The Qazi can simply dismiss the case as 'adam-i sam', incapable of hearing, if he so decides. The Deputy Commissioner's recommendation is not required on civil suits, where what is due to God, haq-al-Allah, is not involved; but he may choose to have the proceedings quashed by declaring that the litigation is against the public interest and the conduct of orderly government.

Penal actions are also brought before the administration in the form of petitions. (Major crimes in any case achieve notoriety quickly; and the thirty gendarmes

1 E.g. sales of land may be transacted 'urfi or shara'i: the 'urfi contract is written, signed by the parties, and witnessed by "five greybeards" and the village headman, but it does not possess legal validity in court; the shara'i official deed of sale (qabbāla) is drawn up by the Qazi after investigating the circumstances, etc. These official documents cost 5-10% of the value of the business transacted, and possess final validity in litigation. See also p. 25, n.1; the greater number of Andarabi contracts are drawn up on the customary 'urfi pattern.

are too preoccupied in delivering summons and chasing and bringing to Banu those who are known to be in default or arrears in one cause and another, to devote much time to general policing duties.) Once such an action has been brought, officially investigated by the assessors, and the dossier duly forwarded to the court, the Qazi cannot dismiss it, for that would be to abrogate what is due to God, the haq-al-Allah, which the state claims as His deputy (kafil). The Qazi goes through the normal court procedure and either fixes punishment upon the defendant, or, contrarily, finds the petitioner a calumniator (muftari), which is also an indictable offence; he does not deliver the verdict of 'adam-i sam'. As to determining the haq-al-'abd, the claim of the injured person, in the same action, it may or may not be substantiated. What usually happens is that the injured party (or his successor, in the case of homicide) accepts compensation, and the two parties sign over to the court an official deed of quittance (ibrā khat). This has the effect of reducing the punishment fixed on the guilty party, to the retribution of the haq-al-Allah alone. It is quite possible, in a homicide action, for the haq-al-'abd part to be dismissed ('adam-i sam') on the grounds that no eye-witnesses were produced, while the haq-al-Allah is determined (at a few years imprisonment, depending upon the instrument employed in the killing, etc.) on the strength of the Deputy Commissioner's report that the person named is the "true doer" (fā'il-i haqīqi).

If it should happen that the infringement of the haq-al-Allah cannot be evidenced in court according to the technical requirements of the shari'at code, the case will go to Baghlan before the Governor in council (the elective council, majlis-i mashvira, which advises the Governor), and the statutory punishment will be fixed according to the magisterial recommendation.

Apart from administering the law, the other main task of the Banu secretariat is revenue collection. Tax is levied on land (māliya, irrigated, dry-farming and orchards; not on common pastures) and livestock (mavāshi, beasts of the pasture) mainly, shopkeepers and tradesmen paying very little.¹ Water-mills and caravanserais are also taxed. The taxes are not excessive in themselves, but they are direct and ungraded, bearing no relation to income. The land registers were first compiled thirty years ago, and are not kept uniformly up to date. They sub-divide the individual holdings into three classes of land, each taxable at a different rate, but I doubt that this classification is on scientific lines. Again, the general count on which the livestock registers are based was last made in 1946, and individuals find it difficult to get their assessments adjusted. The principle applied by the officials is that the total revenue can be increased but not decreased; if they can be persuaded to bring down some one

¹ They contribute also the small municipal revenue: see p. 49.

individual's assessment, they invariably correspondingly increase the liability of one or more others.

Every year, in June or July, the Deputy Commissioner goes on a circuit of the district to supervise personally the collection of the livestock tax, which is the most important single source of revenue. He is accompanied by one or more clerks from the revenues department, the Treasurer, a few gendarmes, and sundry others; the Revenues Officer remains behind in Banu in general executive charge. The Deputy Commissioner's party camp in various places, entertained by the local headmen and Khans; the tour lasts for a fortnight or more, and other business besides that of tax gathering is also transacted. The village headmen are responsible for producing the tax-payers of their village, and ensuring that the assessments of the books are realised before the party moves on to the next group of villages. It is usual for the tax-payers to contribute more than the books specify. First, it is generally expected that for every four afghanis required by the books, one extra should be paid, and this is retained by the officials. The people do not object to this so much as to the further exactions and sharp practices whereby officials realise more than they show on the receipts (which are sometimes held over until the following year), and even the receipts occasionally show more than is specified in the books. The people regard the former 25 per cent extra as a reasonable levy, because known

and understood, and (comparatively) equitably distributed; the latter malpractices are extortions because they are arbitrary and uncertain, falling on some individuals and not on others.

The land tax is delivered to Banu itself, and I had no opportunity to observe its administration at first hand.

Revenue collection has always been an intractable problem in the conditions prevailing in Afghanistan. I should like to quote on it the opinion of Abdur Rahman (Amir, 1880-1901), the man who laid the foundations of the unity of the country and first integrated its system of administration. "Abdur Rahman complained in durbar of the difficulty there was in getting the revenue. 'One quarter of the money,' said the Ameer, 'which is rightly mine, I get without trouble; one quarter I get by fighting for it; one quarter I do not get at all; and those who ought to pay the fourth quarter do not know into whose hands they should place it.'"¹ The present position can be judged from the following. What the central exchequer realises from Andarab district annually (aside from the labour of 300 or so national service conscripts, and some occasional levies) is: the fixed tax on land (270,000 afghanis), livestock (400,000 afghanis), and commerce (a much smaller amount); a variable amount from the "tithe" costs of civil litigation and other legal procedures; and an annual grain levy

1 Stephen Wheeler, The Ameer Abdur Rahman (London, 1895), p. 220.

purchased for the Army at below the market price. All of this amounts to no more than 800,000 afghanis (£8,000). Over and above this, local officialdom realises annually a sum equal to perhaps one-third to one half (in my estimation) of what is delivered to the central exchequer.

It is important to be clear that among the various ways in which this further "private revenue" is realised, plain bribery, which can procure illegal favours and pervert the course of justice, and arbitrary exactions, whereby the poor and ignorant are exploited, constitute a relatively small part. The major part must be looked upon differently.

(1) The official salaries are fixed at a bare subsistence level—the Deputy Commissioner, for example, gets about 500 afghanis (£5) per month plus certain perquisites—and it is accepted by all that state service brings immediate personal gain on the spot, as well as rewards of promotion, etc. We should look upon government posts, at least at the district level, as licensed tax-farming appointments. The 25 per cent surcharge collected on the livestock tax must be placed in this category. (2) Justice and good government are acknowledged, by rulers and ruled alike, to consist not merely in administering the technicalities of the law, but in applying restitutions, composing disputes and stilling clamour, quickly and firmly. The amalgam of traditional Islamic law, well-known and stringent but out-of-date, and

the ill-publicized statutory and bureaucratic codes, which together constitute the law, are in any case complicated and arduous to follow. The Deputy Commissioner's department, the Qazi's court and the gendarmerie department in fact among them compose "criminal" cases as well as penalize "civil" litigants. The system of mulcts (payments being accepted from both sides) **functions** well enough, and I would not describe it as a dereliction of duty, even though money skimmed from Andarab in this way does not find its way into the central exchequer. (3) Since the majority of Andarabis are illiterate, and the apparatus of solicitors and legal counsel does not exist, some part of the payments made to officials can be regarded as fees of commission to prepare and plead the individual's case, either before other local officials or higher authorities with appellate powers. They are very like the fees of commission paid by individuals to village headmen for similar purposes. The total sums realised as "private revenue" from the district (in these three ways) find their way to the district officials more or less according to their rank, the higher provincial officials also receiving a portion.

Obviously, the way in which the system works in practice depends very much upon the personal qualities of the individual officials, particularly the chief executive, and Andarabis always date a particular cause célèbre according to the Deputy Commissioner than ruling, rather than by the calendar. There are certain effective checks on the arbitrariness which

can be exercised by officials: they cannot carry out their basic administrative duties, for which they are responsible to Baghlan and, ultimately, Kabul, unless they retain the confidence of a sufficient number of village headmen, local Khans and men of parts; their own reputation with their departmental superiors depends upon the avoidance of scandal and general outcry in the district, which could lead to their removal; departmental jealousies can lead one official to inform against another's malpractices; and, finally, there are procedures of formal remonstrance and impeachment.¹

1 I can cite two instances from districts other than Andarab. In one case, a Deputy Commissioner was charged with having robbed a shopkeeper's money box while the latter was temporarily absent; in the second, with making advances to the wife of a man in detention. It is general in Afghanistan for manifest charges to be brought in these or similar terms, when what is really alleged is something else—in these two cases, corruption and highhandedness, to an extent which had alienated almost everyone in the district. From Andarab, I cite an example indicating the sensitivity of officials to any defamation of their honour and dignity. A man of Dehzak village, a respectable citizen, had a suit pending against another man. The latter made a considerable payment to the Deputy Commissioner, who put the first man in detention in Banu, without a proper hearing of his case. Spurning to offer a counter-inducement ("Why should I be mulcted when I am in the right?"), the Dehzak man took to resounding the magisterial lock-up with the following verse, which he made up:

"Qadr-i zar rā zargar, qadr-i Kambar rā Ali;
Qadr-i kus rā har kas, qadr-i kūn rā Lohgari."

In translation: "The worth of gold the goldsmith [knows], the worth of Kambar Ali [knows. Kambar was the faithful servant of Ali, the Prophet's son-in-law]; The worth of the pudendum muliebri everyman [knows], but the worth of

Altogether, in my observation, miscarriages of justice and cases of genuine malversation are the exception. I give a few examples below of the sort of thing which commonly occurs in practice.

A fight occurred in Deh Salah village between two factions, in the course of which one MUHAMMAD YUSUF, an unpopular young man, was beaten up. At this time the DEPUTY COMMISSIONER was away on the tax gathering tour, and the REVENUES OFFICER was also away to Baghlan. The QAZI was in charge in Banu. MUHAMMAD YUSUF's father was deceased, and he had no brothers. During the night, his mother-in-law (who was YUSUF's wife's mother as well as a patrilineal relative) went to Banu, and petitioned the QAZI. The next day gendarmes came to summon the six men named in the petition. When they reached the secretariat, the QAZI applied the stick to their leader and refused to listen to them, saying that if they had any right on their side they would have come as plaintiffs not defendants. Three of them were placed in detention. Meanwhile, YUSUF had repented, and agreed with the village intermediaries that his complaint be

the podex the man from Lohgar [knows]." The man from Lohgar was the Deputy Commissioner, and he was being ridiculed as a paederast. More to the point, the detainee's refrain could be heard by everyone within the secretariat limits—including the Deputy Commissioner's wife. (Cf p. 48, para (1).) The gendarmes directed to silence the man with a thrashing tittered while they did it, and after two days he was released. The dispute was left to be composed by restitution among the parties themselves.

withdrawn. The mulct (1,500 afghanis) was paid by the defendants to the QAZI (500), COMMANDANT (400), CHIEF ADMINISTRATIVE CLERK (400), JAILKEEPER (100), and the two GENDARMES on summons (50 each). The original petition was then destroyed, instead of being entered in the books. When the DEPUTY COMMISSIONER heard about the matter, he too agreed to let it pass. (This episode is very similar to the one encountered in the case described in section 5 of the last chapter.)

In another instance, in a case of homicide, where a man was known to have slain his wife, the DEPUTY COMMISSIONER was said to have taken 10,000 afghanis. Nevertheless, on the strength of the latter's report on the case, the man was sentenced to ten years' imprisonment. The haq-al-Allah, due to the state, was not abrogated by the DEPUTY COMMISSIONER's private mulct; and Andarabis did not categorize it as corruption.

My third example concerns a representational matter over the annual grain levy (gōdām). The gōdām is purchased for the Army, each district providing an amount specified by the provincial government. In 1960 Andarab's allocation was announced as 40,000 sēr wheat and 15,000 sēr barley. Andarabis felt that this was excessive; they knew that the state would pay them at substantially below the market price. The village headmen, Khans and others held discussions, and chose four ad hoc representatives (vakīl), one from each

electoral ward, to go and plead in Baghlan that the quota be reduced. They did this with the cognisance and agreement of the REVENUES OFFICER and DEPUTY COMMISSIONER in Banu. The four VAKILS took variously collected sums of money with them to smooth their way in the provincial capital, and for their own expenses. They were successful in getting the quota reduced by 8,000 sēr wheat. Some 30,000 sēr wheat was subsequently actually delivered by Andarab district, to be paid for at 15 afghanis per sēr (when the Deh Salah bazaar price was 22 afghanis per sēr). In actuality the Banu revenues department paid out at 14 afghanis per sēr; the difference, totalling 30,000 afghanis, being divided between the DEPUTY COMMISSIONER (10,000), the REVENUES OFFICER (10,000), and the four VAKILS (10,000). For some hapless citizens, even the 14 afghanis per sēr were hard to collect without offering petty inducements to the disbursing clerks. Nevertheless, there was general satisfaction that things were saved from being worse; and this is one instance where district officials sided with the local people against the excessive demands of higher authorities.

The general Andarabi attitude to the state can be summed up by quoting their two proverbs: "Do not startle the government horses; excepting this, everyone can go which way he pleases"; and, "The wise man does not pass to the fore of authority or aft of a donkey." On the other hand, Andarab is

full of competitive individualists, whose mutual dealings frequently develop into internecine contests of strength, individual and factional. These are continually being referred to the administration: "We have no chief; you arbitrate for us" (to the Deputy Commissioner). It is understood that mulcts will be applied to both sides, graded according to the gravity of the offence or the seriousness of the disturbance created, and according to the rank of the officials involved. The stakes escalate rapidly with every ascent in the official appellate hierarchy. The contest continues until the manly honour of the disputants is satisfied, and a compromise is reached. The original dispute then passes into local history, alongside other scores, settled and unsettled. It is not forgotten quickly, but forms the background to future dealings among all those who were embroiled, either as principals or as partisans.

In these relations between Andarabis and the state, the local religious establishment takes little or no part. The village mullahs and learned maulavis are the spiritual leaders of the community and the caretakers of its religious conscience; they should maintain an attitude of dignified detachment towards the local group's affairs (gaumdāri), which are only too inclined to be fractious. A mullah who is a native of the village, of long domicile, will sit in assembly (majlis, jirgah) as any other villager does and also as a legist, but he will avoid taking sides. During the 1961

elections the opinion of one or two maulavis was sought by some, but carried no great weight. The Imam and Muezzin of the municipal mosque, and the officially appointed Censor of religious observances (see Fig. 12 and pp. 49, 129 n.), have some nominal connection with the district secretariat, but the general mutual relation of the state establishment and the religious establishment is one of respectful aloofness, tending to avoidance.

The exact position of the Treasurer, Town Clerk, Warehouse Master, and two Bazaar Headmen (see Fig. 12 and pp. 49-50), depends upon the way in which they reconcile their function of serving the administration with their situation as local men embedded in the Andarab community. They form part of the secretariat circle, and their fellow Andarabis expect them to help transmit their representations. The Treasurer particularly can be placed in an invidious position, e.g. when he is on circuit with the Deputy Commissioner, gathering the livestock tax. As one Deputy Commissioner put it to me, "Poor man: [he is] government servant as well as compatriot." Only those who can combine the two roles to advantage can last long in these positions; to a lesser degree this applies to all the village headmen as well.

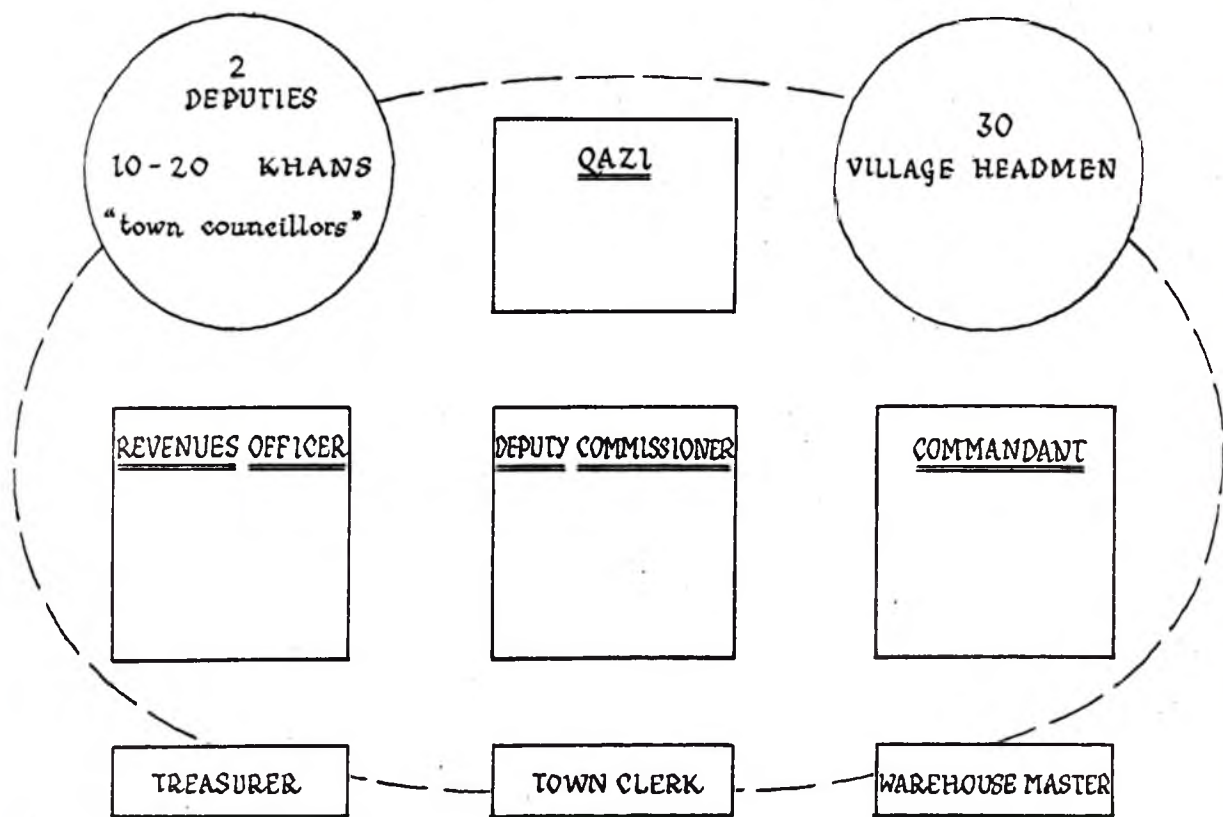

Fig. 13 Effective circle of district administration & politics

2. Administration and politics

Although presenting a pliant and yielding surface to authority, to all outward appearances, the Andarabis are not by nature an obedient people. Many officials find them refractory, litigious, uncooperative. One reason for this is that the Andarabis are incurable individualists and democrats, who like to take their own time to discuss and debate matters in general assembly, instead of merely taking orders, or doing as the great direct. Even amongst themselves, individual Andarabis complain that other Andarabis do not distinguish sufficiently between leaders and followers, the greater and the lesser men; too many weigh themselves as "five-quarters" and want to play politics. As explained in Chapter II,¹ and in the preceding section, the effective circle of local government at the district level comprises the personnel shown in Fig. 13, and the pivotal position in this group belongs to the Deputy Commissioner. I observed Andarab under the rule of two of them, HAKIM X and HAKIM XI, and in this section I describe their respective policies. The two men were very different in personal character and background, and adopted very different attitudes towards the job. A comparison of their two reigns nevertheless brings

1 Pp. 41-45 (village headmen); 48-49 (national and provincial deputies); 52-56 (Khans as "town councillors"; and electoral wards).

out that there are certain constants in the social landscape, in relation to which the strategy, conscious or unconscious, of every ruler must take shape.

HAKIM X adopted a lofty and authoritarian manner, and made himself difficult of access. It was safe to approach him only through certain "courtiers", and his audiences were like levees. There grew up a little durbar in Banu; people said it was better to be "in" with HAKIM X's overseer (a personal servant of his) than to be in the right, if one sought a hearing. To some extent every chief executive must have his councillors; the point about HAKIM X's was that they were a narrower circle than usual, and were chosen strictly on his own terms.

As soon as he arrived, he denounced the state of the roads, the secretariat buildings and furniture, etc. The village headmen were sent for and made responsible for sections of the road (from Darra Kalat to Deh Salah) at the rate of so many centimetres per registered male soul in their respective villages. The gendarmerie department were kept busy in summoning and organizing the labour squad of each village, and HAKIM X himself camped nearby to ensure compliance. All parts of Andarab were made to feel a certain tightening of the reins of government. A few village headmen were declared to be incompetent at this time, and their constituents obliged to change them for more acceptable men;

later on, during HAKIM X's tax gathering circuit, some others were also replaced, either on the grounds that they were dilatory in producing their taxpayers or that there were too many headmen (see p. 40).

HAKIM X next addressed himself to the commercial establishment. He issued an edict, in "consultation" with the TOWN CLERK and the QAZI, fixing the prices of tea, sugar, kerosene, meat, rōgan, wheat, rice etc., at figures below the bazaar rates. A list of the official prices was posted in Deh Salah and Banu, and the bazaar Crier announced the amount of the fine to be paid by transgressors. Since the operations of supply and demand were in no way altered, the only effect was to put shopkeepers at a disadvantage in their relations with the secretariat. Then it was announced that the Thursday market in Deh Salah was abolished; that bazaar was to be closed on Thursdays and the shopkeepers were to go and set up stalls in Banu for the day. Transgressors would be fined 500 afghanis. A few fines were in fact collected in this way, but after a while the insistence upon going to Banu was dropped. The Deh Salah shopkeepers made repeated petitions that they were suffering a serious loss of turnover, since they were reduced to reliance on the Monday market only, but HAKIM X did not relent for the year that he was in office.

HAKIM X also took every opportunity to cut down to size the Khans who had hitherto had high standing in Andarab, and

set next to himself certain others who were more amenable to do his bidding. These others were often from some other "electoral ward". The four electoral wards are jealous of one another,¹ and such shifts in the official patronage of their particular Khans are always occurring. HAKIM X's initiative showed that he fully understood the strategy whereby he could turn their internal rivalries to his own advantage. I illustrate shortly from one episode the manner in which he made an issue. The Khan concerned, KHAN Al, is the richest man in Andarab, and he and his agnatic cluster one of the best entrenched and most prominent.

In winter 1959/60 an order was promulgated from Baghlan forbidding the denudation of woodlands for domestic fuel. This directive could not have been fully obeyed since the "lowland" sources of firewood are insufficient to see through the winter, and the only other course was to cut down fruit trees on an extensive scale. As far as I could see, all that happened was that firewood was no longer brought to the bazaar for sale. At this time HAKIM X sent the INSPECTOR OF WOODLANDS to confront the donkey-loads of firewood being delivered to KHAN Al's place and divert them to Banu instead. KHAN Al's younger son, A2a, was in charge of the wood; he pleaded that he be allowed to take home at least some of it, agreeing to face the HAKIM and pay a fine later. In any case,

1 Cf. pp. 55, 59, 62.

it was dead wood, obtained without harming the natural woodland growth. But the INSPECTOR had his orders, that all of it was to be confiscated. A scuffle then ensued, A2a being alleged to have assaulted the INSPECTOR, who returned to Banu exhibiting a bleeding forehead.

HAKIM X immediately sent six gendarmes and the COMMANDANT himself to apprehend A2a. KHAN A1 was also required, but he knew what was in store and declined to emerge from the inner house. A2a was administered 500 stripes by the HAKIM personally, locked up for two days, and fined 2,000 afghanis. Afterwards, HAKIM X made several reports against KHAN A1 and his eldest son KHAN A2, defaming them to higher authorities, and also made things unpleasant for their relatives and established allies, whenever the latter had business in the secretariat.

Within the secretariat itself, HAKIM X made himself complete master of all the departments. He found fault with the work of various officials, senior and junior, provoking and dividing them, with the end of becoming sole arbiter among them. As a consequence of his machinations the REVENUE OFFICER was recalled to Baghlan, and put through the mill there, pending his transfer to another district. On the other hand, HAKIM X was always careful to appear extremely agreeable and obedient to his own superiors, the Pul-i Khumri divisional COMMISSIONER and, above all, the GOVERNOR in

Baghlan, obeying their every wish with alacrity. They regarded him as a firm ruler, under whom Andarab became a restrained and quiet district, instead of one which continually pestered Pul-i Khumri and Baghlan **with appeals** and representations. As long as HAKIM X did not provoke a general outcry in the district, they were content to let well alone. Andarabis said HAKIM X **was** in high favour with Baghlan because he delivered more "private revenue" to the GOVERNOR than other deputy commissioners, but I could form no opinion on this.

Andarabis said that HAKIM X was autocratic, extortionate, arbitrary; he treated people high-handedly, with a bad demeanour and grasping severity; he was no Muslim but an infidel through and through. It was certainly true that the scale of mulcts was raised during his period; he was difficult of access; and he did not allow the people sufficient latitude to thrash things out in their own councils. He made his own favourites, deliberately distributing his patronage so as to alter in his own favour the existing network of political alliance within the district; this made him seem "no respecter of persons"—to one half of Andarab. At the same time, everyone acknowledged that he was a "manly man", firm and decisive. His judgments did not waver; one could rest assured that whatever he decided was definitively settled, once and for all. At least everyone knew where effective authority lay.

In contrast to HAKIM X, his successor, HAKIM XI, a young graduate from Kabul, set out to be a bureaucrat rather than an autocrat. He came armed with good intentions, and copies of the relevant statutory and administrative codes. He certainly ran his own department well, but failed to maintain a tight enough rein on the other departments. The COMMANDANT OF GENDARMERIE particularly became a little hākim on his own; every secretariat official, clerk and gendarme had his own opinion and tended to go his own way. This "decentralization" was not to the ordinary petitioners' advantage. HAKIM XI was easy enough of access—and the number of petitions brought before him increased—but no one could be sure how long the other departments would keep the matter pending, and whose recommendation would finally decide the issue. The number of counterpetitions, and appellate approaches to Pul-i Khumri and Baghlan also increased. The confusion of authority within the secretariat gave ready opportunity to Andarabis of political tastes to work out their own rivalries through administrative meddling and middle-manship.

A few months after he arrived, HAKIM XI was obliged to submit a secret memorandum to the GOVERNOR, in which he named certain individuals "who frequented teashops and spent their time manufacturing petitions"; he recommended their removal from Andarab, and said they should be replaced by

Afghans brought in from elsewhere. The GOVERNOR was not willing, naturally enough, to go to any such lengths, considering that the matter was an endemic disease of which any deputy commissioner should know the remedy. Moreover, the GOVERNOR had already heard that HAKIM XI could scarcely control his own subordinates, let alone the litigious Andarabis.

HAKIM XI's real failure lay in not being master of his own house, and in allowing the initiative to pass to others both within and without the secretariat. He seemed to think that the work of government could be implemented directly, by-passing the middle-men. For instance, I once observed him address the multitude in Deh Salah on bazaar day, to the effect that they should bring their petitions to him personally, without the intermediation of village headmen and others. He also said that no one need stir unless the gendarme's summons was signed by himself, an announcement of procedure intended to curb the independence~~ly~~ enjoyed by the COMMANDANT OF GENDARMERIE. A few minutes afterwards, when two revenues department clerks, and the gendarmes on summons, asked what he wanted done about certain arrears to be collected and the road mending operations, HAKIM XI immediately said, "Get the respective village headmen at once; hold them personally responsible." Similarly, when the GOVERNOR wanted to build a public mosque in Baghlan and called for the DEPUTY

COMMISSIONERS to levy the Khans and entrepreneurs in their districts for the purpose, HAKIM XI had great trouble in securing compliance from the Andarabis. The administrative codes could not tell him how to distribute the burden, much less how to realise the moneys expeditiously.

HAKIM XI once said to me, "There is security and peace in Andarab; abductions, murder and theft do not occur; the national service conscripts and the grain levy have been delivered; in six months 90,000 afghanis of revenues in arrears have been collected; the livestock tax is as ever; the 'tithe' costs of civil litigation realised have been increased by 7,000 afghanis. What more do they want? Let them complain that I am lax. What they mean is that they do not get their cut, as they did last year, when officialdom and its courtiers grew fat upon the poor. I will not mulct the people any more; the Day of Judgment is very hard to contemplate." This statement may be accepted as a fair summary, except that, as HAKIM XI ruefully admitted, he could not mend every other official to equal moderation and rectitude, nor prevent certain Andarabi big-wigs from having crooked and too frequent recourse to the secretariat. It was such people who complained of HAKIM XI's levity, incompetence and unmanliness; the common citizenry were satisfied that he was a "good Muslim", who received them well and gave each a fair hearing.

To sum up: The district's order and rule are entrusted to a score of officials and a token garrison of gendarmes, every one of whom is a stranger to the place. Their posting and transfers go on all the time, independently of one another, and no one spends more than two or three years in one district. The minimum duties with which they are charged cannot be carried out without the assistance and intermediation of a great number of local people, village headmen, Khans, Treasurer, Town Clerk, etc. Furthermore, over and above what must be realised for the central exchequer, local officialdom is free, within certain politic limits, to obtain a "private revenue" by a system of mulcts, surcharges and fees of commission. A portion of this finds its way, from each district, to the superior officials of the province. The net result is that all officials quickly become involved in a network of manoeuvre, alliance and intrigue with the native inhabitants. In this process of mutually coming to terms, on their side, the officials can discharge their administrative functions as well as earn the fruits of office; whilst, on the other side, the citizenry are assured of access to authority and a measure of local self-government.

The personal policy of the Deputy Commissioner is the most important single factor which sets the tone of government. He arrives on the scene to find a pre-existing configuration within the total circle of relevance (Fig.13). Whatever particular solution he adopts in coming to terms with it, and

whether or not he takes the initiative in showing favours and taking sides, he cannot but alter existing alignments among the various departments, and between them and the local individuals or factions. Gradually, a new configuration emerges, influenced by the distribution of his patronage and so it goes on.

As regards the combined function of the magistracy and the court, it rests on a system of restitutions. Torts and penal infringements are not sharply distinguished, since the state and the plaintiff (or his successor) are acknowledged to possess claims over the defendant in criminal cases. There are certain cases of breach of administrative law where the state alone has a claim, but these do not go to the Qazi's court at all, being disposed of by the chief executive-cum-magistrate.

It is rather an illusion that Afghanistan appears a highly centralized state; in practice, as one Andarabi said to the Deputy Commissioner, "You are a father to us; our Chief. We cannot reach the Commissioner, the Governor, the Prime Minister; you are all of them to us." On the other hand, the district Chiefs, although allowed a great deal of latitude in administering the law, must exercise strategem as well as force in order to rule. Indeed, the process of government seems to be the outcome of a continual tussle between rulers and ruled, each trying to get the other's measure of the moment, rather than to follow established codes, procedures or precedents.

CHAPTER VI

ISLAM

Islamic law is the typical product of an ethical society.... Once the science and structure of law were established, they not only supplied a rigid frame for the Muslim ideals of ethical duty and human relations, but the law itself, the Sharia, defined once and for all the constitution of the Muslim Community. The Sharia to the Muslim stands for all that the Constitution stands for to the United States of America and more. It established norms for all Muslim institutions and societies, which have ever since remained the sheet-anchor of Muslim culture... ; it expressed and went far to creating a united Muslim community, in spite of political fragmentation and conflict; and it is still, notwithstanding all the criticisms of Muslim modernists and reformers, the sole embodiment of what would otherwise be a merely formal unity of faith among all Muslims.¹

There is no doubt that Andarabis are orthodox, full-blooded, even fanatical, Muslims. They view the Islamic code holistically, as something which enters into all departments of their life, without distinguishing the sacred from the profane. Moreover, as the above passage would suggest, adherence to Islam serves to bind them not merely to one another, and to the neighbouring communities within the Afghan kingdom, but to the inclusive and cosmopolitan fraternity of the faithful in all quarters of the world. In so far as Muslim faith and practice are not wholly

1 H. A. R. Gibb, Studies on the Civilization of Islam (London, 1962), pp. 198-200.

uniform or static, it is necessary to add that the Andarab community represents a segment of medieval Muslim civilization, before the rise of the Sufi movement. Islam in Andarab is an austere and stern system, eschewing mysticism, and free from the cult of saints. The Muslim devotional orders are not represented there.

There are no sacraments and no ordained priesthood in Islam. Yet there are rituals and acts of devotion, prescribed by the Koran, whose observance is the external sign of membership of the Muslim community; and there is a body of mullahs, learned in the sacred texts and law, who may be referred to as the religious establishment. It is with these aspects of Islam that we are concerned in this chapter. The individual mullah's first duty is to act as the officiating prayer leader (imām) of a particular mosque, but collectively the mullahs are also a body of legists, interpreters and upholders of the Islamic constitution ('ulema) in all its manifestations. We shall consider their role in Andarab in both these capacities.

1. The rites of Muslimhood

The mosques of Andarab are simple structures, lacking domes or minarets. The biggest of them, in Banu, can hold an assembly of three hundred or so worshippers; but all mosques are situated within a courtyard or garden, or near some other open space, so that a large congregation can be

accommodated. The bigger mosques are usually associated with the madrasas, or little seminaries, taught by the particularly learned maulavis, who are the leaders of the religious establishment of the district.¹ These bigger mosques serve a group of villages as their Friday or congregational mosques (masjid-i jāmi'). The large qal'ahs of the Khans, which are often set apart from the village settlement, invariably have a small mosque room, used for the daily prayers, which is built as a part of the guest and reception portion, not the dwelling-house. The Khan may himself maintain a mullah, or a younger son of his may give the call to prayer. As one mosque must not be closer than two hundred paces to the next, a surfeit of places of worship is discouraged. A village section has never more than one mosque, although two village sections may share their mosque and mullah. Village mosques are built communally, and used communally for the daily ritual; they are also used to hold other assemblies, to receive passing travellers and guests, etc. They are a purely male precinct; no female beyond the status of child ever sets foot in one—although her marriage might be contracted there.²

1 See pp. 51-52, and Fig. 3.

2 The final seal of marriage is the verbal acceptance of the match and its material consideration by the girl's marriage guardian, and his relinquishment thereby of the office of guardianship, in the presence of witnesses. The mullah then recites a short prayer, which is echoed by the congregation. The groom and his marriage guardian are present, but never the girl, whether the ceremony occurs in the mosque or some other place in her village section.

The village section's mullah is on contract to his congregation; this contract is often written, signed or sealed by the "five greybeards" of the place, and reviewed annually. It specifies the amount of grain (wheat, unhusked rice and barley) which he is to receive in one year as his salary for being the settlement's mosque prayer leader. If he is unmarried and does not belong to the village as a native, the mullah is fed by the different households in turn; he sleeps in the mosque or in someone's guest-room, and may be given a bedding roll as part of his contract.

A mullah has some further income apart from the maintenance contracted for by his congregation. In the first place, he stands in as the recipient on those periodic occasions when Muslims are required to pay religious tax (zakāt) or make legal almsgiving (khairāt). Thus, once a year, all members of the congregation make over to him:

(a) a small amount in cash, one sēr of wheat and one of salt, as zakāt; (b) one basketful of grain at harvest time as haq-al-Allah, that which is due to God; (c) one quarter sēr grain per head of the household at the termination of the fasting month (Ramazān), when the feast of breaking the fast (Īd-i Ramazān) must be preceded by legal almsgiving; (d) a portion of the beast of sacrifice, which must be similarly set aside for the poor, at the second great annual festival of Islam (Īd-i Qurbān, the feast of sacrifice), held at the

end of the period fixed for the pilgrimage to Mecca.

Secondly, the mullahs of the village, and also from further afield, are called in when an adult dies, and are given the khairāt alms in cash or kind. A great concourse of mourners are given a feast when a great man dies, but the mullahs alone receive the alms payments.

Thirdly, there is widespread belief in malignant jinn, the evil-eye, etc., and a mullah is paid to perform certain services for individuals to ward off these influences. He writes all manner of charms and talismans, which are worn universally by children as a protection against disease, and by adults for a variety of ends.

The mullah leads his congregation in ritual worship in the mosque at the five stated times daily: (1) at dawn or just before sunrise; (2) just after midday; (3) midway between the preceding and the following, but allowable until before sunset; (4) just after sunset; (5) when the night has closed in. The prayers may be performed anywhere, and singly or in company, but it is more meritorious if they are performed as a congregation, behind a prayer leader, and better still in a mosque. The mosques are usually well attended for the periods (1), (2) and (4), which are more accurately fixed than periods (3) and (5) where the exact time of performance is allowed a certain latitude. The ritual worship (namāz) is preceded by prescribed ablutions and abstersions, connected

with removing bodily pollutions. The ritual consists of a set of prescribed ejaculations, recital of parts of the Koran, accompanied by prostrations of the body, detailed physical positions being prescribed for each part. The congregation punctiliously coordinate their recitations and genuflexions, exactly following the movements of the prayer leader; all face towards Mecca. It is not necessary that the prayer leader must be a mullah; anyone who knows the liturgical formularies (all in Arabic) may lead.

Once a week, on Fridays, the midday prayer is said in the congregational mosques (masjid-i jāmi'), at which people from a number of villages gather. It includes a special bidding prayer (khutba) in which the King's name is mentioned, and which is preceded by a sermon or declamation (in Persian). It is the ideal that all the borough should come together as one congregation during the two annual Īd prayers, but as this is not practicable, the prayers are held at a number of points (Kishanabad, Banu, Sangburan, Deh Salah, Tal-i Mir Ghazi, Dehak), each of which collects the concourse from its particular hinterland. The "greatest" maulavis of Andarab lead these congregations. At the Īd-i Qurbān (the feast of sacrifice after the Meccan pilgrimage) the Deputy Commissioner reads out to the Banu congregation a message from the King.

Every mullah is an educator to some extent. It is he, even more than the child's parents, who teaches the little boys and girls of the village the Koranic passages which they

must learn by heart in Arabic as the necessary recitations for their future prayers. He teaches them, also by catechetical rote, that they are the servants of God; the children of Adam; of the community of Muhammad the law-giver; and of the "rite" or school of the Great Imam (Abu Hanifa). He teaches them the six foundations of faith (doctrine), i.e. belief in: the unity of God; Angels; the divinely inspired Books; the Prophets; the Judgment Day; and the Decrees of God. He teaches them the five pillars of Islam (practice): shahadah, bearing witness that there is no deity but God, and Muhammad is His Apostle; namāz, observance of the five stated periods of prayer; zakāt, giving the legal alms once a year; rozah, fasting during the (daylight hours of) whole month of Ramazan; hajj, making the pilgrimage to Mecca once in a lifetime. He teaches them to abhor pork and wine-bibbing, to respect their parents and elders, etc., etc.

The mullah is privileged to enter the domestic precinct on certain occasions. When a child is born, the mullah is called in to whisper the required short formulary into its ear, which makes it a Muslim child. When a person is thought to be approaching death, again the mullah comes to keep vigil and recite the Koranic passages, both for their value of healing and so that the individual may pass from this life in a state of grace as a Muslim. This is done for men as well women, the mullah being considered on those occasions as a

mahram, non-marriageable person, from whom the woman is not in purdah.

Although male circumcision is universally practised, at some time before the boy's seventh year, the mullah is not required at it. The operation is performed simply by the barber.¹ A boy is thought to have attained religious majority when he can join in the mosque prayers and can keep the fast of Ramazan for the whole month. Women also perform the daily ritual prayers (but singly—as against in congregation,—and at home), and keep the fast, but their social maturity is recognized by the withdrawal into seclusion at some time before puberty. They do not emerge to join any public congregation after that. E.g., although the funeral rites for a man or a woman are the same, and a woman is buried in the same graveyard, women do not accompany the funeral procession, but meet in the deceased's domestic quarters for the mourning.

The most general way in which I can summarize the total function of the religious establishment is to quote the Andarabi saying that "The Book is with the mullahs; the people are as the blind. The mullahs must propogate [the Book] among them." It is largely through the steady propogation of the Islamic way by the mullahs and the maulavis, centered in their little

1 P. 42 above.

seminaries supported by the people,¹ that Andarab today resembles a segment of medieval Muslim civilization, and other customs have been eradicated or pushed into the background. The mullahs still constantly apply, to a very wide field of customary acts and dealings, the five degree scale of ethico-religious values developed in classical Islam (obligatory, farz/ commended, sunnat/ permissible, mubah/ disapproved, makruh/ forbidden, harām), and the parallel but more properly legal concepts of valid (rawā)/ invalid (nārawā).² No department of behaviour is free from the characteristic stamp of Islam—from the regulations of inheritance and marriage, the forms of commercial dealing, the slaughtering of animals, the prohibition of music (even the call to prayer must have all melody removed from it), down to the minutest details of dress, deportment and salutations. This is not to say either that the social structure of Andarab can be deduced from a compendium of the Islamic code,³ or even that the Andarabis are a particularly priest-ridden community. (They have a proverb, "It is easy to become a mullah, but not to become a human being.") What it does mean is that the people derive their deepest collective pride from adherence to Islam, and regard Muslimhood as the source and fountainhead of their individual

1 See pp. 51-52 above.

2 Cf J. Shacht, Introduction to Islamic Law (Oxford, 1964), pp. 120-121, 200-201.

3 E.g., see pp. 109 f., above.

existence as citizens and civilized beings. Their conception of citizenship, its rights and obligations, springs not from their incorporation as individuals within the Afghan state, but from membership of the cosmopolitan Muslim community, which stands forever contrasted with jāhilīyat, "the pagan (barbarian) condition (of the Arabs) before the advent of Islam".

Initiation into the community of Muhammad is achieved, sustained and constantly renewed, from day to day and year to year. The main rites through which this is done are those of the ritual worship (namāz), fasting (rozah), and pilgrimage (hajj). I do not enter into the form and function of these rites, but mention below some points which are of particular relevance to Andarab.

Perhaps the first thing to notice about some of the rites is their timing. The fasting month, Ramazan, which involves abstinence from all food, drink, smoking and sexual relations, is fixed according to the Arabic lunar calendar, and so rotates throughout the year.¹ It is strictly kept in Andarab, and can cause great hardship when it falls in the summer, and agricultural and other work has to be carried on

1 The Afghan Persian calendar and the Arabic calendar both commence with the date of the Hegira, the flight of Muhammad from Mecca to Medina; but the Afghan Persian calendar (in use in Andarab) follows the solar year.

Ramazan is the name of the ninth month of the Arabic lunar month. The names of the Afghan Persian months are different.

despite the fast. Yet its very rigidity serves at least to synchronize the remotest community's abstentions with those of all others within the inclusive Muslim society.

The period of the Meccan pilgrimage is similarly fixed according to the Arabic months, and the feast of sacrifice (Īd-i Qurbān) is celebrated in Andarab at the end of it, whether or not anyone from Andarab has gone on the pilgrimage (hajj). The number who do go to Mecca from Andarab varies greatly from one year to another: in 1960 some 13 pilgrims went (by air from Kabul, at a total cost of £200 per head), while in 1961 only four went; in former years a Hājji was a rarity. Women are not prohibited from going to Mecca, but no woman from Andarab has ever been.

It should be noted, however, that there are certain lesser pilgrimages, within the reach of poorer Andarabis, which are timed according to their calendar. The first of these is to the shrine at Mazar-i Sharif (Map 1), reputed to contain the remains of Ali, Muhammad's son-in-law and cousin. Here new banners are raised at a ceremony on the 40th day of the Afghan Persian new year; it is called the Red Tulip festival (as it falls in the spring, when these flowers appear) and tens of thousands of pilgrims collect there from all the northern parts of Afghanistan. The second favourite place of pilgrimage is at Hazrat Imam Sahib on the Oxus, within Qataghan province, where the shrine is

that of a grandson of Muhammad. A banner raising also occurs there in the spring. Finally, within Andarab itself, there are several minor shrines (ziyārat), either on the high road or in remote places in the hinterland, which people visit at various times. Two of these, in Sangburan (the grave of a grandson of Ali) and near Saiad, are well kept, and banners are raised there in the spring. People visit these places for the merit of pilgrimage, to seek forgiveness, to be cured of blindness, etc., and for the general blessing of proximity to the shrine of one or other of the great heroes of Islam, who died fighting for the faith. Women visit there also, e.g. to be blessed with a child, but in Andarab they go separately from the men, and are not present when the banners are raised in Saiad or Sangburan. One learned maulavi of Andarab maintains that women must not go there at all; it is unlawful (nārawā).

The most oft-repeated rite of Muslimhood is that of the namāz, the liturgical prayer. That it is a ritual of initiation of the individual into the cosmopolitan Muslim community is manifest from its particular form, which is well known and need not be gone into here. In the distribution of the mosques, minor and masjid-i jāmi', which follow the politico-administrative and territorial units, the collective worship consecrates the congregation of each one of these units as a part of the total territory of Islam (dar-ul-Islām).

In these congregations, whether small, on the daily occasions, or large, on Fridays and the two Īds, there is no precedence in the mosque. Each individual is his own ministrant in these rites, and all are treated strictly equally. The normal divisions and distinctions within the local community, whether based on socio-economic criteria, kinship, age, and the separation of household groups, are all set aside. Such divisions and distinctions, which are normally expressed in terms of precedence in seating in assembly are "scrambled", so to speak, when the individual citizens of the locality congregate to perform the rites of Muslimhood at the stated periods. In the same way, the period of entering the state of special grace during the fasting month, may be said to "scramble" the seasonal cycles which regulate agricultural and pastoral activities.

The periodic congregational rites and the seclusion of women are the two most highly and systematically ritualized aspects of life in Andarab. Although both of them are equally enjoined by Islam, yet they stand at right angles, as it were, to one another; the one representing the universalist face of the community and the other its particularist face. For the seclusion of women is not merely a system of the separation of the sexes; the limits of purdah define for the "full" citizens, the adult males, the limits of personal kinship and domestic access. These are particular to

each individual male, and concerned with the range of his ego-centric interests. The congregational rites which remove him from his own household, and from womankind in general, represent the universalist warp laid across, and interwoven with, the particularist woof in the total web of interrelations which constitutes the local community. The women are not excluded from the congregational rites because they represent the profane or the polluting; they also perform the namāz and keep the fast. But they are "junior" or "private" citizens only, confined to the domestic as against the public realm, and made to symbolize the particularist as against the universal. The conjugal relationship, because of its very nature in representing the separateness and jealous honour of the householder, must be left behind when men go to the mosque to become brothers in equal humility before God.

BIBLIOGRAPHY OF REFERENCES CITED

- Ameer Ali, S., Personal Law of the Muhammadans. Calcutta, 1880.
- Barthold, W., Turkestan down to the Mongol Invasion.
London, 1928.
- Beal, Samuel, Chinese Accounts of India: Translated from
Hiuen Tsiang. 4 vols. Calcutta, 1957-8 ed.
- Elphinstone, Mountstuart, An Account of the Kingdom of Caubul.
London, 1815.
- Fyzee, A.A.A., Outlines of Muhammadan Law. Oxford, 1949.
- Gibb, H.A.R., Studies on the Civilization of Islam.
London, 1962.
- Holdich, Sir Thomas, The Gates of India. London, 1910.
- Hughes, T. P., Dictionary of Islam, London, 1885.
- Ibn Battuta, Travels in Asia and Africa, trans. H.A.R. Gibb,
London, 1928.
- Julien, Stanislas, Le vie de Hiouen-Thsang. Paris, 1853.
- Kushkaki, Burhannudin, Rahnumā-i Qataghan va Badakhshān.
Kabul, 1925.
- Le Strange, Guy, Lands of the Eastern Caliphate. Cambridge,
1905.
- Levy, Reuben, The Social Structure of Islam. Cambridge, 1957.
- Minorsky, V., trans., Hudūd al-'Ālam. London, 1937.
- Prasad, Ishwari, Life and Times of Humayun. Calcutta, 1956.
- Robertson, George S., The Kafirs of the Hindu Kush. London,
1896.
- Schacht, J., An Introduction to Islamic Law. Oxford, 1964.
- Schurmann, H. F., The Mongols of Afghanistan. The Hague, 1962.
- Sultan Mahomed Khan, Mir Munshi, ed., Life of Abdur Rahman.
London, 1900.

- Tarn, W. W., Alexander the Great. Cambridge, 1948.
- Vambery, A., Travels and Adventures of the Turkish Admiral Sidi Ali Reis during 1553-1556. London, 1899.
- Watters, Thomas, On Yuan Chwang's Travels in India. 2 vols. London, 1904.
- Wheeler, Stephen, The Ameer Abdur Rahman. London, 1895.
- Wilber, D. N., ed., Afghanistan. New Haven, Conn., 1956.