

PACIFIC LINGUISTICS

*Series C* – No. 48

PAMPANGAN:  
TOWARDS A MEANING-BASED DESCRIPTION

by

Andrew Gonzalez



Department of Linguistics

Research School of Pacific Studies

THE AUSTRALIAN NATIONAL UNIVERSITY

PACIFIC LINGUISTICS is issued through the *Linguistic Circle of Canberra* and consists of four series:

- SERIES A - OCCASIONAL PAPERS
- SERIES B - MONOGRAPHS
- SERIES C - BOOKS
- SERIES D - SPECIAL PUBLICATIONS

EDITOR: S.A. Wurm.

ASSOCIATE EDITORS: D.C. Laycock, C.L. Voorhoeve, D.T. Tryon, T.E. Dutton.

EDITORIAL ADVISERS:

- |   |   |
|---|---|
| B. Bender, University of Hawaii                 | K.A. McElhanon, University of Texas   |
| D. Bradley, University of Melbourne             | H. McKaughan, University of Hawaii  |
| A. Capell, University of Sydney                 | P. Mühlhäusler, Linacre College, Oxford   |
| S. Elbert, University of Hawaii                 | G.N. O'Grady, University of Victoria,<br>B.C.   |
| K. Franklin, Summer Institute of<br>Linguistics | A.K. Pawley, University of Hawaii   |
| W.W. Glover, Summer Institute of<br>Linguistics | K. Pike, University of Michigan; Summer<br>Institute of Linguistics                           |
| G. Grace, University of Hawaii                  | E.C. Polomé, University of Texas  |
| M.A.K. Halliday, University of Sydney           | G. Sankoff, Université de Montréal  |
| A. Healey, Summer Institute of<br>Linguistics   | W.A.L. Stokhof, National Center for<br>Language Development, Jakarta;<br>University of Leiden |
| L. Hercus, Australian National University       | J.W.M. Verhaar, University of Indonesia,<br>Jakarta   |
| N.D. Liem, University of Hawaii                 |   |
| J. Lynch, University of Papua New Guinea        |   |

ALL CORRESPONDENCE concerning *PACIFIC LINGUISTICS*, including orders and subscriptions, should be addressed to:

The Secretary,  
*PACIFIC LINGUISTICS*,  
Department of Linguistics,  
Research School of Pacific Studies,  
The Australian National University,

Canberra, A.C.T. 2600.  
Australia.

Copyright © The Author  
First published 1981.

The editors are indebted to the Australian National University for help in the production of this series.

This publication was made possible by an initial grant from the Hunter Douglas Fund.

National Library of Australia Card Number and ISBN 0 85883 244 5

## FOREWORD

Originally a doctoral dissertation presented to the Department of Linguistics of the University of California at Berkeley, this study of the Pampangan language using Chafe's generative semantic model was completed in September 1970.

The dissertation was done under the direction of Professor Wallace L. Chafe, who served as Chairman of the Dissertation Committee, with Professors Denzel Carr and Karl E. Zimmer as members.

Other than updating the census figures for Pampangan and making minor corrections, I have made no other changes in this published version. I find that even after a decade, I would change little in the description. It is my hope that students of Pampangan and the Philippine languages will find in a meaning-based model a source of rich insight into the language.

I am deeply grateful to the Linguistics Department, Research School of Pacific Studies, of the Australian National University at Canberra for making this publication possible under its Pacific Linguistics series and to Judy Wise for her work in seeing the manuscript to publication.

De La Salle University  
Manila, Philippines  
1980

Andrew Gonzalez, FSC



## TABLE OF CONTENTS

	<i>Page</i>
FOREWORD	iii
MAP 1 - THE PHILIPPINES SHOWING LOCATION OF PAMPANGA	xii
MAP 2 - PAMPANGAN LANGUAGE AREA	xiii
INTRODUCTION	1
0.1. Preliminary Notes	1
0.1.1. General Information	1
0.1.2. Pampangan and the Other Philippine Languages	1
0.2. Review of Scholarship	2
0.2.1. Pampangan in Comparative Studies	2
0.2.2. Pampangan in Descriptive Studies	3
0.2.3. Recent Descriptive Studies in Pampangan	5
0.2.4. Sources for the Study	5
0.3. The Model for Analysis	7
0.4. Scope, Limitations, and Purposes of the Study	9
0.5. Plan of the Study	11
NOTES	12
CHAPTER I: SEMANTIC PROCESSES	13
1. INTRODUCTION	13
1.1. SPECIFYING V	17
1.1.1. State Verbs	17
1.1.2. Process Verbs	28
1.1.3. Action Verbs	31
1.1.4. Process-Action Verbs	41
1.1.5. Other Verb Specifications	45

	<i>Page</i>
1.1.6. Summary of $\overline{V}$ N Relations and Re-statement of Rules	47
1.1.7. Verb Derivational Processes	53
1.1.8. Verb Inflectional Units	69
1.1.8.1. State Verb Inflections	70
1.1.8.2. Non-State Verb Inflections: Perseverative, Repetitive, Intermittent	71
1.1.8.3. Verb Inflectional Units: Aspect	73
1.1.8.4. Verb Inflectional Units: Negative	77
1.2. SPECIFYING N	78
1.2.1. Selectional Units	78
1.2.2. Noun Derivational Processes	86
1.2.3. Noun Inflectional Units	99
1.2.4. Classifiers	109
1.3. NEW/-NEW INFORMATION	116
1.4. TOPIC	120
1.5. SUMMARY	124
FIGURE 1	66
FIGURE 2	68
FIGURE 3	96
FIGURE 4	97
 CHAPTER II: POST-SEMANTIC PROCESSES	 127
2. INTRODUCTION	127
2.1. SUBJECTIVISATION	128
2.1.1. Subjectless Sentences	129
2.1.2. Subjectivised Sentences	130
2.1.2.1. All-New Sentences	130
2.1.2.2. Sentences with -New N's	135
2.1.2.3. Extra-position Rules	137
2.1.3. Subjectivisation Rule	140
2.1.4. Subject Incorporation into V	140
2.1.5. Subjectivisation in the Scholarly Literature on the Philippine Languages	141
2.2. SYNCRETISATION	143
2.3. OBLIQUE/-OBLIQUE SPECIFICATION SHIFTS	146
2.3.1. Shift: N           to N OBLIQUE       -OBLIQUE	
2.3.2. Shift: N           to N -OBLIQUE       OBLIQUE	



	<i>Page</i>
2.7. LINEARISATIONS	196
2.7.1. Major Processes	196
2.7.1.1. Primary Linearisation	197
2.7.1.2. Post-Posing	198
2.7.1.3. Pre-Posing	199
2.7.1.4. Sentential Accent in Pampangan	201
2.7.2. Minor Linearisation Processes	203
2.7.2.1. Linearisation of V	204
2.7.2.2. Linearisation of N	210
2.8. SUMMARY	217
2.8.1. Re-statement of Rules	217
2.8.2. Post-semantic Derivation of a Pampangan Sentence	231
TABLE 1	182
TABLE 2	214/5
 CHAPTER III: MULTIPLE V's IN SEMANTIC STRUCTURES	 237
3. INTRODUCTION	237
3.1. $\overbrace{V \quad V}$ CONFIGURATIONS OF EQUAL RANK	238
3.1.1. Explicit Linking	238
3.1.1.1. Conjunctive	238
3.1.1.2. Adversative	239
3.1.1.3. Supererogative	239
3.1.1.4. Purposive	240
3.1.1.5. Resultative	241
3.1.1.6. Concessive	241
3.1.1.7. Disjunctive	242
3.1.1.8. Conditional	245
3.1.1.9. Summary	247
3.1.2. Implicit Linking	247
3.1.2.1. Additive	248
3.1.2.2. Iterative	249
3.1.2.3. Seriative	250
3.1.2.4. Subitive	251
3.1.2.5. Solitive	252
3.1.2.6. Precedent	253
3.1.2.7. Caditive	253
3.1.2.8. Explanative	254
3.1.2.9. Summary	254

	<i>Page</i>
3.2. $\overbrace{V \quad V}$ CONFIGURATIONS OF UNEQUAL RANK	256
3.2.1. $\overbrace{V \quad \overbrace{V \quad N}}$ Configurations	257
3.2.1.1. Manner Adverbs	257
3.2.1.2. Frequency and Instance Verbs	259
3.2.2. $\overbrace{V \quad V \quad N}$ Configurations	260
3.2.2.1. Sentential Adverbs	260
3.2.2.1.1. Commentative, Validative, Certainitive, Necessitative, Frequentative	260
3.2.2.1.2. Adverbial Phrases of Place, Time, Benefaction, and Motivation	263
3.2.2.1.2.1. Locative	263
3.2.2.1.2.2. Temporal	266
3.2.2.1.2.3. Benefactive	275
3.2.2.1.2.4. Motivative	278
3.2.2.1.2.5. Integrating Subjectivisation	280
3.2.2.2. Other Structures	281
3.2.2.2.1. Embeddings in V experiential	282
3.2.2.2.2. Embeddings in V action completable	284
3.2.2.2.3. Embeddings in V action verbal competable	286
3.2.2.3. Nominalisation	288
3.2.3. Relativisation	293
3.2.3.1. Restrictive Clauses	293
3.2.3.1.1. Relative Clauses with State V	293
3.2.3.1.2. Relative Clauses with Non-State V	296
3.2.3.1.3. Relative Clauses in Generic Statements	298
3.2.3.2. Non-Restrictive Clauses	299
3.2.3.3. Deletion of Root in N's with Relative Clauses	301
3.2.4. Summary	302
3.3. ILLUSTRATION	303
CHAPTER IV: PRE-SEMANTIC STRUCTURES	307
4. INTRODUCTION: THEORETICAL FRAMEWORK	307
4.1. SOCIAL MARKERS	309
4.1.1. Respectful	309
4.1.2. Familiar	313

	<i>Page</i>
4.2. EXPRESSIVE FUNCTIONS	313
4.2.1. V** : Apparentive, Informative, Questive, state Super-prehensive experiential	314
4.2.2. V** action	315
4.2.2.1. V** : Ratiocinative and Velleitive action psychological	315
4.2.2.1.1. Ratiocinative: Inferential	315
4.2.2.1.2. Velleitive: Purposive and Optative	316
4.2.2.2. V** : Exclamative, Concurive, Demurrant action verbal	317
4.3. CONATIVE FUNCTIONS	319
4.3.1. V** : Imperative and Precative action verbal conative	319
4.3.1.1. Commands	319
4.3.1.2. Requests	319
4.3.2. V** action	321
4.3.2.1. V** : Fiduciative, Pretensive, Suppositive action psychological	322
4.3.2.2. V** : Interrogative action verbal	323
4.3.2.3. V** : Selective, Confirmative, Echoic, action Re-assurative, Concurive verbal	345
4.4. SUMMARY	353
4.4.1. Re-statement of Rules	354
4.4.2. Exemplification	358
CHAPTER V: REVIEW AND PREVIEW	367
5. INTRODUCTION	367
5.1. GENERAL CONCLUSIONS	367
5.2. PROBLEMATIC QUESTIONS	371
5.3. REVIEW OF SCHOLARSHIP	375
5.3.1. Bergaño	376
5.3.2. Castrillo	377
5.3.3. Lopez	378
5.3.4. Constantino	380

	<i>Page</i>
5.4. AREAS FOR FUTURE RESEARCH	388
BIBLIOGRAPHY	391

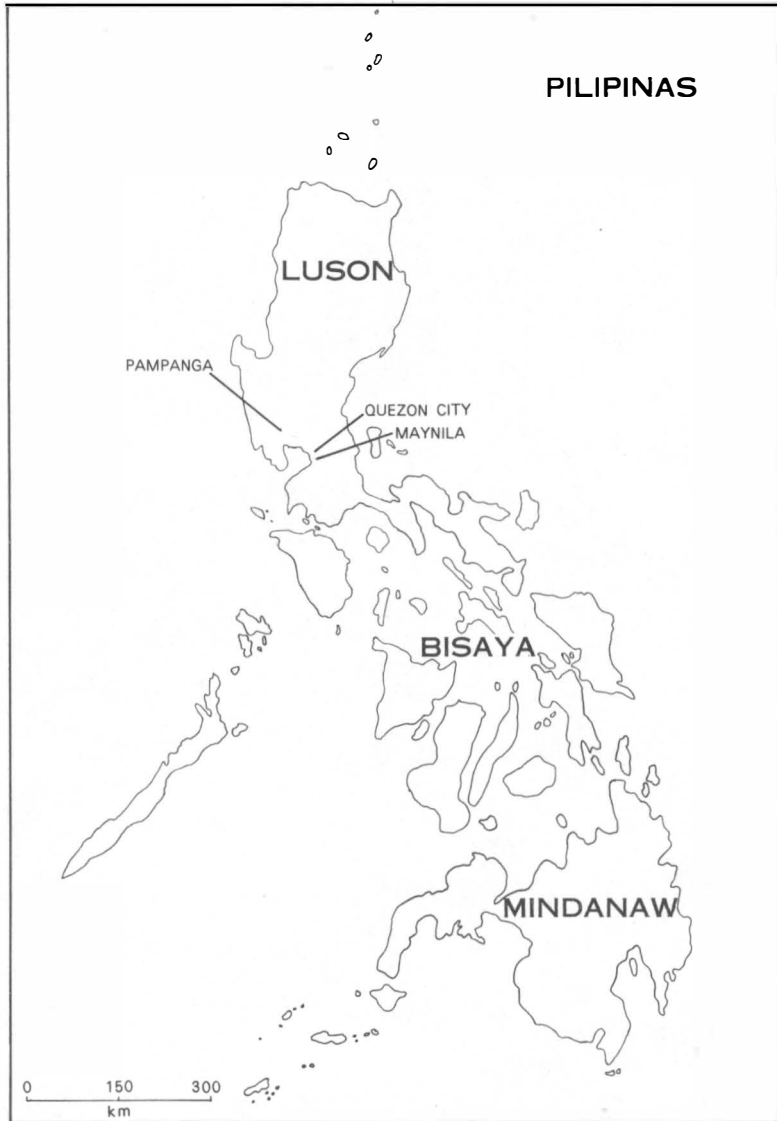

THE PHILIPPINES SHOWING LOCATION OF PAMPANGA

MAP 1

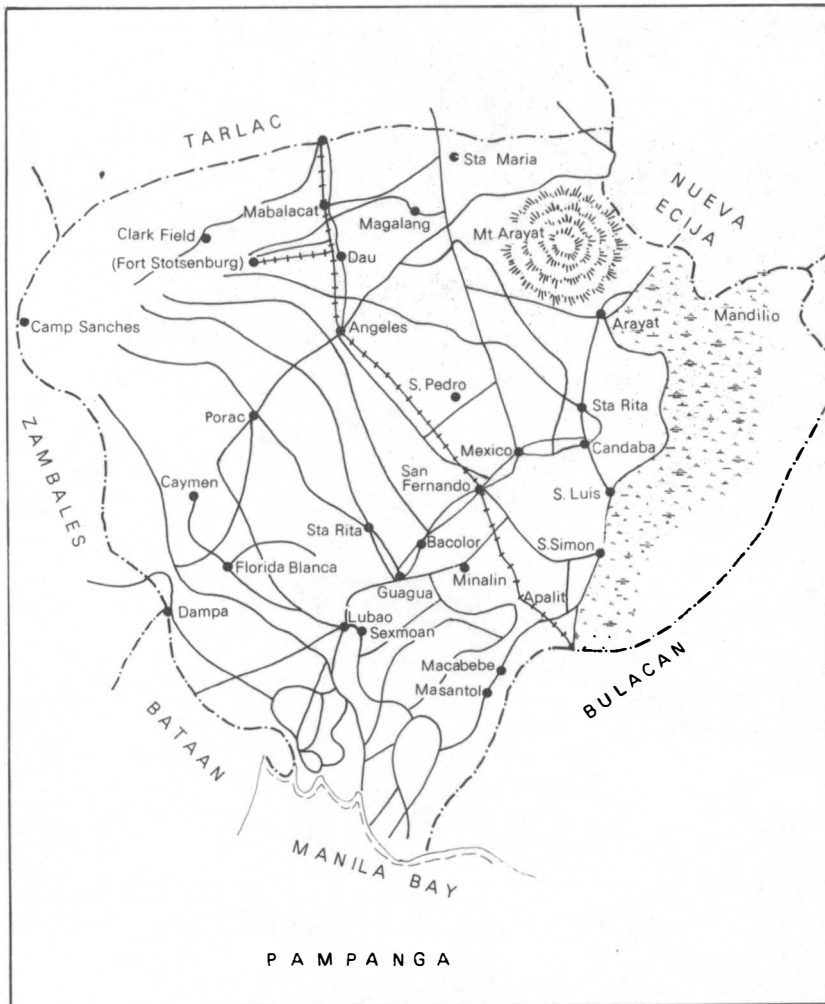

PAMPANGAN LANGUAGE AREA

MAP 2



## INTRODUCTION

### 0.1. PRELIMINARY NOTES

#### 0.1.1. GENERAL INFORMATION

Pampangan (Pampango, Kapampangan: from \*paŋpaŋ 'aus einander stehen' (Dempwolff 1938), Tagalog reflex paŋpaŋ 'Mundung' and Pampangan reflex pampaŋ 'river bank shore'; the name is undoubtedly due to the Pampanga River) is a Philippine language spoken by inhabitants of the provinces of Pampanga and of Tarlac and of the areas in the provinces of Bulacan, Nueva Ecija, Zambales, and Bataan bordering on Pampanga (see Map 2) on the island of Luzon in the Philippines. The 1975 census of the Philippines lists Pampangan as having 1,442,607 speakers.

#### 0.1.2. PAMPANGAN AND THE OTHER PHILIPPINE LANGUAGES

Pampangan belongs to the Central Luzon group of languages (see Map 1), one of the five language groups proposed by Kroeber (1919), who grouped the Philippine languages into five geographical divisions: North-eastern Luzon, North-western Luzon, North Central, Central, and Mindanao.

Lopez (in Thompson 1953:36) would group Pampangan (and Pangasinan) into a non-related cluster apart from three other groups: Northern, Central, and Southern.

The above groupings are based on general inspection of different features of the Philippine languages.

Other groupings, based on vocabulary comparison, have been proposed by Conklin (1951, 1952), Chrétien (1962), Thomas and Healey (1962), and Dyen (1965). Conklin used non-statistical techniques of matching vocabulary, while Chrétien devised a Co-efficient of Similarity after surveying almost two thousand cognate groups of lexical items. Thomas

and Healey and Dyen worked on modified Swadesh lists and based their groupings on lexicostatistical indices.

Conklin (in Voegelin 1952:90-4) categorises Pampangan under his 'non-committal' group, the members of which are not clearly classifiable under either the Iloko-type languages (north) or the Tagalog-type languages (Central).

Chrétien posits a Luzon sequence, with Pampangan as a member of the series in a north-to-south sequence.

Thomas and Healey group Tagalog and Pampangan within the same subset, this subset being a member of a larger subset, the Southern Group of the Philippine Stock.

Dyen (1965:30) places Pampangan as a member of the Sulic Hesion (subordinate to the Philippine Hesion). In turn, the Philippine Hesion is subordinate to the Hesperonesian Linkage. Under the Sulic Hesion, Pampangan is co-ordinate with languages of the Mesophilippine Hesion (which include languages of the Tagalic Hesion), the Dibabaon Sub-family, Kalamian, the Palawanic Sub-family, the Bukidnon Sub-family, and Cotabato Manobo. Pampangan is described as closest to the Tagalic Hesion, more specifically, to Cuyunon of the Bisayan Cluster, with which it shares a vocabulary percentage of 39.2%.

Using phonological criteria, innovations on Dempwolff's Uraustro-nesisch, Gonzalez (1969) places Pampangan as a transitional language between the Northern Group and the Southern groups. Pampangan shares certain phonological features in common with Pangasinan and Sambal, likewise transitional languages.

## 0.2. REVIEW OF SCHOLARSHIP

The scholarly literature on Pampangan is rather meagre (for bibliographical surveys of Philippine linguistics prior to 1920, the date of Blake's bibliography, see Blumentritt 1882, Barrantes 1889, Pardo de Tavera 1903; for a study of the holdings of the Newberry Library on Philippine Linguistics, see Welsh 1950 and Phelan 1955).<sup>1</sup>

### 0.2.1. Pampangan in Comparative Studies

Comparative work on Pampangan has been confined for the most part to vocabulary studies. Johann Reinhold Forster (1778), a member of Captain Cook's second expedition, includes a list of forty-seven lexical items in *Observations faites, pendant le second voyage de M. Cook, dans l'hémisphère austral*. There is a list of two hundred Pampangan lexical items in Pallas's *Vocabularium Catharinae* (1787-1789). Other vocabulary lists may be found in Meyer (1878), Lacouperie (1887), and Kern (1890).

Grammatical features of Pampangan are considered in Blake's studies on Philippine comparative grammar (1906, 1907, 1910, 1916). Lopez (1965) published a survey of syntactic features of twelve Philippine languages, among them, Pampangan, while Constantino (1965), using a transformational model, surveyed the sentence patterns of twenty-six Philippine languages, again, among them, Pampangan.

#### 0.2.2. Pampangan in Descriptive Studies

The first scholars of Pampangan, as in so many of the other Philippine languages, were the Spanish missionaries, who arrived with the conquistadores in 1521 and in 1565; the latter date is the year of actual Spanish settlement in the islands. In keeping with their ultimate purpose of evangelisation, however, the missionaries published pedagogical grammars rather than theoretical descriptions.

The first recorded pedagogical grammar is D. Ochoa's 'Arte, Vocabulario, y Confesionario Pampango', a manuscript in three volumes completed circa 1580 (Blake 1920:65).

Another manuscript, in two volumes, by Sebastián Moreno, 'Sobre el modo de comprender el idioma Pampango y su poesia', dating from the same period, is listed by Pardo de Tavera (1903:186), although he doubts its existence. Blake (1920:65) likewise lists 'Modo y forma de leer los caracteres de la lengua Pampanga' by S. Moreno. It is not ascertainable at present whether or not Pardo de Tavera and Blake are referring to the same manuscript.

Francisco Coronel wrote 'Reglas para aprender el idioma Pampango' (Manila [?] 1617). A more complete manuscript 'Arte y reglas de la lengua Pampanga' (1621) as well as a 'Vocabulario Pampango' at one time existed (Blake 1920:64). Apparently, this Arte was subsequently published, for in 1875, a 'reimpresión' appeared in Manila with the title *Catecismo Pampango arte y vocabulario del mismo idioma*, by Francisco Coronel (Barrantes 1889:186). Coronel's work must have been widely circulated among the Augustinian friars, since subsequently, Diego Bergaño refers to Coronel more than once in his own published Arte as 'mi Coronel', taking for granted that his readers were familiar with the work.

Another manuscript, 'Arte y diccionario Pampango', was written by Alvaro de Benavente, who took the manuscript with him to China and died there in 1709. According to Barrantes (1889:171), Bergaño knew of the work, as he referred to it in his 'Advertencia al lector'.<sup>2</sup>

Still another manuscript, in one volume, dated 1710, 'Vocabulario Pampango', by S. Foronda, is mentioned by Blake (1920:64).

The only published grammar from this period (Spanish Regime, 1521-1898) other than Coronel's is Diego Bergaño's (born 1690, died 1747) *Arte de la lengua Pampanga* and his *Vocabulario de la lengua Pampanga en romance*.<sup>3</sup> Bergaño's *Arte* was first published in 1729, emended and republished in 1736. His *Vocabulario* appeared in 1732. Later, a third edition of the *Arte*, based on the 1736 edition (with only orthographic and accentual changes), was published in 1916. The 1732 *Vocabulario* was reprinted in 1860.

Mariano Alafon(t) wrote 'Notas y adiciones al arte Pampango del padre Vergaño' undoubtedly after the publication of Vergaño's grammar; the undated manuscript is listed by Barrantes (1889:170). Alafon(t) likewise wrote (circa 1786) 'Arte de la lengua Española para uso de los naturales de la provincia de la Pampanga' (Blake 1930:62).

A one-volume manuscript dated approximately 1765 and entitled 'Clave para escribir y leer en Pampango' by J. Calleja is listed in Blake (1920:63).

There are two extant manuscripts by Antonio Bravo (born 1833, died 1897) at the Newberry Library entitled 'Cuestiones gramaticales: sus contestaciones' (Candaba, August 10, 1886, 3 pages) and 'Yslas Filipinas cuestionario y vocabulario de la lengua Pampanga dialecto' (Candaba, August 10, 1886, 30 pages). Previously, the same Antonio Bravo had published in 1875 *Vade mecum Filipino ó manual de la conversaci3n Español Pampango* (Blake 1920:34).

Pardo de Tavera (1903) lists an 1875 Manila publication in seventy pages entitled *Capabaluan ampon usuc a matampa caring tabasna t linica etc. Capampangan ning P. Fr. G. Masnou* without annotation (Entry #1650). From the title, freely translatable as *Fitting Knowledge and Instruction in the Design and [?] of Pampangan by Father G. Masnou*, the work appears to have been intended as a prescriptive grammar for the correct usage of Pampangan.

In 1876, E. Fernández published his *Nuevo vocabulario ó manual de conversaciones en Español, Tagalog, Pampango*. This work underwent five editions (First, Binondo 1876; Second, Manila 1882; Third [?] 1887; Fourth, Manila 1896; Fifth, Binondo 1901).

Gavino Dimalanta published his *Vocabulario Pampango-Tagalog-Inglés*, compiled from a Tagalog-Spanish-English vocabulary list by D.E. Fernández (presumably, the same Fernández mentioned previously) and S.G. Calderón. This book is undated and was published in Manila by J. Martínez.

Another dictionary, by Luther Parker, was published in Manila in 1905, *An English-Spanish-Pampango Dictionary*.

Conant (1911) published a study of 'Monosyllabic Roots in Pampango'. In 1915, Magat published *Grammatica qng sabing castila, t Capampangan* 'A Grammar of the Spanish and of the Pampangan Languages'.

### 0.2.3. Recent Descriptive Studies of Pampangan

Castrillo completed a master's thesis in 1955 at the University of the Philippines entitled 'Pampango Syntax', under the direction of Lopez. The analysis, using a taxonomic model in many ways comparable to the tagmemic model, will be evaluated in the final chapter of this study, together with the articles by Lopez and by Constantino.

A doctoral thesis on Pampangan phonology, using the assumptions of phonemic theory, was completed in 1958 at the University of Texas by Clardy, who summarised her findings in a 1959 article in *Phonetica*. Tabasondra (1962) likewise published a study of Pampangan segmental phonemes based on the same theoretical frame of reference.

### 0.2.4. Sources for the Study

Among the earlier studies, I have had access to the following: Bergaño 1916, Bergaño 1860, Bravo 1886a, b, and Dimalanta [?].<sup>4</sup> I have likewise had access to unpublished vocabulary lists compiled by Perez (1964) and by the Institute of National Language in Manila (see Bibliography) and to a small 'pocket dictionary' by Manalili and Tamayo (1964).

For the rest of the data, I have had to act as my own informant, being a native speaker of Pampangan (Apalit dialect). Because of my bilingual background - I grew up in Quezon City, outside of Manila, speaking Pampangan at home and Tagalog outside - there will most likely be instances of idiolectal peculiarities and of language mixture. Such instances must be taken into account in some of my semantic interpretations, especially of those forms in this study which test the full potentialities of the language. In spite of such possible linguistic idiosyncracies arising from bilingualism (and subsequent exposure to Spanish and English), I find surprisingly little difference between my dialect and Bergaño's Bacolor dialect, which dates back to 1736. Nor do I find any but minor differences between my dialect and that of Clardy's Tarlac informant or that of Tabasondra, who worked with a Tarlac dialect, or that of Castrillo's San Fernando and Mexico informants (see Map 2).

Allowing for minor idiolectal peculiarities, especially in cases of polysemy, then, the semantic structures described in this study should be found to be valid for any Pampangan speaker.

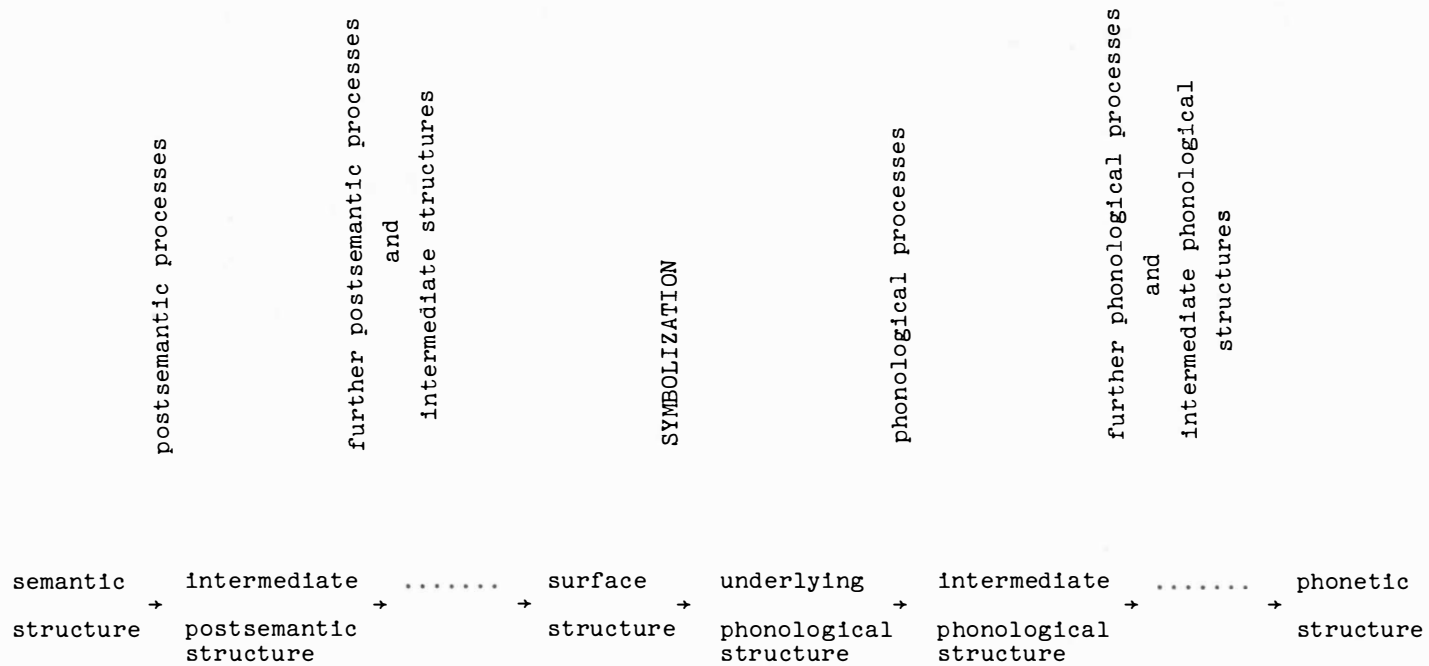

FIGURE 1

(from Chafe 1970b:86)

### 0.3. THE MODEL FOR ANALYSIS

The model to be used for the analysis of the semantic structure of Pampangan is based on Chafe's generative semantic model (1962, 1965, 1967, 1968, 1970a, 1971; the pagination of citations from the last three references is based on the manuscripts of these works and not on the printed versions).

Basically, language is conceived of as symbolisation, a process which connects the content side of language (signifié) with the expression side of language (signifiant). The generation of well-formed linguistic structures takes place initially on the content side of language, where semantic rules of formation generate the components of a well-formed sentence. After configurations of meanings have been assembled by semantic rules of formation, the generated configurations undergo postsemantic processes (comparable in function to the transformations of generative grammar) to yield surface structures. The surface structures are then symbolised by underlying phonological sequences on the expression side of language, which undergo further phonological processes to finally yield phonetic structures (see Figure 1).

The semantic rules of formation consist of specification rules (optional  $\rightarrow\rightarrow$ ; obligatory  $\rightarrow\rightarrow$ ) and of replacement rules (optional  $\rightarrow$ ; obligatory  $\rightarrow$ ) which develop the nucleus of semantic structure, the verb (hereinafter V) or the predicate.

In this theory, V is considered as central, its accompanying nouns (hereinafter N) or arguments as peripheral and as determined by selectional and inflectional restrictions of V.

V is further specified as state, process, action, or process-action; such sub-categories are further specifiable by added selectional units, until the choice of a lexical unit narrows down V to a particular one. In turn, once thus delimited, V is further specified by inflectional units, which are characterised by a lack of relevance to the choice of a lexical unit, insofar as inflectional units may specify any V root.

V's thus developed may be obligatorily or optionally accompanied by role-marked N's (in alphabetical order: agent, agentive beneficiary, associate, beneficiary, complement, experiencer, goal, instrument, location, material, measure, motive, norm, partitive, patient, source, time), thus resulting in  $\overline{V} \quad \overline{N}$  configurations manifesting various semantic relations or axes; rules for stating such co-occurrences are formulated as replacement rules.

N's, like V's, are further specified for selectional units, which narrow down the choice of lexical units, and for inflectional units.

Semantic marking is unary rather than binary, the presence of a semantic unit being indicated by an added marking, its absence unmarked. Where the absence of a unit is a necessary contextual restriction, a minus sign is used to explicitly state the required absence of the unit in question for the rule to apply.

Both V roots and N roots may undergo optional derivational processes, which both add meaning to a root and may change the categorisation or sub-categorisation of a root; for example, under certain storable conditions, an inherent state V may be replaced by a derived abstract N. Such roots, basic or derived, are listed in the lexicon of a language and must be made available for selection in the process of semantic generation.

The well-formed semantic structure generated by the formation rules must then undergo various post-semantic processes to convert the initial semantic structure into a surface structure. Such post-semantic processes typically consist of further specification and replacement rules of transformation, which add, subtract, redistribute semantic and post-semantic units, and finally linearise the semantic structure to yield a linear surface structure. In general, post-semantic processes add no new semantic content to the initial semantic structure. It is a moot question at present whether post-semantic processes do add some new semantic content in certain instances (see Chafe 1970b:108-16; 1971:12).

Chafe's model purports to be a radical departure from the model of 'autonomous syntax' proposed by Chomsky (1965), although Chomsky (1969) considers the model (as proposed in Chafe 1967) as only a notational variant differing from the 'standard theory' only as regards the model's assumptions concerning the directionality of mapping (for an answer to Chomsky, see Chafe 1970b:98-102, 1971:10-4 in particular). It would be outside the scope of this study to evaluate such theoretical claims and counter-claims. It suffices to compare the results of this study of Pampangan structures with the results of analyses of other Philippine languages which have been completed using Chomsky's model to see if any empirical differences arise from the application of the two models; see, for example, Constantino's (1960) study of Iloko; Anderson's (1965) contrastive analysis of Cebuano and English; Otanes' (1966) contrastive study of English and Tagalog complementation; Schacter's and Otanes' (1972) reference grammar of Tagalog.

In its use of V as the nucleus of a sentence, with accompanying role-marked N's, Chafe's model bears a striking resemblance to Fillmore's (1968) Case Grammar, although Fillmore's V and C's (Cases) are meant to be primitives of deep structure in syntax, distinct from the interpretative semantic component, whereas Chafe's  $\overline{V}$  N configurations are meant to be semantic rather than syntactic, syntax being incorporated into semantics.

In equating deep structure with semantic structure, abstract syntax, a development within transformational generative grammar, is similar to Chafe's generative semantics. In fact, Lakoff (1971) likewise labels his theory 'generative semantics'. In abstract syntax, however, many of Chafe's selectional and inflectional units and even certain lexical units are considered as separate predicates of hierarchically embedded one-place or two-place functions or propositions, certain clusters of which are eventually realised as lexical items: for example, (cause (become (not (live)))) → 'kill'. In abstract syntax, moreover, lexemes (constituted by sound and meaning) are inserted in the course of the derivation (after certain prelexical transformations but prior to syntactic transformations). In Ross's view (see McCawley 1968b), lexical insertion can take place at any point in the derivation. On the other hand, Chafe's model considers lexical units as 'semantoids', without phonological correlates, selected as a result of previous selectional specifications and further specifiable by inflectional units. Eventually, lexical units are symbolised in surface structure, but only after the application of post-semantic processes.

In postulating a basically nonlinear semantic structure, Chafe's model has features in common with Halliday's (1966) concept of 'deep grammar'.

#### 0.4. SCOPE, LIMITATIONS, AND PURPOSES OF THE STUDY

In this study, an initial exploratory one at best, no more than an outline of the principal semantic structures of Pampangan and the rules for generating such semantic structures will be attempted.

Although this model of language lends itself to the exploration of idiom formation and analysis (see Chafe 1968, 1970a:129-30, 1970b:106-8), no attempt will be made to account for anything other than literal speech, except in connection with temporal dimensions which are often literalised as spatial dimensions. Moreover, although suggestions will be made on the necessity of ordering rules with regard to other rules, no claim will be made for either completeness or adequacy of the rule

statements and their ordering. The formulations are tentative and will undoubtedly demand revision as new data are accounted for. Still, the claim will be made that the rules formulated at least account for the examples cited and that the rules suggest the types of formulations which must be considered in accounting for semantic structures.

Considerations will be confined solely to the content side of language, the phonological processes of Pampangan being reserved, hopefully, for a latter study of Pampangan phonology based on the model of generative phonology, with full cognisance of the necessary 'grammatical pre-requisites'.

For the purposes of this study, the validity of Chafe's model as one among other possible models for accounting for structures on the content side of language will be assumed. The notation, rule format, manner of presentation, and where applicable, terminology for semantic units of Chafe 1970a, b will be used. By applying the model to a member of a language family (Austronesian) to which as yet it has not been applied, the study will test the applicability of the model and examine its descriptive power.

With the study of semantic structures still in its beginning stages, the structures described for Pampangan will be partial rather than complete descriptions. Still, it will be only through a study of the semantic structures (units and configurations) and of various post-semantic processes in diverse languages that insight will be gained into the nature of the structure of the content side of language.

On the expression side of language, linguists are well on the way towards arriving at a universal phonetic framework, a frame of reference with which they can study the phonological component of languages. The progress achieved in the quest for phonological universals and for phonological constraints (formulated in the theory of marking conventions and of language-universal redundancy rules) has been made possible through a survey of the phonological structures of the major languages of the world, a survey which has liberated linguistics from a too narrow conception of what is phonologically possible and what is phonologically 'natural'. It is hoped that a comparable direction will be taken in the study of the content side of language. And it is towards this general goal that this study ultimately proposes to make a contribution.

An examination of the selectional, lexical, and inflectional units as well as of the different possible  $\sqrt{N}$  configurations of a language of the Austronesian family will manifest both similarities with and differences from comparable units in English, in Onondaga, and in

Wichita (Rood 1970), languages to which the model has been applied. The study of similarities will point the way towards semantic universals. On the other hand, the discovery of dissimilarities will point the way towards the locus where languages actually differ, in the delicacy of distinctions made, in the sub-categories required, in the variety of pos-semantic processes.

More particularly, this study of the semantic structure of Pampangan aims to contribute to the progress of the study of the Philippine languages by exploring the content side of this language through an avenue of investigation not hitherto traversed with method in the past.

#### 0.5. PLAN OF THE STUDY

Chapter I, the key chapter, describes the semantic structures of Pampangan through specification and replacement rules developing V and its co-occurring N's. Chapter II describes the main post-semantic processes in Pampangan, again through specification and replacement rules which eventually lead to surface structures. Chapter III discusses semantic structures consisting of more than one V. Chapter IV proposes the notion of 'pre-semantic structure' to account for uses of language other than cognitive. Chapter V summarises the conclusions of the study and evaluates the descriptive power of the model through comparison of its empirical results with the conclusions of Berganö's pedagogical grammar, Lopez's survey of surface syntactic features, Castrillo's taxonomy of construction types, and Constantino's generative (phrase-structure and transformational) rules.

## N O T E S

1. The sources for this section, to be listed separately in the bibliography, were made available during several weeks of research at the Newberry Library in Chicago during the summer of 1968. I am grateful to the administration of the Newberry Library for enabling me to have access to these otherwise unavailable sources, so conveniently gathered in one locus.
2. In the Bergaño edition available to me, the third (1916) edition, based on the second (1736) edition, no mention is made anywhere of Benavente.
3. Of Bergaño's grammar, Pardo de Tavera (1903:54) notes: 'Es la primera gramática que se ha publicado'. On the other hand, Blake (1920:38) lists Coronel's grammar as a published work. In view of the fact that in 1875, Coronel's work was released as a 'reimpresión', it seems that on this point, Blake's datum is to be preferred to Pardo de Tavera's. Unfortunately, I have had no access to Coronel's grammar. Neither the Institute of National Language in Manila nor the Newberry Library in Chicago has a copy of Coronel's 1617 grammar or his 1875 'reimpresión'. Blake states that a manuscript by Coronel entitled 'Arte y Reglas de la Lengua Pampanga' is in the Eduardo Navaro [sic?] Collection in Valladolid, Spain.
4. I am grateful to my colleagues at De La Salle College, Manila, Professor Marcelino Foronda, Jr and Stephen La Brie, F.S.C. for facilitating access to the Bergaño volumes and the Castrillo thesis as well as for providing me with relevant data from the Bureau of Census and Statistics and from the Institute of National Language.

## CHAPTER I

### SEMANTIC PROCESSES

#### 1. INTRODUCTION

The first part of this chapter describes and exemplifies specification rules for developing V (whether it be a state, a process, an action, or a process-action), replacement rules for stating the co-occurring role-marked N's that accompany different types of V, verb derivational processes, and specification rules for verb inflectional units. The second part of the chapter describes specification rules for N selection, noun derivational processes, and specification rules for noun inflectional units. The third part discusses new and old information, and the fourth part describes the notion of topic. A summary of these processes is given in the final part by showing the step-by-step derivation of a Pampangan sentence.

All citations will be given in a broad phonetic transcription, with accent marked as primary in every instance. Where useful for explanatory purposes, the underlying phonological representation of an utterance will be transcribed, marked by an asterisk (\*). Citations unacceptable to a native speaker will be marked <sup>x</sup>AAA, while those of dubious acceptability will be marked <sup>?</sup>AAA.

For purposes of phonetic representation, the following inventory will be used: p b t d k g ? s m n ŋ w y l r ; i e a o u.

Clardy (1959) would add č, ĵ, and h to the list. Other than in loanwords from Spanish (which Clardy cites with native words), č and ĵ arise optionally and predictably only in t+i and d+i sequences. The formatives cited by Clardy for h are Tagalog loanwords. The usual reflex of UA \*h is Ø in Pampangan, at least in the dialects of the informants for this study. In other words, the Pampangan dialects used for the data are h-less dialects.

The glottal stop ? functions distinctively only in final position; in initial position, it is optional. Unlike Tagalog, Pampangan inserts no glottal stop between vowels (Tagalog ta?o, Pampangan tau 'man'), although like Tagalog, Pampangan sometimes inserts other glides between two successive vowels, the most common being y. Hence, although Dempwolff's hypothesised canonical form \*CV(C)CVC is useful in considering reconstructed forms, VV, VCV, VCVC formatives are quite common in Pampangan. In this study, glottal stop will be indicated only when it occurs in final position.

Other than for its accentual rules and boundary deletion rules, the phonology of Pampangan is relatively simple, as the differences in phonological shape between the underlying forms and the phonetic representations are minimal. Some of these phonological rules are: (a) the loss of glottal stop in final position when not followed by pause (aduá? 'two' but aduá la 'they are two [in number]', aduá + ŋ balé 'two houses'); (b) monophthongisation (\*matáy > maté 'die', \*babáw > bábo 'above'); (c) optional affrication of stops before a front vowel (\*atf+yu > ačú 'he is here'; Spanish medio > midiú > mijú 'almost'); (d) glide insertion (\*ka+ábay > kayábe 'companion'); (e) rhotacisation: \*d > r in intervocalic position. (The exceptions to this last rule are best explained by considering historical and comparative data; where this rule does not apply, it usually means that a different protophone must be posited; for example, aduá? 'two', not <sup>x</sup>aruá?, but \*ma+dayú? márayú? 'far'.)

The sound shifts that Spanish loanwords undergo in Pampangan demand separate study; especially intriguing are the accentual shifts; for example, Spanish Ana, Pampangan Ána, but Spanish María, Pampangan Maryá and Spanish para 'for', Pampangan pará.

It will be shown in Chapter II that the occurrence of the ligature -ŋ/a (malagu+ŋ dalága 'beautiful young woman', masantíŋ a anák 'pretty child') is structurally significant and is indicative of an incorporation process; it would seem then that the occurrence of the ligature should be postulated by a direct symbolisation process rather than by a post-symbolisation phonological process. (This will be explained in detail in Chapter II).

The 'suprasegmentals' or what Clardy (1959) calls 'second-order phonemes' present many problems. Lopez (1965), Constantino (1965), and Castrillo (1955) posit a phoneme of stress /' / distinct from a phoneme of length /·/. In actual citations, however, Constantino seldom uses the stress mark, since he states that stress is for the most part predictable. Only length is marked, therefore, unless the stress is unpredictable, in which case, of course, stress is indicated. On the

other hand, Clardy's study, the most detailed and comprehensive study thus far of Pampango phonology, posits two phonemes of pause (/|/ and /||/) and four pitch phonemes (/˘/ high-fall, /-/ high level, /˘/ level-rise, /-/ level-level). The first phoneme of pause is equivalent to vowel length and is alternatively written as /V·/. Using the contour ('a sequence of one or more integral numbers of syllables delimited by one pause phoneme accompanied by one pitch phoneme'<sup>123</sup>) as the unit of minimal utterance, stress is postulated as predictable on the basis of the pause phonemes and the pitch phonemes. Hence, although Clardy posits three degrees of phonetic stress ([˘], [˘], [ ]), stress is not considered a separate phoneme.

The study of 'suprasegmentals' demands re-examination in the light of advances in the theory of generative phonology as well as in the light of advances in techniques of instrumental investigation. Clardy's work suffers particularly from failure to note necessary grammatical pre-requisites, in other words, from failure to take full cognisance of the content side of language in studying the expression side. Her data, as a result, demand re-interpretation in this area of the suprasegmentals.

It is quite clear that the distinctive feature 'accented' must be posited as one of the features of the Pampangan sound system. Thus, there are minimal pairs which are semantically unrelated and which differ in their symbolisation only by the position of the accent (for example, báka| 'iron' and baká| 'provenience for a journey'.). In the lexical representation of such formatives, accent would have to be indicated. There is likewise morphological accent in Pampangan (see Wang 1968 for a discussion of lexical, morphological, and syntactic accent): mipaglákad 'will compete in walking', mipáglákad 'competed in walking'. The accentuation of such verb paradigms is straightforward and predictable. In the following morphologically related subset of forms, however, the accentuation is unpredictable: másakít 'sick', masákit 'difficult', masakít 'painful', from sakít 'sickness'.

The acoustic correlates of the distinctive feature 'accented' must be investigated separately. Through better instrumental techniques, it has been discovered that the acoustic correlates of accent (or stress) in nontonal languages consist of three features which normally co-occur: higher fundamental frequency, greater amplitude, longer duration (see, for example, my own study, 1970, of the acoustic correlates of accent in Tagalog, a closely related Philippine language). Hence, to separate perceived length from perceived loudness and perceived pitch rise seems to be unwarranted, since as a matter of fact, in most instances of accent, the accented vowel is usually higher in

pitch, louder, and longer. Length, however, varies according to the segmental composition of the syllable. Accented vowels in open syllables are usually longer than accented vowels in closed syllables; in Pampangan, accented vowels in closed syllables are not noticeably long: [lǎ:kad] 'to walk' but [talakád] 'stance'. Moreover, if the accented open syllable is in final position, its length is likewise not noticeable: [balé] 'house'.

That length is not always a concomitant of accent is shown by the previous examples and even more dramatically by the following formatives: [má:sakít] 'sick', [masá:kit] 'difficult', and [masakít] 'painful'.

Hence, while length usually accompanies accent, other factors may intervene to reduce or noticeably increase such length, such factors being the inherent length of the segments (for example, fricatives are inherently longer than stops) and the segmental composition of the syllable.

In my notation, therefore, such concomitant length resulting from accent and non-final open syllabicity is not marked.

In polysyllabic formatives, especially in V roots with affixes, the sequence of segments may have more than one accent: lǎkad 'to walk', lǎlǎkad 'walking'. In a more adequate description of the phonology, there will most likely be need for value-reduction rules of accent, from value 1 to value 2 in the secondary accent (the accent not on the root). Hence:

lǎlǎkad  
1 1  
2

It is not clear whether vowels with primary accent have to have greater values in their acoustic measurements than vowels with secondary accent. Perhaps the distinction is purely phonological rather than phonetic, since (extrapolating from the Tagalog data) the acoustic measurements of primary accent are not consistently greater than the acoustic measurements of secondary accent. There will probably be need for only two numerical values of phonetic accent, since Pampangan phrases do not rise to a peak (as they do, for example, in English). Thus, in a sentence such as

(1.0.1) púpútut yaŋ dútuŋ # i Pédru  
2 1 1 1  
'Pedro is cutting wood.'

only two values are necessary, since the initial verb phrase (with object) does not rise to a peak. In Chapter II, however, it will be

shown that when the latter part of the sentence is old information, there is usually a drop in pitch between the first part of the sentence (the predicate) and the second part of the sentence (the subject):

\_\_\_\_\_ # \_\_\_\_\_

This phenomenon can probably be formally noted by positing another rule which would reduce the accent value in the phrase expressing old information to value 3:

púpútut	yaŋ	dútuŋ	#	i	Pédru
1 1		1			1
2 1		1			1
2 1		1			3

The preceding remarks are by way of proposal. In the citations given in this study, as was stated earlier, examples will be transcribed with all accents as primary. The accent reduction rules of Pampangan are not clear at present and demand further investigation.

In this study, too, # will mark phrase boundary. Space indicates word boundary. Traditional Pampangan orthography is divided on the means of representing pronouns and determiners (mostly atonic) as either incorporated into the verb or the noun root, or not. Such particles are clearly minimal free forms and are moved in certain permutations. Determiners may be separated from nouns by intervening modifiers. Hence, both pronouns and determiners will be considered separate words and will be transcribed as free forms, separated from the principal verbs and nouns by spaces. Morpheme boundaries within words, where there is need to explicitly mark them in underlying representation, will be indicated by +.

## 1.1. SPECIFYING V

### 1.1.1. State Verbs

Consider the following sentence:

(1.1.1.1) madalumdúm  
'It is dark.'

(\*ma+dalumdúm 'dark' (lit. *darkness* + plenitiver)). Such a state V is specified as ambient and requires no accompanying N. A location N and/or a time N may occur with an ambient state V, as in:

(1.1.1.2) madalumdúm # kiŋ balé # ketáŋ aldó  
'It was dark in the house on that day.'

(\*baláy 'house' with determiner kiη, \*aldáw 'day' (lit. sun) with demonstrative determiner kéta and ligature + η). Such optionally occurring location and time nouns (traditional adverbial phrases of place and time) will be treated in Chapter III as traceable to separate V's.

Non-ambient state V's require a patient N:

(1.1.1.3) másakít ya # iη táu  
*'The man is sick.'*

(\*ma + sakít 'sick' (lit. sickness + plenitiviser), ya 'he', táu 'man' with subject determiner iη).

A state V may be specified as localised, in which case it demands an accompanying location N, as in:

(1.1.1.3a) másakít ya # (kiη) buntúk # iη táu  
*'The man is sick in the head.' = 'The man has a headache.'*

(buntúk 'head' with optional determiner kiη), where buntúk is a location N and táu is a patient N.

The state V may be a derived form (a predicate noun):

(1.1.1.4) albuláryu ya # i Pédru  
*'Pedro is a herbist.'*

(albuláryu 'herbist', from Spanish herbolario, ya, 'he', i, subject determiner for proper nouns), where the state V is semantically analysable as herbist + predicativiser, a predicate noun.

Instead of ambient, a state V may be specified as abilitative, in which case the patient N must be selectionally specified as potent, that is, as a potential agent:

(1.1.1.5) mákalákad ya # i Pédru  
*'Pedro is able to walk.'*

(\*maka + lákad 'able to walk' (lit. walk + abilitativiser)).

Or a state V may be specified as mensurative, in which case it must be accompanied by a measure N (in addition to a patient N):

(1.1.1.6) makába yaη atlúη yárda # iη imálan  
*'The cloth is three yards long.'*

(\*ma + kába? 'long' (lit. length + plenitiviser), ya 'it', + η, ligature, atlú? 'three', yarda 'yard' from Spanish yarda, imálan 'cloth').

A state V may likewise be specified as motivative, in which case, instead of a patient N, a motive N is demanded:

(1.1.1.7) mákatúla ya # iη búbu  
*'The clown is motivative of laughter.'*

(\*maka + túla? 'funny' (lit. *joy, laughter* + *motivativiser*), búbu 'clown' from Spanish bobo 'stupid'); the label 'motivative' has purposely been chosen instead of 'causative' because of the use of the label 'causative' in some other combination. It is possible for a motivative state V to be accompanied by both a patient N and a motive N, as in:

- (1.1.1.8) mákamaté # kaṅ Pedru # iṅ sakít  
 'The sickness is motivative of death to Pedro.' =  
 'The sickness is causing Pedro to die.'

(\*maka + matáy 'causing death' (lit. *death* + *motivativiser*), sakít 'sickness'), where Pédrú is a patient N and sakít is a motive N.

Again, a state V may be specified as experiential:

- (1.1.1.9) bísa yaṅ áutu # i Pédrú  
 'Pedro is in a state of wanting a car.' =  
 'Pedro wants a car.'

(\*bísa? 'want (a state, not a process)', ya 'he', áutu 'car' from Spanish auto), where áutu is a patient N and Pédrú is an experiencer N.

Or a state V may be specified as presential:

- (1.1.1.10) atí yu # i Pedro  
 'Pedro is present.' = 'Pedro is here.'

(atí 'present', yu 'he', an allosymbol for ya 'he'). The presential state V root is likewise used for existential sentences:

- (1.1.1.11) atín táu  
 'There is a man.'

(atín 'exists', the same root as atí, táu 'man'; the sentence has no subject). In the rules, only the label 'presential' will be used hereinafter. Presential state V's may be accompanied by a location N:

- (1.1.1.12) atí yu # kiṅ balé # i Pédrú  
 'Pedro is present in the house.'

A state V may be alternatively specified as directional, to or from, in which case it must be accompanied by a goal or a source N (in addition to a patient N):

- (1.1.1.13) papuntá ya # kiṅ balé # i Pédrú  
 'Pedro is in a state of going to the house.' =  
 'Pedro is headed for the house.'

- (1.1.1.14) íbát ya # kiṅ balé # i Pédrú  
 'Pedro is in a state of having come from the house.'

where both papuntá 'headed for' and íbát 'coming from' are derived

V's from inherent action V's, with the addition of the derivational unit de-activatiser.

State V may be further specified as habitive or necessitative, in which case state V must be accompanied by a beneficiary N in addition to a patient N:

(1.1.1.15) atín yaṅ áutu # i Pédru  
'Pedro has a car.'

(1.1.1.16)\* kailáṅan na ya naṅ Pédru # iṅ áutu >  
kailáṅan neṅ Pédru # iṅ áutu  
'The car is needed by Pedro.'

(atín 'have', kailáṅan 'in a state of needing', na 'non-subject he', ya 'subject it'), where áutu is a patient N in both sentences and where Pédru is a beneficiary N in both sentences.

Still another possible specification for state V is associative, in which case an associate N must accompany state V (in addition to a patient N):

(1.1.1.17)\* ka + ábay na ya naṅ Pédru # iṅ anák >  
kayábe neṅ Pédru # iṅ anák  
'The child is in the company of Pedro.'

(\*ka + ábay 'in the company of'), where Pédru is a patient N and anák is an associate N.

A state V may likewise be specified as similaritative, in which case a norm N is demanded (in addition to a patient N):

(1.1.1.18) antí yaṅ bábi # in táu  
'The man [looks] like a pig.'

(antí 'like', ya 'he', \*bábuy 'pig', táu 'man' with subject determiner iṅ), where táu is a patient N and bábi? is a norm N.

Pampangan has no verb roots comparable to English 'be, belong to, be intended for, takes place, be part of'. Instead of a lexical root, such state V's in Pampangan are eventually symbolised as  $\emptyset$ , although semantically, a V with certain selectional specifications has to be posited. Consider the following sentence:

(1.1.1.19) kaṅ Pédru ya # iṅ áutu  
'The car [belongs] to Pedro.'

where semantically, V is a state V specified as possessive; with such possessive state V's, a beneficiary N, the possessor, Pédru, is necessary in addition to a patient N, the object possessed, áutu. The beneficiary N is marked by the oblique determiner for proper nouns, kaṅ. It seems

that in instances of this sort, the matrix  $\left[ \begin{array}{c} V \\ \text{state} \\ \text{possessive} \end{array} \right]$  is not lexically specified and is eventually deleted. Because of this, the pronoun *ya* 'it' is incorporated into the beneficiary noun phrase instead of the usual verb phrase. (This incorporation process will be described more fully in Chapter II.)

One may likewise say:

- (1.1.1.20) *pará kaṅ Pédro ya # iṅ átu*  
*'The car [is intended] for Pedro.'*

where semantically V is a state V specified as intentive. A beneficiary N, *Pédro*, is demanded in addition to a patient N, *átu*. *pará* is a loanword from Spanish *para* 'for'. The position of *ya* in surface structure is usually after the verb root. In the above sentence, however, *ya* is postposed to the end of the beneficiary noun phrase, a clear indicator that the loanword *pará* is not considered in Pampangan a verb root but an element of the beneficiary noun phrase. If *pará* were a borrowed verb root, one would have to say:

$^x$ *pará ya # kaṅ Pédro # iṅ átu*

Moreover, one may likewise say:

- (1.1.1.21) *kaṅ Márkus ya # i Pédro ~*  
*pará kaṅ Markus ya # i Pédro*  
*'Pedro is in a favouritive stance towards Marcos as a political candidate.'* = *'Pedro is for Marcos.'*

where the state V is not specified as favouritive and demands a beneficiary N, *Márkus*, and a patient N, *Pédro*. Again, the matrix  $\left[ \begin{array}{c} V \\ \text{state} \\ \text{favouritive} \end{array} \right]$  is eventually deleted because not lexically specified.

*ya* 'he' is incorporated into the beneficiary noun phrase since there is no verb root to which it can be incorporated.

In the sentence

- (1.1.1.22) *kiṅ balé # iṅ taú?*  
*'The banquet [is taking place] in the house.'*

the state V is locative but without lexical specification (and post-semantically deleted), necessitating an accompanying location N, *balé*, in addition to a patient N, *taú?*. The non-occurrence of the pronoun *ya* 'it' in this sentence will be explained in section 1.2.1. For more specific expressions of location, combinations of location N and partitive N are used in Pampangan:

- (1.1.1.23) *kiṅ kilúb na niṅ balé # iṅ taú?*  
*'The banquet [is taking place] in the interior of the house.'* = *'The banquet is taking place inside the house.'*

(kilúb 'interior' from \*luʔub, na 'non-subject non-oblique it' co-referential with balé). The phrase kiŋ kilúb na niŋ balé 'in the interior of the house' does not seem to be traceable to an embedded sentence, since the following sentence does not occur in Pampangan:

<sup>x</sup>kiŋ balé ya # iŋ kilúb  
'The interior [is part of] the house.'

It would seem then that the phrase 'in the interior of the house' must be generated directly in semantic structure, that is, locative state V's must be accompanied by a location N and may be accompanied by a partitive N. The rules at the end of this section will formulate this latter generalisation.

Instead of locative, a state V may be specified as temporal:

(1.1.1.24) kéŋ lúnis # iŋ taúʔ  
'The banquet [will take place] on Monday.'

(lúnis 'Monday' from Spanish lunes), where the state V is now temporal and is accompanied by a time N in addition to a patient N. The determiner for the time N is a demonstrative determiner, kéŋ, lit. 'that near you'.

Or a state V may be specified as partitive, as in:

(1.1.1.25) kiŋ balé ya # iŋ pasbúl  
'The door [is part of] the house.'

where once more, the state V is specified as partitive but is not lexically specified and is eventually deleted; partitive state V's are accompanied by a partitive N in addition to a patient N.

A state V not marked by further selectional units may be specified inflectionally by the unit equative, in which instance it demands a norm N:

(1.1.1.26)\* kasíŋ ka+taʔás na ya niŋ túkud # iŋ anák >  
kasíŋ kátas ne niŋ túkud # iŋ anák  
'The child is as tall as the stick.'

(kasíŋ 'equativiser', kátas 'tall, high' from \*taʔás 'height' and \*ma- > ka-, túkud 'walking stick, cane'), where anák is a patient N and túkud is a norm N.

Instead of equative, a state V may be inflectionally specified as comparative; in such an instance, a norm N is likewise demanded:

(1.1.1.27) (mas) mátas ya # kiŋ túkud # iŋ anak  
'The child is taller than the stick.'

(mas 'more' from Spanish más, \*ma+ta?ás 'tall, high (lit. height + plentiviser)'), where túkud is a norm N and anák is a patient N. Pre-Spanish Pampangan had no symbolisation for 'more'; the Spanish loanword is still optional.

Finally, a state V may be inflectionally specified as superlative, in which case it demands a partitive N which is inflectionally specified as plural and total:

(1.1.1.28) pékamátas yaŋ díli # karíŋ gaŋ ának # i Pédrú

*'Pedro is the tallest of all among all of the children.'*

(\*péka+ma+ta?ás 'tallest' (lit. height + plentiviser + superlativiser), díli 'of all', ának 'children' with the oblique plural determiner \*ka+diŋ and gaŋ 'all'), where ának is a partitive N inflectionally plural and total and where Pédrú is a patient N. (Note the accent shift in: anák 'child' > ának 'children'.)

It seems that the inflectional specifications 'equative', 'comparative', and 'superlative' occur only with state V's not further specified by other selectional units, except for the unit 'mensurative', which may occur with comparative:

(1.1.1.29) (mas) mátas yaŋ aduáŋ talíri # kiŋ túkud # iŋ anák

*'The child is taller than the stick by two fingers.'*

(aduá? 'two', talíri? 'finger'), where the state V is accompanied by a patient N, anák, a norm N, túkud, and a measure N, talíri? (with the numeral specification). (Note that adua? is an exception to the \*d > r rule earlier mentioned and that -r- in talíri? is not from underlying \*d, since there is no formative <sup>x</sup>talídi?.)

In summary, V may be specified as state. A state V may be specified as ambient, localised, abilitative, mensurative, motivative, experiential, presential, directional (to or from), habitive, necessitative, associative, similaritative, possessive, intentive, favouritive, locational, temporal, or partitive.

An ambient state V does not demand an accompanying N; a localised state V demands an accompanying location N; a mensurative state V demands a measure N; a motivative state V demands a motive N; an experiential state V demands an experiencer N; a presential state V may be accompanied by a location N; a directional-to state V demands a goal N; a directional-from state V demands a source N; a necessitative state V and a habitive state V demand a beneficiary N; an associative state V demands an associate N; a similaritative state V demands a norm N.

The following sub-types of state V's are not lexically specified: possessive, intentive, favouritive, locational, temporal, partitive. Possessive, intentive, and favouritive state V's demand a beneficiary N; temporal state V's demand a time N; partitive state V's demand a partitive N; locative state V's demand a location N which may be accompanied by a partitive N.

In addition, all the above sub-types of state V (except for ambient and motivative state V's) demand an accompanying patient N; a motivative state V may be accompanied by a patient N but does not demand one. If the state V is abilitative, the accompanying patient N must be selectionally specified as potent.

Inflectionally, a state V which is not further specified by other selectional units may be specified as equatative, comparative, or superlative. A mensurative state V may likewise be inflectionally specified as comparative. A state V inflectionally specified as either equatative or comparative demands an accompanying norm N in addition to a patient N. A state V inflectionally specified as superlative demands a partitive N inflectionally specified as plural and total.

The preceding generalisations may be re-stated in the form of semantic generative rules. The rules set down below are numbered thus: S1.1.1.1' means 'Semantic Rule number 1 in Chapter I, Part 1, Section 1'. The apostrophe indicates that the formulation is tentative and that the rule will be re-formulated in the section on Re-statement of Rules. The braces - { } - are an abbreviation for exclusive disjunction, either/or, while the parentheses - ( ) - are an abbreviation for inclusive disjunction, and/or.

(S1.1.1.1')	V	->>	state																		
(S1.1.1.2')			<table border="0"> <tr><td>ambient</td></tr> <tr><td>localised</td></tr> <tr><td>abilitative</td></tr> <tr><td>mensurative</td></tr> <tr><td>motivative</td></tr> <tr><td>experiential</td></tr> <tr><td>presential</td></tr> <tr><td>directional</td></tr> <tr><td>habitive</td></tr> <tr><td>necessitative</td></tr> <tr><td>associative</td></tr> <tr><td>similaritative</td></tr> <tr><td>possessive</td></tr> <tr><td>intentive</td></tr> <tr><td>favouritive</td></tr> <tr><td>locative</td></tr> <tr><td>temporal</td></tr> <tr><td>partitive</td></tr> </table>	ambient	localised	abilitative	mensurative	motivative	experiential	presential	directional	habitive	necessitative	associative	similaritative	possessive	intentive	favouritive	locative	temporal	partitive
ambient																					
localised																					
abilitative																					
mensurative																					
motivative																					
experiential																					
presential																					
directional																					
habitive																					
necessitative																					
associative																					
similaritative																					
possessive																					
intentive																					
favouritive																					
locative																					
temporal																					
partitive																					
	state	->>																			



(S1.1.1.14')	V similaritative	→	V similaritative	norm N
(S1.1.1.15')	V locative	→	V locative	location N partitive N
(where the broken line indicates optional accompaniment)				
(S1.1.1.16')	V temporal	→	V temporal	time N
(S1.1.1.17')	V partitive	→	V partitive	partitive N
(S1.1.1.18')	V {equatative } {comparative}	→	V {equatative } {comparative}	norm N
(S1.1.1.19')	V superlative	→	V superlative	partitive N plural total
(S1.1.1.20')	V state -ambient (abilitative)	→	V state -ambient <(abilitative)>	patient N <potent>

where the angle brackets < > stipulate obligatory co-occurrence, N must be potent if V is abilitative.

This rule is optional for V  
state  
motivative

#### Sample Lexical Rules

V selectional units narrow down the selection of the verb root to a particular unit, which may be basic or derived (see section 1.1.7 for verb derivational processes). Lexical Rules are thus formulated as specification rules with a matrix of selectional units as context. Samples of such rules are formulated in this section. As a notational convenience, root classes, as distinguished from particular roots, will be written in capital letters.

- (LR1.1.1.1) V  
state → *sickness* + plenitiviser,  
*herbist* + predicativiser,  
*beauty* + plenitiviser,...
- (LR1.1.1.2) V  
state → *darkness* + plenitiviser,  
ambient *light* + plenitiviser,...
- (LR1.1.1.3) V  
state → (PROCESS-) ACTION VERB ROOT +  
abilitative abilitativiser
- (LR1.1.1.4) V  
state → *length* + plenitiviser,  
mensurative *width* + plenitiviser,...
- (LR1.1.1.5) V  
state → VERB ROOT/NOUN ROOT +  
motivative motivativiser
- (LR1.1.1.6) V  
state → *be in a state of wanting*,  
experiential *be in a state of liking*...
- (LR1.1.1.7) V  
state → *be present, exist*...  
presential
- (LR1.1.1.8) V  
state → *headed for, pointed to*,  
directional DIRECTIONAL ACTION  
to VERB ROOT + de-activativiser,...
- (LR1.1.1.9) V  
state → *coming from, originating from*,  
directional DIRECTIONAL ACTION VERB ROOT +  
from de-activativiser,...
- (LR1.1.1.10) V  
state → *have*  
habitive
- (LR1.1.1.11) V  
state → *be in a state of needing*,  
necessitative *be in a state of lacking*,...
- (LR1.1.1.12) V  
state → NOUN ROOT/VERB ROOT +  
associative associativiser
- (LR1.1.1.13) V  
state → *be like to*  
similaritative
- (LR1.1.1.14) V  
state → ∅ (no lexical root specification)  
{  
intensive  
possessive  
favouritive  
locative  
temporal  
partitive  
}

## 1.1.2. Process Verbs

Consider the sentence:

- (1.1.2.1) múmurán  
'It is raining.'

(\*m+urán 'to rain' (lit. *rain* + processiviser)), where the verb root is inflectionally specified for actual durative aspect by re-duplication of the initial syllable. Non-state V's may be inflected for other aspects: murán 'it will rain', minurán 'it rained', kauránurán 'it has just rained'. (Most citations in this section and in the next two sections will be given with actual durative inflection.) Process V's answer the question 'What's happening?'. Meteorological nouns such as 'rain, thunder, lightning' may be derived into process verbs by the addition of the derivational unit processiviser. Such process V's are specified as ambient. Like ambient state V's, ambient process V's require no accompanying N.

Non-ambient process V's demand a patient N:

- (1.1.2.2) mamamaté ya # i Pédrú  
'Pedro is dying.'

(\*matáy 'to die'; the triplication of the initial syllable is irregular). A process V may be specified as localised, in which instance it must be accompanied likewise by a location N:

- (1.1.2.3) mánasakít ya # kíŋ buntúk # i Pédrú  
'Pedro is hurting in the head.'

(\*mana+sakít 'to suffer pain' (lit. *sickness* + processiviser), buntúk 'head'), where buntúk is a location N and Pédrú is a patient N.

Alternatively, a process V may be specified as mensurative, in which instance it demands a measure N:

- (1.1.2.4) dŋnagúl yaŋ aduáŋ pulgáda # iŋ anák  
'The child grew by two inches.'

(dágul 'to grow' (lit. *size* + processiviser), pulgáda 'inch' from Spanish *pulgada*), where pulgáda is a measure N and anák is a patient N.

Or a process V may be specified as benefactive:

- (1.1.2.5) kamamatén yaŋ manúk # i Pédrú  
'Pedro is being bereft of chickens (for example, because of some pestilence).'

(\*ka+matáy+an 'to be bereft' (lit. *die*, with beneficiary subject marker), manúk 'chicken(s)'), where manúk is a patient N and Pédrú is a (negative) beneficiary N.

Or a process V may be specified as habitive, in which case a beneficiary N is likewise required:

- (1.1.2.6) mágkasakít ya # i Pédrú  
*'Pedro is getting to have a sickness.'*

(\*magka+sakít 'to get sick' (lit. *sickness* + habitiviser)). In habitive process V's, no patient N occurs, since the semantic patient is incorporated through a derivational process into the verb root.

A process V may on the other hand be specified as necessitative, in which instance a beneficiary N is likewise demanded, in addition to a patient N:

- (1.1.2.7) mángailáñan yañ péra # i Pédrú  
*'Pedro is in the process of needing money.'*

(\*mañ+kailáñan 'to need' (lit. *need* + processiviser), péra 'money' from Spanish perra chica lit. *little dog*, colloquial for a five centime copper coin, so called because of the dog-like engraving on the coin), where péra is a patient N and Pédrú is a beneficiary N.

Or a process V may be specified as experiential, in which case an experiencer N is necessary:

- (1.1.2.8)\* ák+ákit na ya nañ Pédrú # iñ baláy >  
 ákákit neñ Pédrú # iñ balé  
*'The house is being seen by Pedro.'*

(ákit 'to see', na 'non-subject he', ya 'subject it'), where Pédrú is an experiencer N and balé is a patient N.

In summary, a V which is non-state may be specified as process. In turn, a process V may be further specified as ambient, localised, mensurative, benefactive, habitive, necessitative, or experimental.

Ambient process V's require no accompanying N. Localised process V's require a location N; mensurative process V's require a beneficiary N; experiential V's require an experiencer N. In addition, all process V's unless ambient or habitive, require a patient N.

These generalisations may be formulated by the following rules:

(Sl.1.2.1') V                                    ->> process  
 -state

(Sl.1.2.2')  
 process                                    ->>  $\left. \begin{array}{l} \text{ambient} \\ \text{localised} \\ \text{mensurative} \\ \text{benefactive} \\ \text{habitive} \\ \text{necessitative} \\ \text{experiential} \end{array} \right\}$

(Sl.1.1.2.3')	V localised	→	<table border="0"> <tr> <td></td> <td>┌──────────────────┐</td> <td>location</td> </tr> <tr> <td>V</td> <td></td> <td>N</td> </tr> <tr> <td>localised</td> <td></td> <td></td> </tr> </table>		┌──────────────────┐	location	V		N	localised		
	┌──────────────────┐	location										
V		N										
localised												
(Sl.1.1.2.4')	V mensurative	→	<table border="0"> <tr> <td></td> <td>┌──────────────────┐</td> <td>measure</td> </tr> <tr> <td>V</td> <td></td> <td>N</td> </tr> <tr> <td>mensurative</td> <td></td> <td></td> </tr> </table>		┌──────────────────┐	measure	V		N	mensurative		
	┌──────────────────┐	measure										
V		N										
mensurative												
(Sl.1.1.2.5')	V {benefactive habitive necessitative}	→	<table border="0"> <tr> <td></td> <td>┌──────────────────┐</td> <td>beneficiary</td> </tr> <tr> <td>V</td> <td></td> <td>N</td> </tr> <tr> <td>{benefactive habitive necessitative}</td> <td>{benefactive habitive necessitative}</td> <td></td> </tr> </table>		┌──────────────────┐	beneficiary	V		N	{benefactive habitive necessitative}	{benefactive habitive necessitative}	
	┌──────────────────┐	beneficiary										
V		N										
{benefactive habitive necessitative}	{benefactive habitive necessitative}											
(Sl.1.1.2.6')	V experiential	→	<table border="0"> <tr> <td></td> <td>┌──────────────────┐</td> <td>experiencer</td> </tr> <tr> <td>V</td> <td></td> <td>N</td> </tr> <tr> <td>experiential</td> <td></td> <td></td> </tr> </table>		┌──────────────────┐	experiencer	V		N	experiential		
	┌──────────────────┐	experiencer										
V		N										
experiential												
(Sl.1.1.2.7')	V process -ambient -habitive	→	<table border="0"> <tr> <td></td> <td>┌──────────────────┐</td> <td>patient</td> </tr> <tr> <td>V</td> <td></td> <td>N</td> </tr> <tr> <td>process -ambient -habitive</td> <td>process -ambient -habitive</td> <td></td> </tr> </table>		┌──────────────────┐	patient	V		N	process -ambient -habitive	process -ambient -habitive	
	┌──────────────────┐	patient										
V		N										
process -ambient -habitive	process -ambient -habitive											

## Sample Lexical Rules

(LR1.1.2.1)	V process	→→	<i>grow, die</i> , STATE VERB ROOT + processiviser,...
(LR1.1.2.2)	V process ambient	→→	<i>rain</i> + processiviser, <i>darkness</i> + processiviser,...
(LR1.1.2.3)	V process localised	→→	<i>hurt (in some part of the body)</i> ,...
(LR1.1.2.4)	V process mensurative	→→	<i>length</i> + processiviser, <i>width</i> + processiviser,...
(LR1.1.2.5)	V process benefactive	→→	<i>be bereft of (something)</i> ,...
(LR1.1.2.6)	V process habitive	→→	NOUN ROOT + habitiviser
(LR1.1.2.7)	V process necessitative	→→	<i>be in the process of needing</i> , <i>be in the process of lacking</i> ,...
(LR1.1.2.8)	V process experiential	→→	<i>see, hear, feel</i> ,...

## 1.1.3. Action Verbs

Consider the sentence:

- (1.1.3.1) lálákad ya # i Pédrú  
'Pedro is walking.'

An action V may be specified as causative, in which case it demands an agentive beneficiary N:

- (1.1.3.2)\* pá+lákad+an na ya niṅ doktór # i Pédrú >  
pálakáran ne niṅ doktór # i Pédrú  
'Pedro is being caused to walk by the doctor.'

(pálakáran 'to cause someone to walk' (lit. walk + causativiser), doktór 'doctor' from Spanish doctor), where doktór is an agent N and where Pédrú is an agentive beneficiary N, the recipient of the causative action who is an agent in his own right. The agentive beneficiary N is to be distinguished as a separate N relation from beneficiary N.

- (1.1.3.3) mipáglákad la # di Pédrú  
'Pedro and [his] companions are walking reciprocatively.' =  
'Pedro and [his] companions are competing in walking.'

(\*mipag+lákad 'to compete in walking' (lit. walk + reciprocativiser)), where the notion of competition is derived from the literal meaning of reciprocation. la means 'subject they' and is co-referential with di Pédrú 'Pedro and [his] companions'.

Instead of reciprocative, an action V may be specified as associative, in which instance an associate N is demanded:

- (1.1.3.4) mákilákad ya # kaṅ Suán # i Pédrú  
'Pedro is joining Juan in walking.'

(\*maki+lakad 'to join someone in walking' (lit. walk + associativiser)), where Pédrú is an agent N and Suán is an associative N.

Or, instead of reciprocative or associative, an action V may be specified as participative, in which case, a plural associative N must accompany V:

- (1.1.3.5) mákipaglákad ya # kari Suán # i Pédrú  
'Pedro is joining Juan and [his] companions in walking.'

(\*makipag+lákad 'to join a group in walking' (lit. walk + participativiser)), where the notion of participation (although clearly related to association) must be distinguished from the latter, since the former has to do with a group activity in which an agent shares.

An action V may be specified further as either completable or instrumental, in which case it demands either a complement N or an instrument N. A complement N is distinguished from a patient N insofar as a complement N 'completes' the meaning of the action V, is implied in the semantic content of the action V itself, as in *'to sing (a song), to make (an artifact), to read (a book), to give (a gift), to throw (an object)'*.

(1.1.3.6) gágawá yaŋ lamésa # i Pédru  
'Pedro is making a table.'

(1.1.3.7) gágámit yaŋ tabák # i Pédru  
'Pedro is using a large knife.'

(gáwa? 'to make', lamésa 'table' from Spanish la mesa 'the table', gámit 'to use', tabák 'a large knife'), where lamésa is a complement N and where tabák is an instrument N.

Instrumental action V's demand an instrument N which is implied in the action itself, for example, the inherent action V gámit 'to use' implies a tool of some kind. Again, a V such as manéu 'to drive' from Spanish manejo 'I drive' implies a vehicle. On the other hand, there are many action V's which do not imply the use of an instrument but may be performed with an instrument. For example, the action of walking implies no instrument but may involve an instrument, as in *'to walk with a cane'*. For such V's, the optional specification instrumentative will be used, as in:

(1.1.3.8)\* ipáŋ+lákad na ya naŋ Pédru # iŋ túkud >  
páŋlákad neŋ Pédru # iŋ túkud  
'The walking stick is being used by Pedro to walk with.'

(\*ipáŋ+lákad 'to walk' (with instrument subject marker), na 'non-subject he', túkud 'walking stick'), where Pédru is an agent N with non-subject determiner naŋ and where túkud is an instrument N with subject determiner iŋ. Instrumentative action V's are unusual insofar as they demand that the accompanying instrument N be subject. (Rules for such subjectivisation will be formulated in Chapter II.)

A completable action V may be further specified as materiative, in which case it demands an accompanying material N:

(1.1.3.9) gágawá yaŋ lamésa # kiŋ dútuŋ # i Pédru  
'Pedro is making a table out of the wood.'

(dútuŋ 'wood'), where dútuŋ is the material out of which something is made. Material N's occur only with verbs of making.

An action V may be specified as mensurative, in which case it demands a measure N:

- (1.1.3.10) lálákad yaŋ aduáŋ kilómetru # i Pédrú  
'Pedro is walking two kilometres.'

where kilómetru is a measure N. The specification mensurative may occur with the specification instrumental:

- (1.1.3.11)\* m+intanéú na yaŋ aduá?ŋ kilómetru naŋ Pédrú # iŋ áutu >  
minanéú neŋ aduáŋ kilómetruŋ Pédrú # iŋ áutu  
'The car was driven by Pedro for two kilometres.'

(minanéú 'driven' from \*manéú+an 'to drive (a vehicle)', with instrument subject marker), where kilómetru is a measure N and áutu is an instrument N. It seems, however, that the unit 'mensurative' does not occur with the unit 'completable', for in the following sentence:

- (1.1.3.12) miniyé yaŋ digálu # kiŋ alagáŋ aduáŋ pésus # i Pédrú  
'Pedro gave a gift to the value of two pesos.'

(miniyé 'gave' from \*biyáy, digálu 'gift' from Spanish regalo, alagá 'value', aduá? 'two', pésus 'peso' from Spanish pesos), it seems that the phrase 'to the value of two pesos' is actually a relative clause specifying digálu further, 'a gift which is worth two pesos'.

An action V may likewise be specified as benefactive, in which instance it demands a beneficiary N. It seems that for V to be specified as benefactive, it must be priorly specified as either completable or associative. The following examples will make this observation clear:

- (1.1.3.13) bíbiyé yaŋ péra # kaŋ Suán # i Pédrú ~  
babiyé yaŋ péra # kaŋ Suán # i Pédrú  
'Pedro is giving money to Juan.'

- (1.1.3.14)\* páki+lákad na ya naŋ Pédrú # kaŋ Suán # iŋ anák >  
páki+lákad neŋ Pédrú # kaŋ Suán # iŋ anák  
'The child is being associated with Juan by Pedro  
in walking.'

(\*biyáy 'to give' from UA \*bəɣaj 'Geben', paki+lákad 'to join someone in walking' (lit. walk + associativiser) from \*maki+lákad), where Pédrú is an agent N in both sentences, Suán is a beneficiary N in the first sentence and an associate N in the second sentence, and anák is a beneficiary N. There is a sentence in Pampangan:

- (1.1.3.15)\* pág+lákad na ya naŋ Pédrú # iŋ anák >  
 páglákad neŋ Pédrú # iŋ anák  
 'The child is being walked for by Pedro.' =  
 'Pedro is walking for the benefit of the child  
 (e.g. by running errands for him).'

where obviously anák is a beneficiary N. Such sentences, however, will be treated in Chapter III as surface structures of  $\overline{V}$  V configurations; justification will be given for the analysis adopted in the relevant sections in that chapter.

It is possible for the beneficiary N to be co-referential with the agent N (an example of the traditional dative of interest):

- (1.1.3.16) pálákad ya # i Pédrú  
 'Pedro is causing [someone] to take him for a walk.  
 (e.g., if he is incapacitated and has to be moved  
 about in a wheelchair).'

The above sentence likewise means 'Pedro is managing [things]', but this meaning will not be considered at this point. For a sentence such as 1.1.3.16, the semantic unit 'interestive' will be postulated as a possible further specification of benefactive. The necessary context is co-referentiality between the beneficiary N and the agent N. An alternative way of expressing more or less the same situation as 1.1.3.16 is:

- (1.1.3.17)\* pá+lákad na ya naŋ Pédrú # iŋ sadfli na >  
 pálákad neŋ Pédrú # iŋ sarfli na  
 'His self is being caused by Pedro to be walked.' =  
 'Pedro is causing himself to be walked.'

(\*pa+lákad 'to cause oneself to be walked' (lit. walk + causativiser), sarfli 'self', na 'his = non-subject he'), where the beneficiary N is specified by 'self' instead of the root Pédrú. Reflexive pronouns will be discussed in the relevant section on pronouns in Chapter II.

An action V may likewise be specified as directional, to or from, in which instance it demands either a goal N or a source N:

- (1.1.3.18) púpuntá ya # kiŋ balé # i Pédrú  
 'Pedro is going to the house.'  
 (1.1.3.19) mánibát ya # kiŋ balé # i Pédrú  
 'Pedro is coming from the house.'

(puntá 'to go to', manibát 'to come from'), where balé is a goal N in the first sentence and a source N in the second sentence.

The possible specifications of action V's are relatively straightforward and uncomplicated. Problems arise, however, when these specifications are examined for their combinatorial possibilities, for unlike the additional selectional specifications of state and process V's, many of the specifications of action V's are not mutually exclusive. These various combinatorial possibilities merit detailed investigation. The rules to be formulated are meant to be suggestive; they are tentative, since a definitive rule formulation would entail a survey of the complete V lexicon.

To take only three examples of a maximally specified action V:

(a) An action V may be specified as causative, reciprocative, completable, and benefactive:

(1.1.3.20)? mipágpabiyé laᅇ diᅇálu # kariᅇ ának # di Pédrú  
 # kariᅇ bábyi  
*'Pedro and [his] companions are competing [with each other] in causing gifts to be given by the women to the children.'*

where diᅇálu 'gift' is a complement N, ának is a beneficiary N, di Pédrú is a plural agent N, and bábyi is an agentive beneficiary N. In general, however, such a sentence would be avoided because of the ambiguity resulting from the common plural oblique marking of ának and bábyi, kariᅇ.

(b) An action V may be specified as causative, participative, completable, and if the root is gáwa? 'to make', accompanied likewise by a material N:

(1.1.3.21)? mákípagpagawá yaᅇ lamésa # kiᅇ dútuᅇ # i Pédrú #  
 kariᅇ bábyi # kaᅇ Suán  
*'Pedro is participating with the women in causing Juan to make a table out of the wood.'*

where lamésa is a complement N, dútuᅇ is a material N, Pédrú is an agent N, bábyi is a plural associate N, and Suán is an agentive beneficiary N. Again, however, because of the ambiguity of the oblique-marked N's (preceded by kiᅇ/kaᅇ or kariᅇ/kari), such a sentence would be avoided.

(c) An action V may be specified as causative, associative, directional to, and mensurative:

(1.1.3.22)? mákípalákad yaᅇ aduaᅇ kilómetru # kiᅇ anák #  
 kiᅇ Méníla? i Pédrú kaᅇ Suán  
*'Pedro is joining Juan in causing the child to walk two kilometres to Manila.'*

where kilómetru is a measure N, anák is an agentive beneficiary N, Ménlla? is a goal N, Pédru is an agent N, and Suán is an associate N. Again, however, because of the three oblique-marked N's (preceded by kaŋ/kiŋ), such a structure would be avoided.

What the three examples have demonstrated (many more can be cited) is that while there are no semantic reasons against maximally specifying an action V and postulating corresponding accompanying N's with it, there are post-semantic constraints on such specifications, since, as will be shown in Chapter II, all such N relations are ultimately marked by only three determiners, the subject determiner i/iŋ, the oblique determiner kaŋ/kiŋ, and the unmarked determiner naŋ/niŋ or if N is -definite  $\emptyset$ . These post-semantic constraints seem to be comparable to the global surface structure constraints of the abstract syntacticists.

The optimal number of co-occurring N's is therefore three; any more would result in homonymy with regard to the determiners. It is possible to go beyond the optimal number by having two kaŋ/kiŋ marked N's in surface structure or by having two naŋ/niŋ marked N's in surface structure with certain verb roots; in the latter case, one of the unmarked determiners is  $\emptyset$ . Beyond these limits, however, confusion results.

(1.1.3.23) pápabiyé yaŋ digálu # kiŋ anák # kaŋ Suán # i Pédru  
'Pedro is causing Juan to give gifts to the child.'

(1.1.3.24)\* pá+pa+dínan na ya+ŋ digálu naŋ Pédru # iŋ anák # kaŋ Suán >  
páparínan neŋ digálu Pédru # iŋ anak # kaŋ Suán  
'The child is being caused by Pedro to be given gifts  
by Juan.'

where digálu is a complement N, anák is a beneficiary N, Suán is an agentive beneficiary N, and Pédru is an agent N. For the purposes of this study, sentence 1.1.3.23 will be taken as a maximally specified V which is well within the limits of ease in semantic interpretation and will be used as a basis for discussion in Chapter II, where post-semantic processes will be discussed.

Another 'strategy' for avoiding homonymy with regard to the determiners, an alternative to limitation of occurring N's to optional three (or maximal four), would be to delete N's, provided the context permits such deletions (for example, if N is -new; see section 1.3 for a discussion of new and old information). Thus, it is possible to say, without any difficulty:

(1.1.3.20') mipágpabiyé laŋ digálu # kariŋ ának # di Pédru  
'Pedro and [his] companions are competing [among  
themselves] in causing gifts to be given [by somebody]  
to the children.'

(1.1.3.21') mákipagpagawá yaŋ lamésa # kiŋ dútuŋ # i Pédro  
*'Pedro is participating [with some people] in causing  
 a table to be made out of the wood [by somebody].'*

(1.1.3.22') mákipalákad yaŋ aduáŋ kilómetru # kiŋ anák # i Pédro  
*'Pedro is associating himself [with someone] in causing  
 the child to walk two kilometres [to some place].'*

In summary, a V which is neither a state nor a process V may be specified as an action V. An action V may be further specified as causative, and/or reciprocative/associative/participative and/or completable/instrumental and/or mensurative (if completable). A completable V may likewise be specified as materiative. A completable (but -materiative) or associate V may be further specified as benefactive; a benefactive V may be further specified as interestive if its accompanying agent N is co-referential with its beneficiary N. Moreover, an action V may be specified as directional (to or from). Finally, any action V may be specified as instrumentative if the action may be performed with some instrument.

A causative action V demands an agentive beneficiary N; a reciprocative action V demands a plural agent N; an associative action V demands an associate N; a participative action V demands a plural associate N. A completable action V demands a complement N, and an instrumental and an instrumentative action V demand an instrument N. A materiative action V demands a material N. A mensurative action V demands a measure N. A benefactive action V demands a beneficiary N. A directional-to action V demands a goal N, and a directional-from action V demands a source N. All action V's demand an agent N.

The following rules re-state the above generalisations. Lexical Rules will be formulated subsequently, exemplifying some of the different possibilities. The rules generate maximally specified V's, even configurations beyond the optimal limits earlier described.

(Sl.1.3.1') V                    - →            action  
           -state  
           -process

(Sl.1.3.2')

action

- →

causative

{ reciprocative  
 associative  
 participative }

{ completable  
 instrumental }

mensurative / V

-completable

(S1.1.3.3')	V action completable	- →	materiative
(S1.1.3.4')	V action {completable} associative}	- →	benefactive
(S1.1.3.5')	V -associative benefactive	→	interestive / N <sub>1</sub> N <sub>1</sub>
(S1.1.3.6')	V action -benefactive -materiative	→	directional
(S1.1.3.7')	directional	→	{ to } { from }
(S1.1.3.8')	V action	- →	instrumentative
(S1.1.3.9')	V causative	→	agentive beneficiary N
(S1.1.3.10')	V associative participative	→	associate N { associative <participative> }      <plural>
(S1.1.3.11')	V completable	→	complement N V completable
(S1.1.3.12')	V instrumental	→	instrument N V instrumental
(S1.1.3.13')	V mensurative	→	measure N V mensurative
(S1.1.3.14')	V materiative	→	material N V materiative

(Sl.1.3.15')	V benefactive	→	V benefactive	beneficiary N
(Sl.1.3.16')	V directional to	→	V directional to	goal N
(Sl.1.3.17')	V directional from	→	V directional from	source N
(Sl.1.3.18')	V action (reciprocative)	→	V action <(reciprocative)>	agent N <plural>
(Sl.1.3.19')	V instrumentative	→	V instrumentative	instrument N

## Sample Lexical Rules

(LR1.1.3.1)	V action	→→	<i>walk, run, swim,...</i>
(LR1.1.3.2)	V action causative	→→	ACTION VERB ROOT + causativiser ( <i>cause someone to do something</i> )
(LR1.1.3.3)	V action reciprocative	→→	ACTION VERB ROOT + reciprocativiser ( <i>compete with someone in doing something</i> )
(LR1.1.3.4)	V action associative	→→	ACTION VERB ROOT + associativiser ( <i>join someone in doing something</i> )
(LR1.1.3.5)	V action participative	→→	ACTION VERB ROOT + participativiser ( <i>participate with some group in doing something</i> )
(LR1.1.3.6)	V action completable	→→	<i>sing (a song), study (a lesson), give (a gift), read (a book), throw (a ball),...</i>
(LR1.1.3.7)	V action instrumental	→→	<i>use (a tool), drive (a car),...</i>
(LR1.1.3.8)	V action mensurative	→→	<i>walk (so many kilometres), run (so many kilometres),...</i>

- (LR1.1.3.9) V → *make (something out of some material),...*  
 action  
 completable  
 materiative
- (LR1.1.3.10) V → *give (a gift to someone),...*  
 action  
 completable  
 benefactive
- (LR1.1.3.11) V → *walk + associativiser (and beneficiary subject specification) (associate someone with somebody in walking),...*  
 action  
 associative  
 benefactive
- (LR1.1.3.12) V → *walk + causativiser (cause oneself to be walked by somebody),...*  
 action  
 benefactive  
 interestive
- (LR1.1.3.13) V → *walk to, go to, move towards,...*  
 action  
 directional  
 to
- (LR1.1.3.14) V → *come from, arrive from,...*  
 action  
 directional  
 from
- (LR1.1.3.15) V → *walk (with the use of some instrument, e.g., a cane), read (a book with the use of some instrument, e.g., a magnifying glass), drive (a car with the use of some instrument, e.g., gloves),...*  
 action  
 instrumentative

Some examples of maximally specified action V's:

- (LR1.1.3.16) V → *give + causativiser + reciprocativiser (compete with someone in causing somebody to give something to somebody else),...*  
 action  
 causative  
 reciprocal  
 completable  
 benefactive
- (LR1.1.3.17) V → *make + causativiser + participativiser (participate with some people in causing someone to make something out of some material)*  
 action  
 causative  
 participative  
 completable  
 materiative
- (LR1.1.3.18) V → *go to + causativiser + associativiser (associate with someone in causing someone else to go to some place for so many kilometres),...*  
 action  
 causative  
 associative  
 directional  
 to  
 mensurative

(LR1.1.3.19)	V action causative participative instrumentive	→	walk + causativiser + participativiser (and instrument subject of specification) ( <i>participate with some people in causing someone to walk; one participates using some kind of an instrument, e.g., a whip</i> ),...
--------------	--	---	---

#### 1.1.4. Process-Action Verbs

Consider the sentence:

- (1.1.4.1) púpútut yaŋ táli? # i Pédrú  
'Pedro is cutting rope.'

(pútut 'to cut', táli? 'rope', ya 'subject he'), where táli? is a patient N and Pédrú is an agent N. The patient N undergoes or 'suffers' (Latin *patior*) the process of being cut.

A process-action V may be specified as causative, in which instance an agentive beneficiary N is necessary:

- (1.1.4.2) pápapútut yaŋ tali? # kaŋ Suán # i Pédrú  
'Pedro is causing Juan to cut rope.'

where Suán is an agentive beneficiary N.

A process-action V may likewise be specified as either reciprocative or associative or participative, necessitating a plural agent N or an associate N or a plural associate N, respectively:

- (1.1.4.3) mipágpútut laŋ táli? # diŋ ának  
'The children are competing [with each other] in cutting rope.'
- (1.1.4.4) mákipútut yaŋ táli? # kaŋ Suán # i Pédrú  
'Pedro is associating [himself] with Juan in cutting rope.'
- (1.1.4.5) mákipagpútut yaŋ táli? # kariŋ ának # i Pédrú  
'Pedro is participating with the children in cutting rope.'

A process-action V which is neither reciprocative nor associative nor participative may be specified as localised, in which case it demands a location N:

- (1.1.4.6)\* tíran na ya naŋ Pédrú # kiŋ sálu? # i Suán >  
tíran neŋ Pédrú # kiŋ sálu? # i Suán  
'Juan was hit by Pedro on the chest.'

(tíran 'hit' from túran 'to hit', na 'non-subject he' co-referential with 'Pedro', ya 'subject he' co-referential with 'Juan', sálu? 'chest'), where sálu? is a location N.

Like action V's, process-action V's may be specified as instrumentative, if they are performed with the use of some instrument:

- (1.1.4.7)\* ipáŋ+pútut na ya+ŋ táli? naŋ Pédrú # iŋ guntíŋ >  
 pámutut neŋ táliŋ Pédrú # iŋ guntíŋ  
 'The scissors (lit. the scissor) are being used by  
 Pedro to cut rope with.'

where guntíŋ is an instrument N.

A process-action V must be specified as reflexive as its patient N and its agent N are co-referential:

- (1.1.4.8)\* pá+patáy+an na ya naŋ Pédrú # iŋ saríli na >  
 pápatén neŋ Pédrú # iŋ saríli na  
 'His self is being killed by Pedro.' =  
 'Pedro is killing himself.'

(patén 'to kill' (lit. die + causativiser) from \*matáy > patáy+an, saríli 'self', na 'his'). In sentences such as 1.1.4.8, both patient N and agent N are lexically specified by Pédrú; the root of the patient N is deleted and 'self' is introduced post-semantically. There is another way of expressing 'Pedro is killing himself':

- (1.1.4.8a) mágpakamaté ya # i Pédrú  
 'Pedro is committing suicide.'

where the lexical analysis of V is die + exertiviser + causativiser (paka- 'exertiviser', mag- 'causativiser'), literally, 'to exert [one-self] in killing'. Perhaps it is better to consider magpakamaté as an idiom 'to commit suicide'. A related V root is:

- (1.1.4.9)\* pá+i+matáy ya # kiŋ álak # i Pédrú >  
 páimaté ya # kiŋ álak # i Pédrú  
 'Pedro is causing himself to be killed by alcoholic  
 beverages.' = 'Pedro is drinking himself to death.'

where Pédrú is both agent and patient and where álak 'alcoholic beverage' is an instrument N. The affix combination \*pa+i- is restricted to the root \*matáy and would have to be accounted for by a special lexical rule. In the rules on process-action V's which will be formulated, neither magpakamaté nor paimaté will be considered.

In summary, a non-state V may be specified as process-action. A process-action V may be specified as causative and/or reciprocative, associative, or participative. A process-action V which is neither reciprocative nor associative nor participative may be specified as localised. Moreover, any process-action may be specified as instrumentative if it is performed with the use of some instrument. Finally, process-action V's in which the agent N and the patient N are co-referential must be specified as reflexive.

Process-action V's demand both an agent N and a patient N; in addition, a causative process-action V demands an agentive beneficiary N; an associative process-action V demands an associate N; a reciprocal process-action V demands a plural agent N; a participative process-action V demands a plural associate N; localised process-action V's demand a location N; instrumentative process-action V's demand an instrument N.

Process-action V's may be accompanied by other N's in addition to those stipulated thus far, in surface structure. Such accompanying N's (for example, time N's, other location N's, motive N's) will be treated in Chapter III as traceable in semantic structure to separate V's.

The following rules state the generalisations on process-action V's:

- (Sl.1.4.1') V -state  $\rightarrow$  process action
- (Sl.1.4.2') V process action  $\rightarrow$   $\left( \begin{array}{l} \text{causative} \\ \left\{ \begin{array}{l} \text{reciprocalive} \\ \text{associative} \end{array} \right\} \\ \left\{ \begin{array}{l} \text{participative} \end{array} \right\} \\ \text{localised} \end{array} \right)$
- (Sl.1.4.3') V process action  $\rightarrow$  instrumentative
- (Sl.1.4.4') V process action  $\rightarrow$  reflexive /  $\begin{array}{l} \text{patient} \\ N_1 \end{array}$   $\begin{array}{l} \text{agent} \\ N_1 \end{array}$
- (Sl.1.4.5') V causative  $\rightarrow$   $\begin{array}{l} \text{agentive} \\ \text{beneficiary} \\ N \end{array}$   
V causative
- (Sl.1.4.6') V { associative participative }  $\rightarrow$   $\begin{array}{l} \text{associate} \\ N \end{array}$   
{ associative } <participative> <plural>
- (Sl.1.4.7') V localised  $\rightarrow$   $\begin{array}{l} \text{location} \\ N \end{array}$   
V localised
- (Sl.1.4.8') V process  $\rightarrow$   $\begin{array}{l} \text{patient} \\ N \end{array}$   
V process

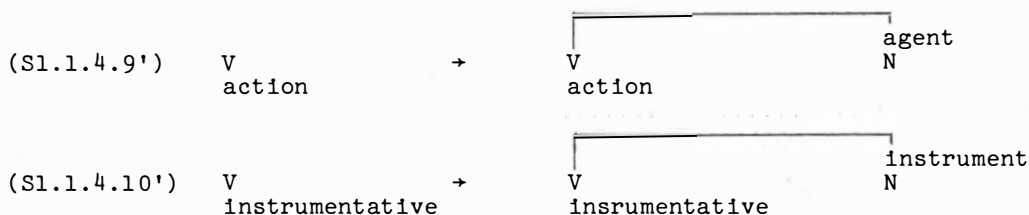

## Sample Lexical Rules

- (LR1.1.4.1) V  
process  
action → *cut, kill, chew,...*
- (LR1.1.4.2) V  
process  
action  
causative → PROCESS-ACTION VERB ROOT +  
causativiser (*cause someone to do  
something to somebody or to  
something*)
- (LR1.1.4.3) V  
process  
action  
reciprocal → PROCESS-ACTION VERB ROOT +  
reciprocativiser (*compete with  
someone in doing something to  
somebody or to something*)
- (LR1.1.4.4) V  
process  
action  
associative → PROCESS-ACTION VERB ROOT +  
associativiser (*join someone in  
doing something to somebody or  
to something*)
- (LR1.1.4.5) V  
process  
action  
participative → PROCESS-ACTION VERB ROOT +  
participativiser (*join a group  
in doing something to somebody  
or to something*)
- (LR1.1.4.6) V  
process  
action  
localised → *hurt (somebody in some part  
of the body),...*
- (LR1.1.4.7) V  
process  
instrumentative → *cut (with some instrument),  
kill (with some instrument),...*
- (LR1.1.4.8) V  
process  
action  
reflexive → *kill oneself, cut oneself,...*

Some maximally specified process-action V's:

- (LR1.1.4.9) V  
process  
action  
causative  
localised  
instrumentative → *hit + causativiser (and instrument  
subject specification) (cause  
someone to hit someone else in some  
part of the body; one causes this  
using some instrument)*

(LR1.1.4.10)	V	→→	kill + causativiser + reciprocativiser
	process		( <i>compete with someone in causing</i>
	action		<i>someone else to kill somebody or</i>
	causative		<i>something</i> )
	reciprocative		

### 1.1.5. Other Verb Specifications

Action V's and process-action V's may be further specified by other selectional units before V is finally narrowed down to a lexical choice (which is either a basic root or more often a derived root with affixes). The two selectional units to be described in section 1.1.5.1 were not discussed in the preceding sections because unlike the selectional units discussed earlier, these two units merely add semantic content to the root without stipulating accompanying N's.

Moreover, certain verbs demand that a selectional unit be present in their accompanying N's; mention has already been made of plural specification for certain N's accompanying V. Plural specification is inflectional. In addition, experiential V's demand an experiencer N that is selectionally animate; action V's demand an agent N that is selectionally potent. A few of these specifications will be treated in section 1.1.5.2.

#### 1.1.5.1. Other Selectional Units of Action and Process-Action V's.

Action and process-action V's may be further specified as exertive or unintentional; the two specifications are mutually exclusive. Moreover, the unit 'unintentional' is incompatible with selectional units which connote deliberateness; hence, it is likewise in exclusive disjunction with reciprocative, associative, and participative, but not with causative.

(1.1.5.1.1)\* páka+lákad na naŋ Pédrú >  
 páka+lákad naŋ Pédrú  
 'Pedro exerts [himself] in walking.'

(pákálákad 'to exert [oneself] in walking' (lit. walk + exertiviser), na 'non-subject he'), in which there is no subject N.

(1.1.5.1.2) mípalákad ya # i Pédrú  
 'Pedro unintentionally walked.'

(mípalákad 'to walk unintentionally' (lit. walk + unintentionaliser)).

By way of example, the different derivational affixes which may occur with a root (an action V) will be shown using the root *lákad* 'walk' (the accentual patterns signal unmarked or -actual aspect):

	lákad	'to walk'
	pa+lákad	'to cause to walk'
	paká+pa+lákad	'to exert oneself in causing to walk'
mipag+	paká+pa+lákad	'to compete in exerting oneself in causing to walk'
makit+	paká+pa+lákad	'to join in exerting oneself in causing to walk'
makipag+	paká+pa+lákad	'to participate in exerting oneself in causing to walk'
mipa+	pa+lákad	'to unintentionally cause someone to walk'

The lexical choice of the V root is subsequent to selectional specification. It should be repeated that the two selectional units 'exertive' and 'unintentional' make no stipulations concerning accompanying N's, whereas the units 'causative', 'reciprocative', 'associative', and 'participative' do. On the other hand, such V selectional units as 'completable', 'instrumental', 'materiative', and the like, although they make stipulations on accompanying N's, are not specified by derivational lexical units and hence receive no symbolisation. The selectional unit 'instrumentative' receives no lexical symbolisation but demands that its accompanying instrument N be subjectivised. This subjectivisation process is mirrored in the verb root by an incorporation rule which specifies the verb root inflectionally as 'instrument subject'; this specification is eventually symbolised by the prefix ipaŋ-

#### 1.1.5.2. N Selectional Specifications from V Selectional Specifications

Besides the selectional specifications already described, all V's demand further specifications with regard to the selectional units their accompanying N's must have. For example, it has already been stated that experiential V's, state or process, demand an animate experiencer N. This requirement may be formulated by a rule such as the following:

(S1.1.5.2.1') V → animate experiencer  
experiential

(S1.1.5.2.2') V → 

V		experiencer
V		N
experiential	experiential	animate

This rule would then be a modification of the pertinent replacement rules for experiential V's already formulated. Since the theory places no constraints on the number of symbols or specifications which may be replaced by a rule, the second formulation will be adopted and N selectional unit requirements will be incorporated into the replacement rules, in the section on Restatement of Rules.

Again, action V's demand a potent agent, an agent capable of effecting an action; it was earlier stated that abilitative state V's demand a potent patient, a patient that is potentially an agent. Causative V's demand a human agent and an animate agentive beneficiary. Benefactive action V's demand an animate agent, although the beneficiary N need not be either human or animate. Material N's are intrinsically -animate.

Actually, these N selectional specifications demanded by certain V's are most likely universal, because imposed on us by our knowledge of the external world. It is debatable, therefore, whether such specifications should be treated in linguistics at all (for a succinct statement of the problem arising from 'knowledge of the language' and 'knowledge of the world', see Bolinger 1965; for opinions against treating such specifications in a grammar, see McCawley 1968a and Fillmore [undated]). In any case, if considered as legitimate subject matter for a theory of language, such specification rules are more economically treated as language universal redundancy rules or semantic marking conventions. Whatever specifications are discovered to be language-specific would have to be formulated separately, of course. It is in this section of a semantic description that such specifications should be described formally.

#### 1.1.6. Summary of $\overline{V-N}$ Relations and Re-statement of Rules.

In this section, the roles which co-occurring N's assume with regard to V, the different N relations, will be summarised. Then, rules either formulated in sections 1.1.1 to 1.1.5 (excluding Lexical Rules) will be conflated and re-stated.

##### 1.1.6.1. $\overline{V-N}$ Relations

Pampangan role-marked N's may be divided into two main classes according to the type of determiner which occurs with them ( $na\eta/ni\eta$  or  $ka\eta/ki\eta$ ) when they are not subjectivised ( $i/i\eta$ ).

The following role-marked N's, when non-subjectivised, are marked by  $na\eta/ni\eta$  unless special post-semantic processes intervene:

AGENT	=	the actor or the efficient cause; the instigator of a causative action
COMPLEMENT	=	that which completes the meaning of an action; in verbs of making, the product or artifact
EXPERIENCER	=	the subject of sentient experience
INSTRUMENT	=	that with which or by means of which something is done
MEASURE	=	that which quantifies the extent of some state or event

PATIENT = the undergoer or sufferer of physical change; the stimulus of sensation; that which is present in a situation (hence, the usual accompaniment of state V's)

The following role-marked N's when non-subjectivised, are marked by kaŋ/kiŋ unless special post-semantic processes intervene:

ASSOCIATE = that with which another N is joined or associated  
 AGENTIVE  
 BENEFICIARY = the recipient of a causative action; occurs only with an (instigative) agent  
 BENEFICIARY = the recipient of benefits or misfortunes  
 GOAL = the place to which movement is directed  
 LOCATION = the place in which a situation or an event occurs  
 MATERIAL = that out of which something is made  
 MOTIVE = the final cause or reason for an event or situation; the occasion for an event or situation  
 NORM = the standard against which something is equated or compared  
 PARTITIVE = the whole in a part-whole relation  
 SOURCE = the place from which movement begins  
 TIME = the period or instant in which a situation or an event occurs

A case can be made for distinguishing PATIENT further by positing a genuine patient, that which undergoes or suffers physical change, and an object, that which is present in a situation or an event but which does not undergo any physical change. If such a distinction is adopted, then most state V's would be accompanied not by a patient N but by an object N. Initially, this distinction was made in the course of the investigation. It was found, however, that in Pampangan, the differentiation was without consequences for later post-semantic processes; to simplify the rules, therefore, patient and object have been conflated into PATIENT.

Pampangan clearly distinguishes between an instigator, in the list, an AGENT, and a motive or reason or occasion, in the list, a MOTIVE. Hence, the term which more readily comes to mind, CAUSE, was studiously avoided as an N relation, since an instigator and a motive in many ways can be considered as causes.

Again, a case can be made for considering a BENEFICIARY a kind of GOAL; however, in cases of possession, where a BENEFICIARY is clearly present, no movement is pre-supposed. GOAL has therefore been reserved for locational terminal points.

The AGENTIVE BENEFICIARY is both an agent in its own right as well as a recipient of a causative action; it must be distinguished from ordinary BENEFICIARY, however, since it is possible to cause someone to give

something to somebody. The marking of AGENTIVE BENEFICIARY when non-subject by *kaṅ/kiṅ* prompted the choice of the label 'AGENTIVE BENEFICIARY'.

The list of role-marked N's set down may be added to as more V types are investigated. Obviously, certain similarities and parallelisms may be easily discovered, which would motivate one to reduce the inventory. In verbs of making, for example, material N may be considered a source N and the complement (or product) a goal N; in the list set down, however, source and goal are used only in connection with places. Moreover, there are certain similarities between patient and goal, for example, in verbs of contact such as '*hit*'; hence, Pāṇini subsumes product, patient, and goal under *karma* (see Ananthanarayana 1969 and Kiparsky and Staal 1969). The fact too that certain N relations occur only with certain V's would lead one to suspect that the differentiation of roles may be a function of the semantic specification of V; perhaps, these different relations may be reducible to a few 'case primitives' (to use Fillmore's term), each primitive being specified further through its co-occurrence with a particular V type.

Until more is known about these N relations, however, the safer strategy is to posit as many relations as seem necessary, always keeping in mind that eventually each language reduces these relationships into a smaller number of types in surface structure (in Pampangan, into three types). For purposes of this study, the above list will be used.

#### 1.1.6.2. *Re-statement of Rules*

The rules to be set down below conflate the rules earlier formulated in sections 1.1.1 to 1.1.5. As the rules are formulated, ordering is essential, especially for the replacement rules which state which N relation accompanies a particular V specification. The configurations which result will be used as bases of certain subjectivisation rules which will be discussed in Chapter II. Although several units specify more than one sub-type of V (state, process, action, process-action), in the re-statement of rules, these units are specified separately for each sub-type, since the co-occurrence restrictions of these units are not the same for each sub-type. Thus, although the unit benefactive may specify a state, a process, or an action V, the specification rule for each sub-type of V is separate, since the co-occurrence restrictions of the unit 'benefactive' vis-à-vis other specifications are different for each sub-type of V. In state V's as well as in process V's, the unit 'benefactive' is in a relation of exclusive disjunction with other specifications of state and process V's; on the other hand, the unit 'benefactive' may co-occur with other selectional units in action V's.

Hence, the economy which may obtain as a result of conflating the specification rule for 'benefactive' with regard to state, process, and action V's is offset by the necessary restrictions that would have to be stated in the rule for each sub-type of V.

(S1.1) 
$$V \rightarrow \left\{ \begin{array}{l} \text{state} \\ \text{process} \\ \text{action} \end{array} \right\}$$

(S1.2) 
$$V \text{ state} \dashrightarrow \left[ \begin{array}{l} \text{ambient} \\ \text{localised} \\ \text{abilitative} \\ \text{mensurative} \\ \text{motivative} \\ \text{experiential} \\ \text{presential} \\ \text{directional} \\ \text{habitive} \\ \text{necessitative} \\ \text{associative} \\ \text{similaritative} \\ \text{possessive} \\ \text{intentive} \\ \text{favouritive} \\ \text{locative} \\ \text{temporal} \\ \text{partitive} \end{array} \right]$$

(S1.3) 
$$\begin{array}{l} V \\ \text{state} \\ \text{(mensurative)} \\ \text{-other} \\ \text{specifications} \\ \text{root} \end{array} \dashrightarrow \left\{ \begin{array}{l} \text{equative} \\ \text{comparative} \\ \text{superlative} \end{array} \right\}$$

(S1.4) 
$$V \text{ process} \dashrightarrow \left[ \begin{array}{l} \text{ambient} \\ \text{localised} \\ \text{mensurative} \\ \text{benefactive} \\ \text{habitive} \\ \text{necessitative} \\ \text{experiential} \end{array} \right]$$

(S1.5) 
$$V \text{ action} \dashrightarrow \left( \begin{array}{l} \text{causative} \\ \text{exertive} \\ \left\{ \begin{array}{l} \text{reciprocatative} \\ \text{associative} \\ \text{participative} \\ \text{unintentional} \end{array} \right\} / V \\ \text{-exertive} \\ \left\{ \begin{array}{l} \text{completable} \\ \text{instrumental} \\ \text{mensurative} \end{array} \right\} / V \\ \text{-completable} \end{array} \right)$$

- (S1.6) V action - → benefactive  
 {completable,  
 associative}
- (S1.7) V action - → materiative  
 completable
- (S1.8) V action - → directional  
 -benefactive  
 -materiative
- (S1.9) directional → { to }  
 { from }
- (S1.10) V process - → (causative  
 exertive  
 {reciprocative  
 associative  
 participative / V  
 unintentional -exertive}  
 action }  
 localised
- (S1.11) V (process) - → instrumentative  
 action
- (S1.12) V completable → V completable complement  
 N
- (S1.13) V instrumental → V instrumental instrument  
 N
- (S1.14) V mensurative → V mensurative measure  
 N
- (S1.15) V materiative → V materiative material  
 N
- (S1.16) V associative → V associate  
 participative { <participative> } N  
 <plural>

- (S1.17) V → V norm  
N  
{similaritative} {similaritative}  
{equatative} {equatative}  
{comparative} {comparative}
- (S1.18) V → V partitive  
N  
{partitive} {partitive}  
{superlative} <superlative> <plural>  
<total >
- (S1.19) V → V location  
N partitive  
{localised} {localised}  
{presential} {presential}  
{locative} {locative}

This rule is optional for

V  
state  
presential

- (S1.20) V → V goal  
N  
directional directional  
to to
- (S1.21) V → V source  
N  
directional directional  
from from
- (S1.22) V → V time  
N  
temporal temporal
- (S1.23) V → V patient  
N  
{state} {state}  
{(abilitative)} {<(abilitative)>} <potent>  
{process} {process}
- ambient -ambient

This rule is optional for

V and  
state  
motivative

does not apply to V  
process  
habitive



to be described in this section and then stored in the lexicon, as it were, and made available as lexical units which may be selected to specify V after V has been specified previously by selectional units.

The V derivational processes are of two types. Some processes are purely additive, a derivational unit being added to a root without changing the root into an N or into some other sub-type of V. The process may be described in general thus:

$$\begin{array}{ccc}
 V & \rightarrow & V \\
 \left\{ \begin{array}{l} \text{state} \\ \text{process} \\ \text{(action)} \end{array} \right\} & & \left\{ \begin{array}{l} \text{state} \\ \text{process} \\ \text{(action)} \end{array} \right\} \\
 \text{root} & & \text{root + derivational affix}
 \end{array}$$

Examples of derived forms generated by a process of this type have already been given in section 1.1.5, using *lákad* 'to walk' as a root. Such units as 'reciprocativiser', 'associativiser', 'participativiser', 'unintentionalizer', and 'exertiviser' are derivational units added to a V root; they add meaning to the root but do not change its categorisation or sub-categorisation. Much more interesting is the second type of V derivational process, a process which changes the categorisation of a root by making V into N or a process which changes the sub-categorisation of a root by making a sub-type of V into another sub-type. Such processes, besides changing categorisation or sub-categorisation, likewise add meaning to the root. It is with processes of the second type that this section will deal.

#### 1.1.7.1. State Verbs: Derivational Processes

##### 1.1.7.1.1. State Verbs to Process Verbs

Consider the sentence:

(1.1.7.1.1.1) *báyu ya # lη balé*  
'The house is new.'

One may likewise say:

(1.1.7.1.1.2) *máginbáyu ya # iη balé*  
'The house is becoming new.'

where the V, inflected for actual durative aspect, is analysable semantically as *new* + *fierientiser* from Latin *fieri* 'to become') and where the derivational rule (hereinafter DR) operative is:

$$\begin{array}{ccc}
 \text{(DR 1')} & V & \rightarrow & V \\
 & \text{state} & & \text{process} \\
 & \text{root} & & \text{root + fierientiser}
 \end{array}$$

Still another possible derivation is:

- (1.1.7.1.1.3) mágbáyu ya # i Maryá  
'*Maria is turning into a new person.*'

where the verb is analysable semantically as *new* + *vertitiviser* and where the operative derivational rule is:

- |         |       |    |                     |
|---------|-------|----|---------------------|
| (DR 2') | V     | -> | V                   |
|         | state |    | process             |
|         | root  |    | root + vertitiviser |

It is difficult to pinpoint the difference between mágiṅbáyu '*becoming new*' and mágbáyu '*turning new*'. *magiṅ-* can be used for becoming of any kind. It freely combines with noun roots:

- (1.1.7.1.1.4) mágiṅdóktór ya # i Pédro  
'*Pedro is becoming a doctor.*'

*magiṅ-* is thus a general marker for becoming, some uses of which match those of *mag-*.

#### 1.1.7.1.2. State Verbs to Action Verbs

From *báyu* '*new*', one can have:

- (1.1.7.1.2.1) mágbáyu ya # i Maryá

The sentence is ambiguous. It may mean '*Maria is becoming a new person*' (as in 1.1.7.1.1.3) or it may mean '*Maria is making things new*'. In the second meaning, *mágbáyu* is an action V and *Maryá* is its accompanying agent N. The derivational rule relevant to the second meaning is:

- |         |       |    |                      |
|---------|-------|----|----------------------|
| (DR 3') | V     | -> | V                    |
|         | state |    | action               |
|         | root  |    | root + activativiser |

The derived verb root *magbáyu* '*to make new*' may become once more a state V:

- (1.1.7.1.2.2) mapágbáyu ya # i Maryá  
'*Maria is inclined to make [things] new.*' =  
'*Maria believes in planned obsolescence (!).*'

where the state V is analysable as *new* + *activativiser* + *inclinativiser*. The rule for deriving a state V from an action V will be formulated in the pertinent section.

#### 1.1.7.1.3. State Verbs to Process-Action Verbs

From state V *báyu* '*new*', one may derive:

- (1.1.7.1.3.1) mágbáyu yaŋ átu # i Maryá  
'*Maria is changing car(s).*'

The V is analysable as *new* + *activativiser* + *processiviser*; in other words, to derive a state V into a process-action V, no new derivational rule need be formulated. DR 3' has to be applied; then a rule converting an action V into a process-action V has to be applied. This latter rule will be formulated in the pertinent section.

#### 1.1.7.1.4. State Verbs to Derived Nouns

An inherent state V such as *báyu* 'new' may be derived into *kabáyuan* ~ *kabayuán* 'newness'. A term such as *kabáyuan* may be considered a nominalised form of the state V *báyu* 'new':

- (1.1.7.1.4.1) báyu ya # iŋ átu ##  
masantŋ # iŋ kabáyuan na niŋ átu  
'*The car is new.*'  
'*The newness of the car is pleasing.*'

Hence, the discontinuous morph *ka-...-an* is a symbolisation for *nomin-aliser*. *Nominalisers* for each sub-type of V will be postulated. Hence, a numerical subscript will be added to *nominaliser* to indicate its particular sub-type:

(DR 4')	V	- →	N
	state		abstract
	root		root + nominaliser <sub>1</sub>

It should be stated at this point that the process of nominalisation is a grammatical process (to be discussed in Chapter IV); the output of such a process includes a form, *root + nominaliser<sub>1</sub>*, a lexical item generated by a previous derivational process (DR 4'). It is only with the generation of nominalised forms (lexical items) and not with the process of nominalisation itself that this section deals.

#### 1.1.7.2. Process Verbs: Derivational Processes

##### 1.1.7.2.1. Process Verbs to State Verbs

From *dágu* 'to grow', an inherent process V, one may have the following:

- (1.1.7.2.1.1) dáragúl ya # iŋ anák  
'*The child is growing [big].*'

Once the child has grown, one can say:

- (1.1.7.2.1.2) méragúl ya # iŋ anák  
'*The child has grown.*'

where the process-turned-state V is analysable as *grow* + *resultativiser*. The derivational rule may be formulated thus:

(DR 5')	V	-->	V
	process		state
	root		root + resultativiser

#### 1.1.7.2.2. Process Verbs to Process-Action Verbs

In the sentence:

- (1.1.7.2.2.1) páragúl yaṅ anák # i Pédrú  
*'Pedro is causing a child to grow.'* =  
*'Pedro is raising a child.'*

the process-action verb is *grow* + *causativiser*; *anák* is a patient N and *Pédrú* is an agent N. The derived process-action V, like any process-action V, may be selectionally specified as causative, in which instance it demands both an agent N and an agentive beneficiary N:

- (1.1.7.2.2.2) pápáparagúl yaṅ anák # kaṅ Suán # i Pédrú  
*'Pedro is causing Juan to raise children.'*

Note that the verb root has two prefixes (the initial *pa-* is a result of re-duplication for aspect), *pa-* to symbolise causative specification of the process-action V, *-pa-* to symbolise the derivational unit *causativiser* which converted the process V into a process-action V. Thus, the analysis of V is *grow* + *causativiser*<sub>1</sub> + *causativiser*<sub>2</sub>. The derivational rule may be formulated thus:

(DR 6')	V	-->	V
	process		process action
	root		root + causativiser <sub>1</sub>

#### 1.1.7.2.3. Process Verbs to Action Verbs

In the sentence

- (1.1.7.2.3.1) páragúl ya # i Pédrú  
*'Pedro is causing [something] to grow.'*

a patient N is pre-supposed but not expressed. There seems to be no direct derivational path from process V to action V, since a process V necessarily demands a patient N, a patient N which is missing in the above example. The more plausible path of derivation is from process V to process-action V (DR 6'), which introduces an agent N; then the process-action V may undergo a second derivation to make it an action V. This latter rule will be formulated in the pertinent section.

## 1.1.7.2.4. Process Verbs to Derived Nouns

Consider the two sentences:

- (1.1.7.2.4.1) dáragúl ya # iṅ anák ##  
 mákayáma # iṅ páṅaragúl na niṅ anák  
 'The child is growing.'  
 'The growing of the child is admirable.'

The subject phrase of the second sentence (marked iṅ) is a nominalisation of the first sentence. The derivation of the noun root may be formulated thus:

(DR 7')	V	->	N
	process		abstract
	root		root + nominaliser <sub>2</sub>

There are two other derived N's from dágul 'to grow':

- (1.1.7.2.4.2) makanánu # iṅ karagulán na niṅ anák  
 'How is the growth of the child?'
- (1.1.7.2.4.3) nánu # iṅ dagúl na niṅ sapátus mu  
 'What is the size of your shoe?'

where \*ka+dágul+an means 'growth' and dagúl means 'size'. To account for karagulán, distinct from páṅaragúl 'process of growing', a nominalised form, the following derivational process would have to be formulated:

(DR 8')	V	->	N
	process		abstract
	root		root + abstractiviser <sub>2</sub>

The numerical subscript for abstractiviser is necessary, since another abstractiviser (for state V's) will be postulated. In the case of dagúl 'size', however, it seems that the derived N is not from a process V but from a state V - it designates the measure of the result of growth. Another state V to abstract N process must be formulated, therefore:

(DR 4a')	V	->	N
	state		abstract
	root		root + abstractiviser <sub>1</sub>

where the input root may be a derived root from a previous derivational process.

It should be noted that there seems to be asymmetry in the symbolisation of the nominalisers and abstractivisers. The symbolisation for a state V nominaliser is usually ka-...-an. On the other hand, the usual symbolisation for a process V nominaliser is paṅa-. There is an abstractiviser for process V's, however, which has the symbol-

isation ka-...-an, homophonous with the state V nominaliser. The symbolisation for the state V abstractiviser consists of an accentual shift: *dágu!* > *dagú!*.

In turn, the derived noun root *dagú!* 'size' may undergo a noun to state V derivation (rules for which will be formulated in section 2.2): \*ma+*dagú!* > *maragú!* 'big' (lit. *size* + plenitiviser).

### 1.1.7.3. Action Verbs: Derivational Processes

#### 1.1.7.3.1. Action Verbs to State Verbs

In the sentence:

- (1.1.7.3.1.1) *palákad ya # i Pédrú*  
                   '*Pedro is inclined to walk.*' =  
                   '*Pedro is a rover.*'

the state V \**pala+lákad* 'inclined to walk' (lit. *walk* + *inclinativiser*<sub>1</sub>) is derived from inherent action V *lákad* 'walk'. *pala-* is only one among many possible derivational units which de-activate an action V and convert it into a state V. Again, one may say:

- (1.1.7.3.1.2)\* *ka lákad na ya naŋ Pédrú # i Suán >*  
                   *kalákad neŋ Pédrú # i Suán*  
                   '*Juan is in the company of Pedro in walking.*'

where the state V is analysable as *walk* + *stative associativiser*; the latter unit is symbolised by *ka-* and is to be distinguished from (non-stative) *associativiser* *maki-*, which combines with action verb roots but does not change their sub-categorisation, as in *makilákad* 'to join in walking'.

Another productive derivational unit is 'abilitative':

- (1.1.7.3.1.3) *mákalákad ya # i Pédrú ~*  
                   *milalákad ya # i Pédrú*  
                   '*Pedro is able to walk.*'

Tentatively, *maka-* will be distinguished from *mi-* as being a different kind of *abilitativiser*, hence, *abilitativiser*<sub>1</sub> and *abilitativiser*<sub>2</sub>. The semantic distinction between them is difficult to characterise. In *mákalákad*, the meaning is 'able to walk' in the sense of being able to go, for example, on many errands because of time off; in *milalákad*, the meaning is 'able to walk' in the sense of physical ability, for example, predicated of someone who is convalescing. However, *abilitativiser*<sub>1</sub> may likewise be used in the latter context. Moreover, certain verb roots select only *maka-*: *mákapútut* 'able to cut' but not <sup>x</sup>*mipupútut*. *maka-* and *mi-* are unusual in that state V's in which these affixes

occur can be inflectionally specified for aspect, unlike other state V's. The derivational rule pertinent to this section may be formulated thus:

(DR 9')	V	- →	V
	action		state
	root		root + $\left. \begin{array}{l} \text{inclinativiser}_{1,2} \\ \text{stative associativiser} \\ \text{abilitativiser}_{1,2} \end{array} \right\}$

#### 1.1.7.3.2. Action Verbs to Process-Action Verbs

This derivational process is problematic, since in many instances, what appears to be a process-action V is actually a completable, instrumental, or mensurative action V. In the following sentence, however, there is clearly a patient N:

(1.1.7.3.2.1)\* *la+lákad+an na la naη Pédrú # diη úbas >*  
*lalakáran na laη Pédrú # diη úbas*  
*'The grapes are being trampled on by Pedro.'*

(na 'non-subject he', la 'subject they' co-referential with 'grapes', úbas 'grape' from Spanish uvas 'grapes' preceded by the plural subject determiner diη). If úbas were a location N instead of a patient N, one would say:

(1.1.7.3.2.2) *lálákad ya # i Pédrú # kariη úbas*  
*'Pedro is walking among the grape [vines].'*

The derivational process may be described thus:

(DR 10')	V	- →	V
	action		process action
	root		root + processiviser

#### 1.1.7.3.3. Action Verbs to Process Verbs

There does not seem to be a direct derivational path from action to process V's, since process V's pre-suppose a patient N while inherent action V's have no patients. It is possible to say:

(1.1.7.3.3.1) *malalákad la # diη úbas*  
*'The grapes are being trampled on.'*

but this is an instance of a process-action V becoming a process V; the derivation process for this will be formulated in the pertinent section.

#### 1.1.7.3.4. Action Verbs to Derived Nouns

Consider the sentence pair:

(1.1.7.3.4.1) lálákad ya # i Pédrú ##

\*ma+dayú? # iη pámanlákad na naη Pédrú >

márayú? # iη pámanlákad naη Pédrú

'Pedro is walking.'

'The walking by Pedro is far.'

(\*ma+dayú? 'far' (lit. *distance* + plenitiviser)), where pámanlákad is analysable as *walk* + nominaliser<sub>3</sub>. pámanlákad' is likewise a symbolisation for 'manner of walking':

(1.1.7.3.4.2)\* máka+túla? # iη pámanlákad na naη Pédrú >

mákatúla? # iη pámanlákad naη Pédrú

'Pedro's manner of walking is motivative of laughter.'

where pámanlákad is analysable as *walk* + modaliser.

Again, in addition to lákad<sub>1</sub> 'to walk', one may likewise have lákad<sub>2</sub> 'trip, journey', which is semantically analysable as *walk* + complementiser. The label 'complementiser' is fitting insofar as the noun completes the meaning of the verb: 'to walk a walk'. One may likewise use lákad<sub>3</sub> to mean 'manner of walking'. The following examples will clarify the above observations:

(1.1.7.3.4.3)\* ma+kába? # iη lákad na naη Pédrú >

makába? # iη lákad naη Pédrú

'Pedro's trip is long.'

(1.1.7.3.4.4)\* máka+túla? # iη lákad na naη Pédrú >

mákatúla? # iη lákad naη Pédrú

'Pedro's manner of walking is motivative of laughter.'

It seems that lákad<sub>3</sub> is a variant symbolisation for pámanlákad<sub>2</sub>. The following rule may be formulated:

(DR 11')	V	-->	N
	action		abstract
	root		root +
			{ <div style="display: inline-block; vertical-align: middle; margin: 0 5px;">           nominaliser<sub>3</sub>            modaliser            complementiser         </div> }

#### 1.1.7.4. Process-Action Verbs: Derivational Processes

##### 1.1.7.4.1. Process-Action Verbs to Action Verbs

From the sentence:

(1.1.7.4.1.1) púpútut yaη dútuη # i Pédrú

'Pedro is cutting wood.'

one may have:

- (1.1.7.4.1.2) púpútut ya # i Pédrú  
'Pedro is cutting.'

which necessitates the following derivational rule:

(DR 12')	V	->	V
	process		action
	action		
	root		root + deprocessiviser

#### 1.1.7.4.2. Process-Action Verbs to Process Verbs

Consider the sentence:

- (1.1.7.4.2.1) mapupútut ya # in dútuŋ  
'The [piece of] wood is being cut.'  
'The [piece of] wood is apt for cutting.'

In the first meaning, the relevant derivational rule is:

(DR 13')	V	->	V
	process		process
	action		
	root		root + de-causativiser

In the second meaning, it seems that to the derived root *cut* + *de-causativiser* is added another derivational unit, *aptativiser*, which converts the process V into a state V. Thus, DR 5' should be added to thus:

(DR 5a')	V	->	V
	process		state
	root		root + aptativiser

The eventual symbolisation of *aptativiser* is  $\emptyset$ .

#### 1.1.7.4.3. Process-Action Verbs to State Verbs

Semantically related to

- (1.1.7.4.3.1) mapupútut ya # in dútuŋ  
'The [piece of] wood is being cut.'

is the sentence

- (1.1.7.4.3.2) putút ya # in dútuŋ  
'The [piece of] wood is cut.'

where the state V is a derived verb root: *cut* + *de-causativiser* + *resultativiser*. For such a derivation, no new rules need be postulated; the derived root is the output of DR 13' and DR 5'. However, there are instances of a state V derived directly from a process-action V:

- (1.1.7.4.3.3) mapágpútut yaŋ dútuŋ # i Pédrú  
*'Pedro is inclined to cut wood.'* =  
*'Pedro cuts wood often.'*

where V is *cut* + *inclinativiser*<sub>2</sub>. Or:

- (1.1.7.4.3.4) palapútut yaŋ dútuŋ # i Pédrú  
*'Pedro is naturally inclined to cut wood.'*

where V is *cut* + *inclinativiser*<sub>1</sub>. One may likewise say:

- (1.1.7.4.3.5) mákapútut yaŋ dútuŋ # i Pédrú  
*'Pedro is able to cut wood.'*

where V is *cut* + *abilitativiser*<sub>1</sub>. The process may be described thus:

(DR 14')	V	→	V
	process		state
	action		
	root		root +
			}
			{ inclinativiser <sub>1, 2</sub> abilitativiser <sub>1</sub>

From an inherent process-action V root such as *ladláð* 'to lay out', one may have the sentence:

- (1.1.7.4.3.6) makaladláð ya # iŋ kulambú?  
*'The mosquito-net is laid out.'*

It seems, however, that the derived state V *makaladláð*, analysable as *lay out* + *de-causativiser* + *positionaliser*, is not directly derived from a process-action V but from a process V. Hence, no new rule need be formulated, but an additional derivational unit must be added to DR 5':

(DR 5b')	V	→	V
	process		state
	root		root + <i>positionaliser</i>

#### 1.1.7.4.4. Process-Action Verbs to Derived Nouns

Consider the sentence pair:

- (1.1.4.4.1) púpútut yaŋ dútuŋ # i Pédrú  
 \* *ma+bágal* # iŋ pá+mag+pútut naŋ dútuŋ naŋ Pédrú >  
*mabágal* # iŋ pámagpútut naŋ dútuŋ Pédrú  
*'Pedro is cutting wood.'*  
*'The cutting [of] wood by Pedro is slow.'*

(\**ma+bágal* 'slow' (lit. *slowness* + *plenitiviser*)), where *pámagpútut* is analysable as *cut* + *nominaliser*<sub>4</sub>. The derivational process may be formulated thus:

(DR 15')	V process action  root	->	V abstract  root + nominaliser <sub>4</sub>
----------	------------------------------------	----	--

From pútut 'to cut', one may likewise have the noun kapútut 'a slice':

(1.1.7.4.4.2) méñan yañ kapútut mangá # i Pédro  
'Pedro ate a slice of mango.'

(méñan 'ate' from \*mañ+kán 'to eat', mangá 'mango'). It seems that the analysis of kapútut should be *cut* + *de-causativiser* + *resultativiser* + *singulary counter*. Hence, the derived noun is directly traceable to a state V rather than a process-action V. A state V to -abstract N rule should be formulated therefore:

(DR 4b')	V state  root	->	N -abstract  root + singulary counter
----------	------------------------	----	--

#### 1.1.7.5. Summary

The derivational processes described in this section may be summarised thus:

#### Verb-to-Verb Processes

(DR 1)	V state  root	->	V process  root + { fierientiser vertitiviser
(DR 2)	V state  root	->	V action  root + activativiser
(DR 3)	V process  root	->	V state  root + { resultativiser aptativiser positionaliser
(DR 4)	V process  root	->	V process action  root + causativiser
(DR 5)	V action  root	->	V state  root + { inclinativiser <sub>1, 2</sub> abilitativiser <sub>1, 2</sub> associativiser

(DR 6)	V action	-->	V process action
	root		root + processiviser
(DR 7)	V process action	-->	V process
	root		root + de-causativiser
(DR 8)	V process action	-->	V action
	root		root + de-processiviser
(DR 9)	V process action	-->	V state
	root		root + $\left\{ \begin{array}{l} \text{inclinativiser}_{1, 2} \\ \text{abilitativiser}_1 \end{array} \right\}$

## Verb-to-Noun Processes

(DR 10)	V state	-->	N abstract
	root		root + $\left\{ \begin{array}{l} \text{nominaliser}_1 \\ \text{abstractiviser}_1 \end{array} \right\}$
(DR 11)	V state	-->	N -abstract
	root		root + singulary counter
(DR 12)	V process	-->	N abstract
	root		root + $\left\{ \begin{array}{l} \text{nominaliser}_2 \\ \text{abstractiviser}_2 \end{array} \right\}$
(DR 13)	V action	-->	V abstract
	root		root + $\left\{ \begin{array}{l} \text{nominaliser}_3 \\ \text{complementiser} \\ \text{modaliser} \end{array} \right\}$
(DR 14)	V process action	-->	N abstract
	root		root + nominaliser <sub>4</sub>

The various possibilities for derivation are manifested more graphically by the following diagram (Figure 1):

DERIVED N

V

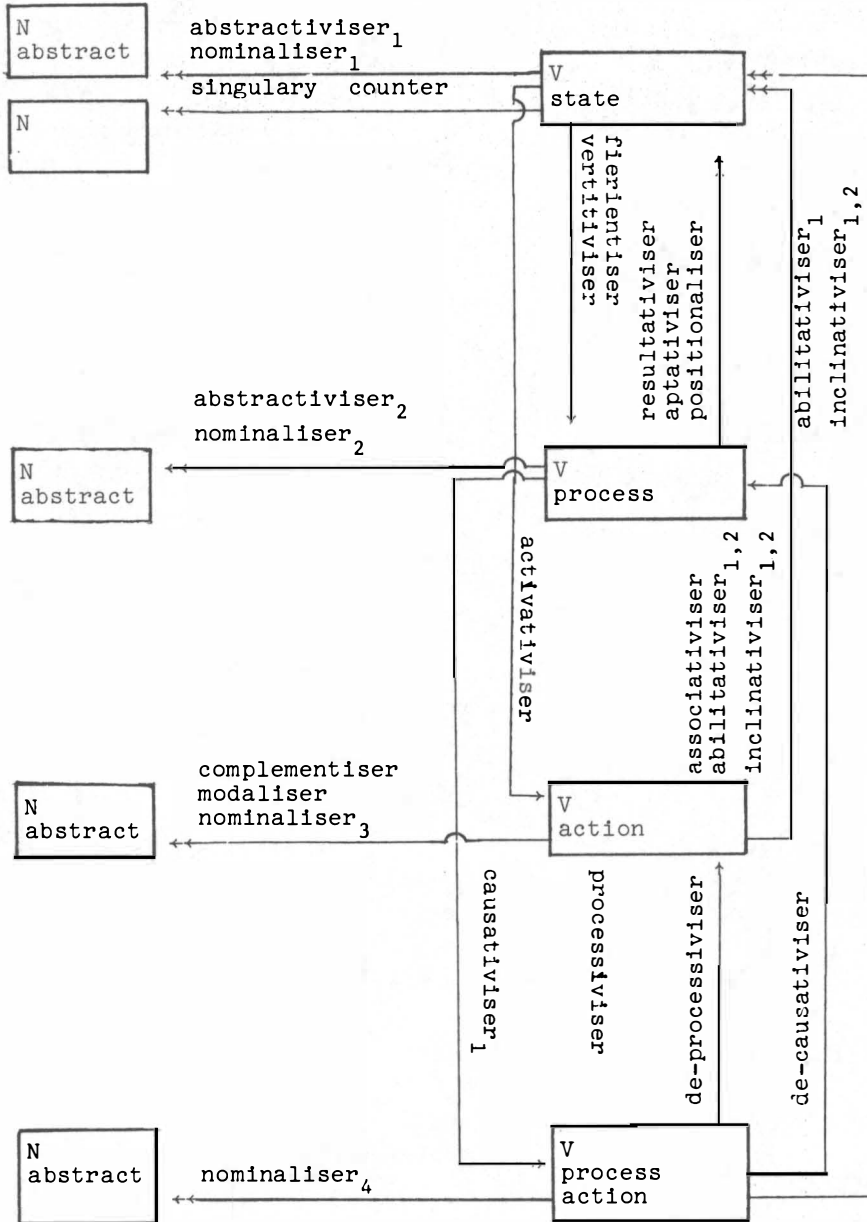

FIGURE 1

Figure 1 gives an idealised partial picture of a lexical item which has maximal derivational possibilities; the picture is partial since Noun-to-Verb derivations will not be treated until section 1.2.2. Within the domain of verb roots, any root (basic or derived) may travel across a derivational path, provided the path is not blocked by the lack of connecting lines (which break the circuit, as it were) or by double-deaded arrows which indicate the end of a verb-to-verb path. The constraints on derivational possibilities are not clear at present and must be studied separately. In the data gathered, no examples were found of direct paths from state to process-action V's (although there were numerous examples of paths from process-action to state V's); moreover, there were no direct paths from action to process V's, nor from process to action V's.

The derivational possibilities of lexical units are highly idiosyncratic in any language. The lexicon would have to note such peculiarities of derivation, and symbolisation rules would have to state irregular symbolisations of derivational units. For example, it has already been stated that *lákad* 'to walk' may occur with either *abilitativiser*<sub>1</sub> (*maka-*) or with *abilitativiser*<sub>2</sub> (*mi-*), whereas *pútut* 'to cut' may occur only with *abilitativiser*<sub>1</sub>. To take only one example of derivational possibilities, one may consider the inherent state V *báyu* 'new':

DERIVED N

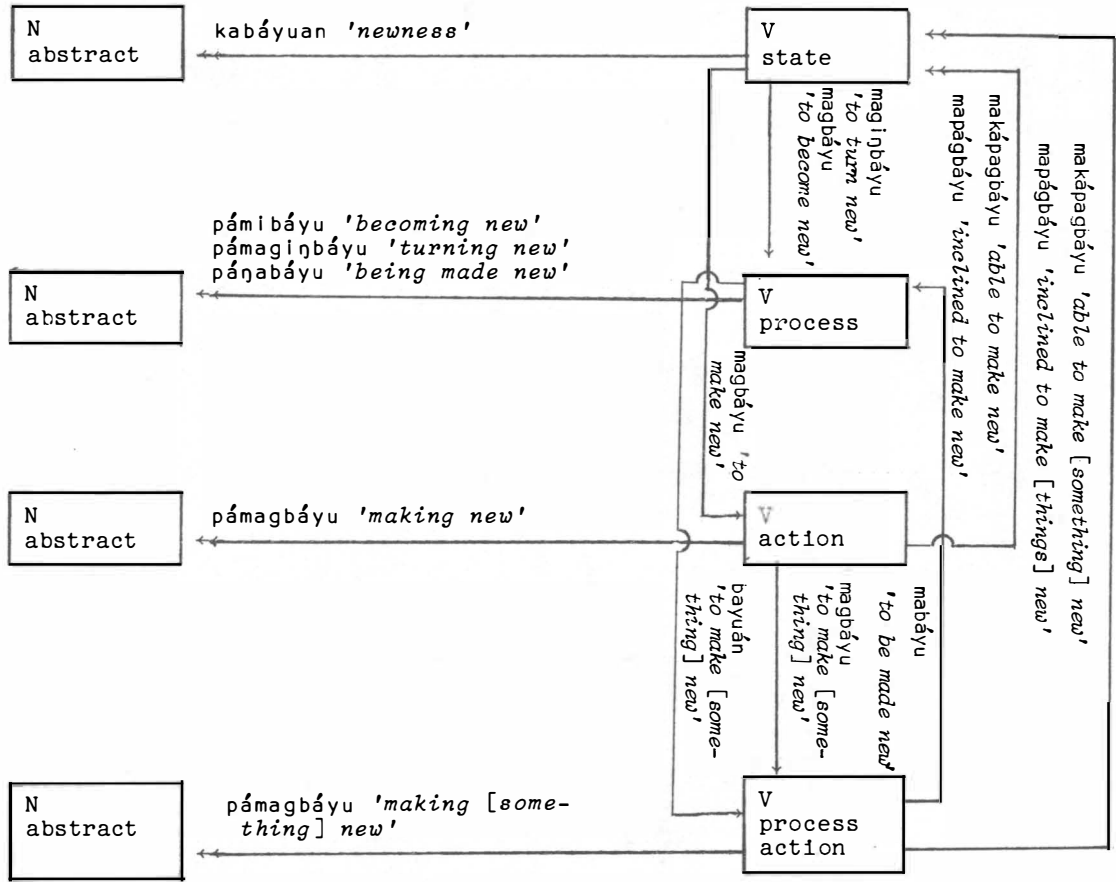

FIGURE 2

When one considers that one can take a derived V such as *magbáyu* 'to make [something] new' and add to it derivational units of the first type (units which add meaning but do not affect categorisation or sub-categorisation), then the agglutinative possibilities of the verb root in Pampangan become formidable indeed. This aptness for agglutination, symbolised usually by CV and CVCV particles, constitutes one of the distinctive features of Pampangan and would figure prominently in typologising it. In actual usage, the number of semantic derivational units attached to the root is usually only one or two, three at the most. Still, these monstrous accretions are possible:

<i>magbáyu</i>	<i>new + activativiser + processiviser</i> 'to make [something] new'
( <i>mag</i> ) <i>pabáyu</i>	<i>new + activativiser + processiviser + causativiser<sub>2</sub></i> 'to cause [somebody] to make [something] new'
<i>pakápabáyu</i>	<i>new + activativiser + processiviser +</i> <i>causativiser<sub>2</sub> + exertiviser</i> 'to exert [oneself] in causing somebody to make [something] new'
<i>makipagpakápabáyu</i>	<i>new + activativiser + processiviser +</i> <i>causativiser<sub>2</sub> + exertiviser + participativiser</i> 'to participate [with some group] in exerting [oneself] in causing [somebody] to make [something] new'
<i>*maká+makipag+paká+pa+báyu &gt; makápakipagpakápabáyu (*m &gt; p)</i>	
	<i>new + activativiser + processiviser + causativiser<sub>2</sub> + exertiviser +</i> <i>participativiser + abilitativiser<sub>1</sub></i> 'to be able to participate [with some group] in exerting [oneself] in causing [somebody] to make [something] new'

In turn, the penultimate example, *makipagpakápabáyu* may be converted into a nominal, *pámakipagpakápabáyu* 'the action of participating [with some group] in exerting [oneself] in causing [somebody] to make [something] new': *new + activativiser + processiviser + causativiser<sub>2</sub> + exertiviser + participativiser + nominaliser<sub>4</sub>*.

#### 1.1.8. Verb Inflectional Units

To summarise thus far, in generating the semantic structure of a sentence, V must be specified for selectional units (state, process, action, process-action; further specifications within each very sub-type), which in turn narrow down to a lexical unit (either an inherent verb root or a derived noun-to-verb or verb-to-verb root, previously generated by derivational processes and stored in the lexicon). Once the lexical unit has been selected, V must be specified still further

by inflectional units, semantic units which specify any lexical verb root and therefore do not function to narrow down verb selection but pre-suppose it.

In Pampangan, these inflectional units involve such units as 'equatative', 'comparative', and 'superlative' as well as 'intensive' and 'minutive' for state V's; units such as 'perseverative', 'repetitive', 'intermittent', and aspectual specifications for non-state V's. Both state and non-state V's may likewise be inflectionally specified as generic.

#### 1.1.8.1. State Verb Inflections

Consider the sentences:

(1.1.8.1.1) masantíŋ ya # íŋ anák  
'The child is pretty.'

(1.1.8.1.2) makaluklúk ya # íŋ anák  
'The child is in a sitting position.'

In the first sentence, \*ma+santíŋ 'pretty' (lit. *comeliness* + plenitiver) is a permanent quality, whereas in the second sentence, \*maka+luklúk 'in a sitting position' (lit. *sit* + positionaliser) is an impermanent state. For the permanent quality, the inflectional unit 'generic' will be used in the sense of a permanent or habitual disposition or state. Many non-generic state V's are formed with the derivational unit positionaliser.

It is only generic state V's which may be inflectionally specified as equatative, comparative, or superlative:

(1.1.8.1.3) (mas) masantíŋ ya # kaŋ Pédro # íŋ anák  
'The child is better-looking than Pedro.'

(1.1.8.1.4)\* kasíŋ santíŋ na ya naŋ Pédro # íŋ anák >  
kasíŋ santíŋ neŋ Pédro # íŋ anák  
'The child is as good-looking as Pedro.'

(1.1.8.1.5) pékamasantíŋ yaŋ díli # kaŋ gaŋ ának # i Pédro  
'Pedro is the best-looking of all among all the children.'

It should be noted that a non-generic state V such as makaluklúk 'in a sitting position' cannot be inflectionally specified by the units 'equatative', 'comparative', or 'superlative'.

If a generic state V is not specified as either equatative, comparative, or superlative, it may be specified as intensive or minutive:

(1.1.8.1.6) masantíŋ yaŋ masantíŋ # iŋ anák  
 'The child is pretty-pretty.' =  
 'The child is very pretty.'

(1.1.8.1.7) masantíŋsantíŋ ya # iŋ anák  
 'The child is somewhat pretty.'

where the two types of re-duplication symbolise the units 'intensive' and 'minutive' respectively. (In Chapter III, an alternative analysis for 'intensive' and 'minutive' will be proposed; the possibility that these units are separate state V's in their own right, adverbs in other words, should at least be considered. However, for the moment, these units will be considered as inflectional units.)

Abilitative state V's, for example, mákalákad 'able to walk' (note that abilitativiser<sub>1</sub> máka- should not be confused with positionaliser maka-), it has been mentioned, may likewise be specified aspectually. Aspectual specification will be discussed in connection with non-state V's.

The inflectional specifications of state V's may be summarised by the following rules (Semantic Verb Inflectional Rules, hereinafter SVIR):

- (SVIR 1) V  
 state  
 root - → generic
- (SVIR 2) V  
 state - → { equative  
 comparative  
 superlative }  
 root  
 generic { (intensive  
 minutive ) }

#### 1.1.8.2. Non-State Verb Inflections: Perseverative, Repetitive, Intermittent.

Consider the sentences:

(1.1.8.2.1)\* mitta+talúsad na ya+ŋ mitta+talúsad # iŋ anák >  
 mitatalúras neŋ mitalalúras # iŋ anák  
 'The child keeps on slipping.'

(1.1.8.2.2)\* lá+lákad na ya+ŋ lá+lákad # iŋ anák >  
 lálákad neŋ lálákad # iŋ anák  
 'The child keeps on walking.'

(1.1.8.2.3)\* pú+pútut na ya+ŋ pú+pútut dútuŋ # iŋ anák >  
 púpútut neŋ púpútut dútuŋ # iŋ anák  
 'The child keeps on cutting wood.'

The re-duplication of the non-state V roots symbolises a semantic unit 'perseverative'. (Again, in Chapter III, the possibility that such a unit is an adverb, a separate state V, must not be gainsaid. However, for the moment, 'perseverative' will be considered an inflectional unit specifiable of non-state V's).

A non-state V may likewise be specified as 'repetitive' in the sense of an event occurring many times, hence, plurality of occurrence. This repetition may be specified further as 'intermittent' if the event is repeated only occasionally:

- (1.1.8.2.4)\* má+ηa+talúsad ya # iη anák >  
 máηatalúras ya # iη anák  
 'The child is slipping repeatedly.'
- \* má+ηa+talú+talúsad ya # iη anák >  
 máηatalútalúras ya # iη anák  
 'The child is slipping intermittently.'
- (1.1.8.2.5) máηlákad ya # i Pédru  
 'Pedro is walking repeatedly.'
- máηlakálákad ya # i Pédru  
 'Pedro is walking intermittently.'
- máηpútut yaη dútuη # i Pédru ~  
 mámuútut yaη dútuη # i Pédru  
 'Pedro is cutting wood repeatedly.'
- máηputúpútut yaη dútuη # i Pédru  
 'Pedro is cutting wood intermittently.'

In the above sentences, the unit 'repetitive' is symbolised by infix -ηa- in 1.1.8.2.4 and by a prefix maη- in 1.1.8.2.5 and 1.1.8.2.6; the unit 'intermittent' is symbolised by CVCV re-duplication.

It is likewise possible to have the following contrasts:

- (1.1.8.2.7) masantíη ya # iη anák  
 'The child is pretty.'
- \* ma+ηa+santíη la # diη ának >  
 maηasantíη la # diη ának  
 'The children are pretty.'
- (1.1.8.2.8) mamamaté ya # iη manúk  
 'The chicken is dying.'
- \* má+ηa+matáy la # diη manúk >  
 máηamaté la # diη manúk  
 'The chickens are dying.'



where the abilitative state V *mákalákad* 'able to walk' (lit. *walk* + abilitativiser<sub>1</sub>) must be inflectionally specified as generic, in the sense of a permanent or habitual disposition. Now, this generic ability may be either actual or non-actual. If non-actual, one says:

- (1.1.8.3.2) *makáíákad ya # i Pédru*  
'Pedro will be able to walk.'

If actual, it may be further specified as completed:

- (1.1.8.3.3) *mékalákad ya # i Pédru*  
'Pedro was able to walk.'

Non-state V's may likewise be specified as generic in the sense of 'having a timeless propensity to do such and such a thing or to undergo such and such a process' (see Chafe 1970b:271). The notion 'generic' may be exemplified better by using a frequentative time N with V:

- (1.1.8.3.4) *íáíákad ya # i Pédru # aídóídí*  
'Pedro walks every day.'

(\**aídó+aídó* < \**aídáw+aídáw* 'daily' (lit. *sun* + *sun*)). Instead of generic, a non-state V may be specified as actual, in which case it must be further specified as either completed or durative. An example of -actual specification is:

- (1.1.8.3.5) *lumákad ya # i Pédru*  
'Pedro will walk.'

It should be noted that -actual specification is likewise used for commands, since commands are intrinsically -actual:

- (1.1.8.3.6) *lumákad ka*  
'Walk!'

It is likewise possible for a -actual and -state V to be generic:

- (1.1.8.3.7) *lumákad ka aídóídí*  
'Walk every day!'

If V is actual completed, one says:

- (1.1.8.3.8) *ífnákad ya # i Pédru*  
'Pedro walked.'

If V is actual durative, one says:

- (1.1.8.3.9) *íáíákad ya # i Pédru*  
'Pedro is walking [right now].'

It should be noted that the symbolisation of actual durative aspect is homophonous with the symbolisation of generic (see 1.1.8.3.4). Moreover, if a non-state V is specified as actual and completed, it may be further specified as immediate:

- (1.1.8.3.10) kalákadiákad na pá muᅇ Pédru  
*'Pedro has just now walked.'*

where the specification immediate occurs only when V has no other specifications occurring with it which are eventually symbolised by affixes; no other affix, in other words, may occur with ka- and re-duplication. V's specified as immediate are likewise peculiar insofar as no subject occurs in such sentences and the particles \*pá? mu? 'just now' must accompany V.

In Pampangan, aspectual specification is separate from temporal specification. It is thus possible to say:

- (1.1.8.3.11) púpútut yaᅇ dútuᅇ # i Pédru  
 and mean both

*'Pedro is cutting wood.'*  
*'Pedro was cutting wood.'*

Tense or time specification is dis-ambiguated by a contextual time adverb which may be explicitly coded:

- (1.1.8.3.11a) púpútut yaᅇ dútuᅇ # i Pédru # nápun  
*'Pedro was cutting wood yesterday.'*  
 (1.1.8.3.11b) púpútut yaᅇ dútuᅇ # i Pédru # ᅇní  
*'Pedro is cutting wood now (or today).'*

Sentences such as the ones above will be discussed in Chapter III at greater length.

Although there is an intrinsic semantic connection between event and time, what seems to be cognitively salient for Pampangan V's are such semantic dimensions as generic and non-generic, actual and non-actual (potential), durative and non-durative (continuative and non-continuative), completed and non-completed, and if completed, immediate or non-immediate. (The dimensions actual/potential and durative/non-durative are from Bloomfield 1917.)

The generalisations on inflectional aspect for abilitative state V's and for non-state V's may be formulated thus:

- (SVIR 5) V  
 state  
 abilitative → generic  
 root + abilitatiser

- (SVIR 6) V  
 state  
 abilitative  
 root + abilitatiser  
 generic - → actual



V -state (action) root generic	lálákad ya # iŋ anák  'The child walks [habitually].'
V action root -actual	lumákad ya # iŋ anák 'The child will walk.'  lumákad ka 'Walk!'
V action root -actual generic	lumákad ka # aldóldó  'Walk every day!'
V action root actual durative	lálákad ya # iŋ anák  'The child is walking [right now].'
V action root actual completed	línákad ya # iŋ anák  'The child walked.'
V action root actual completed immediate	kalákadiákad na pa mu niŋ anák  'The child has just now walked.'

#### 1.1.8.4. Verb Inflectional Units: Negative

Consider the sentences.

- (1.1.8.4.1) é ya maganaká? # iŋ anák  
'The child is not kind.'
- (1.1.8.4.2) é ya dáragúl # iŋ anák  
'The child is not growing.'
- (1.1.8.4.3) é ya mámanán # iŋ anák  
'The child is not eating.'
- (1.1.8.4.4) é ya púpútut dútuŋ # iŋ anák  
'The child is not cutting wood.'

The unit 'negative' is an inflectional unit insofar as it does not narrow down the choice of a lexical unit for V but may specify any V root. The relevant rule is:

(SVIR 11) V  
 root → negative

The unit 'negative' is post-semantically linearised by being placed before the verb root and is eventually symbolised by an unbound and accented particle *é*.

It is interesting to note that Pampangan, unlike English and the other Indo-European languages, has for practical purposes no derivational unit *negativiser*, as one finds, for example, in an English noun such as '*dishonour*', an adjective such as '*uncommon*', and a verb such as '*mismanage*'. Negative counterparts of state V's or traditionally adjectives are either inflectionally negated as in

(1.1.8.4.5) *é ya máyap # iŋ anák*  
*'The child is not good.'*

or another root is used, as in

(1.1.8.4.6) *marók ya # iŋ anák*  
*'The child is bad.'*

It is only with a small set of verb roots that the unit *negativiser* occurs as a derivational unit:

(1.1.8.4.7) *atí yu # i Pédru* '*Pedro is present.*'  
*alá yu # i Pédru* '*Pedro is absent.*'

(1.1.8.4.8) *atín ya # i Pédru* '*Pedro has [something].*'  
*alá ya # i Pédru* '*Pedro has nothing [of something].*'

(1.1.8.4.9) *iyá pin # iyán* '*That is he, indeed.*'  
*alíwa pin # iyán* '*That is not he, indeed.*'

where the second V in the three pairs is *present + negativiser*, *have + negativiser*, and *predicate noun + negativiser*, respectively. Considering the myriad agglutinative possibilities of derivation in Pampangan, the restraint in the language with regard to the derivational unit *negativiser* is surprising and perhaps typologically significant.

## 1.2. SPECIFYING N

This second part of the chapter describes the selectional units for N's, noun derivational processes, and noun inflectional units.

### 1.2.1. Selectional Units

The selectional units of N serve to narrow down through successive specifications the lexical units of the N's accompanying V. For the most part, these selectional units are available to all languages

(doubtless a result of the basic sameness of human nature and of human experience); specifications become more detailed as lexical units peculiar to a culture are described.

A distinction must first be made between abstract and non-abstract (or concrete) nouns in Pampangan:

(1.2.1.1) masantíŋ ya # iŋ báru mu  
'Your dress is pretty.'

(1.2.1.2) máyap # iŋ bálak mu  
'Your opinion is sound.'

(\*ma+santíŋ 'pretty' (lit. *comeliness* + plenitiviser, báru? 'dress', mu 'your', \*ma+káyap 'sound' (lit. *goodness* + plenitiviser), bálak 'opinion'). In the first sentence, báru? is non-abstract and certain of its specifications are incorporated into V and eventually symbolised as ya 'it'; in the second sentence, however, bálak is abstract and none of its specifications are incorporated into V. The relevance of the semantic distinction is thus attested by the presence or absence of the output of a post-semantic process to be described in Chapter II as one of incorporation.

It will be shown in Chapter II that nominals (verb root + nominaliser) as well as the outputs of nominalisation processes are considered as abstract; hence, incorporation processes do not apply to such.

bálak is an inherently abstract noun root. In addition to inherently abstract noun roots, there are many derived abstract noun roots in Pampangan, the outputs of a very productive derivational process; for example, táu 'man' > \*ka+táutan 'man-ness = human-ness'.

N may likewise be specified as count. Thus, one may say:

(1.2.1.3) mámaŋán yan aduáŋ ébun # | Pédrú  
'Pedro is eating two eggs.'

but not

(1.2.1.4)<sup>x</sup> mámaŋán yan aduáŋ nási? # | Pédrú  
<sup>x</sup> 'Pedro is eating two rices.'

(maŋán 'to eat', aduá? 'two', ébun 'egg', nási? 'rice'). ébun is a count N and may be accompanied by a quantitative numerical specification aduá? but not nási? which although non-abstract is non-count. Non-count N's (like abstract N's) do not undergo incorporation into the verb phrase:

(1.2.1.5) maputí ya # iŋ ebún  
'The egg is white.'

(1.2.1.6) maputí? # iṅ nási?  
'The rice is white.'

(\*ma+putí? 'white' (lit. *quality of being white* + plenitiver)).

Non-abstract (count or non-count) N's may likewise be further specified as potent, that is, as having some intrinsic motile power, as in:

(1.2.1.7)\* biklát na ya niṅ áṅin # iṅ pasbúl >  
biklát ne niṅ áṅin # iṅ pasbúl  
'The door was opened by the wind.'

(biklát 'opened' from buklát 'to open', áṅin 'wind', pasbúl 'door'), where áṅin is analysable as an agent which is redundantly potent, as was discussed in section 1.1.5. One can likewise say:

(1.2.1.8)\* s+in+ífra? na ya niṅ impún # iṅ baldósa  
sínfra ne niṅ impún # iṅ baldósa  
'The concrete floor was cracked by the tree (for example,  
if its roots crack the floor from beneath).'

(sífra? 'to break', impún 'tree', baldósa 'tile floor' from Spanish baldosa 'paving') where the tree, a count N, is a potent agent of destruction.

N's which are count and potent may be further specified as animate, as in:

(1.2.1.9) matápaṅ ya # iṅ ásu  
'The dog is ferocious.'

(\*ma+ttápaṅ 'ferocious' (lit. *quality of being aggressive* + plenitiver)), where ásu is count, potent, and animate. Non-animate N's may be further specified as body of water, place, object, and the like (these will undoubtedly constitute a large set of classificatory nouns or superordinates). The following examples may be cited:

(1.2.1.10) malápad ya # iṅ ílug  
'The river is wide.'

(\*ma+lápad 'wide' (lit. *width* + plenitiver)), where ílug is count, -animate, and body of water (and perhaps, in certain contexts, potent).

(1.2.1.11) maragúl ya # iṅ báryu  
'The village is big.'

(\*ma+dagúl 'big' (lit. *size* + plenitiver), báryu 'village' from Spanish barrio), where báryu is count, -animate, and place.

(1.2.1.12) mátas ya # iṅ gusáli?  
'The building is tall.'

(\*ma+ta?ás 'tall' (lit. *height* + plenitiviser), gusáli? 'building'), where gusáli? is count, -animate, and object.

N's specified as animate may be further specified as human and/or feminine:

(1.2.1.13) sásabsáb ya # in ásu  
'The dog is devouring [food].'

(sabsáb 'to devour' (cf. German *fressen*), ásu 'dog'), where the verb root is specifically reserved for non-human animate agents; of course, if one intends to be pejorative, the verb root sabsáb may be predicated of human N's. Both human and non-human N's may occur with \*mañ+kán, a different root.

It has sometimes been claimed that Pampangan and the other Philippine languages in general do not mark for masculine and feminine gender. This observation is inaccurate. It is true that the distinction masculine/feminine is not marked in pronouns. However, the occurrence of such noun pairs as

lalaki	'man'	babáyi	'woman'
táta	'father'	indá? ~ indu?	'mother'
káka	'older brother'	átí	'older sister'
bápa	'uncle'	dára	'aunt'
tátiyo < *tátiyaw	'rooster'	gaindú?	'hen'
bulúgan	'male pig'	gaindú?	'sow'

clearly shows that the semantic unit 'feminine' is necessary for characterising N's. The masculine/feminine distinction is universal, although manifested in different ways in different languages. In Pampangan (and the other Philippine languages), it is less overtly marked. Even in selectional restrictions between V and N, however, the semantic unit 'feminine' must be considered. One can say:

(1.2.1.14) malagú ya # in babáyi  
'The woman is beautiful.'

(\*ma+lagú? 'beautiful' (lit. *beauty* + plenitiviser), babáyi 'woman'), but one would not predicate malagú? of a man, unless one intends to imply that the man is effeminate. Instead, one would use either sexually neutral masantíñ 'good-looking' or sexually non-neutral (-feminine) guápu, from Spanish *guapo*. Other state V roots which demand a feminine-specified patient N are malandí 'wanton' and malastúd 'flirtatious'.

Human N's may be further specified as 'first person' (referring to the speaker) and/or 'second person' (referring to the hearer). The

selection of first and/or second person precludes lexical specification of N; instead, the N specifications, together with inflectional specifications, are directly symbolised by traditional pronouns (pronouns will be discussed in detail in Chapter III):

- (1.2.1.15) *lálákad ku*            *'I am walking.'*  
 (1.2.1.16) *lálákad ka*            *'You are walking.'*  
 (1.2.1.17) *lálákad katá*        *'You and I are walking.'*

Moreover, non-abstract count N's, animate or non-animate (if animate, neither first nor second person), may be further specified as collective or unique. Collective specification must be distinguished from inflectional plural; there are noun roots which inherently refer to a collection of persons, places, objects, and the like, which in turn may be specified inflectionally as plural. Unique N's are traditional proper nouns. Thus:

- (1.2.1.18) *atí yu # kíŋ balé # íŋ púlun*  
*'The council is in the house.'*

where *púlun* 'council' is a collective human N.

- (1.2.1.19) *dakál ya kalakutí? # í Pédru*  
*'Pedro has lots of odds-and-ends.'*

(*dakál* 'lots of', *kalakutí?* 'odds and ends'), where *kalakutí?* is a collective object N.

- (1.2.1.20) *atí yu # í Pédru*  
*'Pedro is present.'*

where *Pédru* is a unique human N.

In addition, a human N may be specified as abstract. Non-abstract N's may be count and/or potent. Count potent N's may be further specified as animate. Non-animate count N's may be further specified as body of water, place, object, and the like, while animate N's may be further specified as human and/or feminine. Human N's may be further specified as first and/or second person. Non-abstract count N's (if they are not specified as first and/or second person) may be further specified as collective or unique. These generalisations may be formulated through the following rules:

- (S1.2.1)        N                    - →        abstract  
 (S1.2.2)        N                    - →        (count)  
                   -abstract        - →        (potent)

(S1.2.3)	N count potent	- →→	animate
(S1.2.4)	N count -animate	- →→	{ body of water place object ... }
(1.2.5)	N animate	- →→	(human feminine)
(S1.2.6)	N human	- →→	(first person second person)
(S1.2.7)	N count -first person -second person	- →→	{ collective unique }

## Sample Lexical Rules

(LR1.2.1)	N abstract	→→	<i>thought, opinion, man</i> + abstract- iviser, VERB ROOT + nominaliser,...
(LR1.2.2)	N count	→→	<i>river, lake, stream, sea,...</i>
(LR1.2.3)	N count place	→→	<i>country, city, municipality,...</i>
(LR1.2.4)	N count object	→→	<i>stone, egg, chair, table,...</i>
(LR1.2.5)	N potent	→→	<i>wind(air), water, fire,...</i>
(LR1.2.6)	N count potent	→→	<i>tree, car, truck,...</i>
(LR1.2.7)	N -count -potent	→→	<i>rice, corn, sugar,...</i>
(LR1.2.8)	N count potent animate	→→	<i>dog, cat, horse,...</i>
(LR1.2.9)	N count potent animate human	→→	<i>man, uncle, older brother,...</i>

- (LR1.2.10) N  
count  
potent  
animate  
feminine → *hen, sow,...*
- (LR1.2.11) N  
count  
potent  
animate  
human  
feminine → *woman, aunt, older sister,...*
- (LR1.2.12) N  
count  
object  
collective → *odds-and-ends, equipment,  
furniture,...*
- (Lexical units for 'equipment' and 'furniture' in Pampangan, *kasankápan* and *muéblis* from Spanish *muebles*, are count nouns.)
- (LR1.2.13) N  
count  
object  
unique → *Rizal Monument, Spoliarum (a famous painting by a local artist),...*
- (LR1.2.14) N  
count  
place  
collective → *archipelago, mountain range, house + locativiser (a place where houses are clustered together = village),...*
- (LR1.2.15) N  
count  
place  
unique → *Manila, Pasay City,  
The Philippines,...*
- (LR1.2.16) N  
count  
body of water  
collective → (no examples found in the data)
- (LR1.2.17) N  
count  
body of water  
unique → *Pasig River, Lake Taal,  
Pampanga River,...*
- (LR1.2.18) N  
count  
animate  
collective → *herd,...*
- (LR1.2.19) N  
count  
animate  
unique → *Bantay (a dog's name), Kastanyu  
(a horse's name),...*
- (LR1.2.20) N  
count  
animate  
feminine  
collective → (no examples were found in the data)

- (LR1.2.21) N  
count  
animate → Kuning (*a female cat's name*),  
feminine → Chiquita (*a female dog's name*),...  
unique
- (LR1.2.22) N  
count  
animate →  
human → *committee, council, family,...*  
collective
- (LR1.2.23) N  
count  
animate →  
human → Juan, Pedro, Mario,  
unique → Bayani, Lapu-Lapu,...
- (LR1.2.24) N  
count  
animate →  
human → (examples were loanwords from  
feminine → English and Spanish: *Catholic*  
collective → *Women's League, YWCA,...*)
- (LR1.2.25) N  
count  
animate →  
human → Maria, Ana, Pilar,  
feminine → Liwayway, Bulaklak, Luningning  
unique

(In those N matrices where no examples were found in the data, the gap is accidental, since the combinations are well within the system as possible specifications of lexical items. It is probably in these areas of the lexicon where gaps exist that borrowing is most frequent.)

The influence of Christianity and of Spanish culture has done away with the native names completely in most of the Philippine languages, except in the languages of non-Christian minorities. Names for women such as Liwayway lit. '*Dawn*', Luningning lit. '*Light*', Bulaklak lit. '*Flower*' and for men such as Lapu-Lapu lit. '*Grupa Fish (perhaps with totemic overtones)*', Bayani lit. '*Hero*' are best considered as mono-lexemic idioms which in the process of semantic generation would have to be literalised (see Chafe 1970b:63-5). Sentential names such as '*He Who Laughs*', quite common in Amerindian languages, are not found in Pampangan. Such descriptive appellations may be used ad hoc to refer to somebody; in such cases, the sentence contains a relative clause:

- (1.2.1.22) atí yu # in dínatán nápun  
'*He who came yesterday is present.*'

### 1.2.2. Noun Derivational Processes

Besides verb derivational processes (verb-to-verb; verb-to-noun) discussed in section 1.1.7, there are likewise noun derivational processes (noun-to-noun; noun-to-verb) by which inherent non-state and non-event roots become other sub-types of non-state and non-event roots or become derived state and event roots. Once a noun root has been derived into a verb root, it may undergo the same derivational processes that a verb root may undergo (see section 1.1.7). In this section, for purposes merely of illustration of various possibilities, only one noun root, *aná́k* 'child', will be used, and its derivational possibilities presented as a paradigm.

#### 1.2.2.1. Noun-to-Noun Derivational Processes

As with verb roots, derivational processes not only add meaning but also, at times, change the sub-categorisation of N. From the basic root *aná́k*, the following nouns may be derived:

<i>pékaaná́k</i>	<i>child</i> + substitutiviser 'one who substitutes as a child to someone, for example, a foster-child'
<i>télaaná́k</i>	<i>child</i> + imitativiser 'a child-like object, for example, a cookie shaped like a child'
<i>aná́kaná́kan</i>	<i>child</i> + fictiviser 'a make-believe child'
<i>miánák</i>	<i>child</i> + dual counter 'a group of two children'

*aná́kaná́kan* is used in child's play; otherwise, in ordinary contexts, it would be pejorative. *mi-* is highly productive and occurs most often with kinship terms: *mitá́ta* 'father and child' (lit. *father* + dual counter), *miíndá?* 'mother and child' (lit. *mother* + dual counter). Initially, it might be characterised as a marker of mutuality. However, its occurrence with a kinship-neutral term such as *aná́k* makes it more plausible to place it in the subset of counters. (It has been shown that there is a singulary counter symbolised by *ka-*, as in *kapútut* 'a slice'.) Although *mi-* is a dual counter, it requires as a context some relation of mutuality.

Bergaño likewise lists *kayanakán*, which has several meanings. It may mean 'the state of being young', in other words, a nominal. Bergaño glosses it as 'niñez' or 'childhood', in the frame of reference adopted in this study, *child* + temporal measure marker. In my dialect, it can also mean 'the set of children', hence, *child* + universal collectiviser.

It should be noted that in the first, third, and fourth examples, N does not change its sub-categorisation; in the second example, however, N becomes -animate and -human, an object. In the fifth example, when *kayanakán* means '*childhood*', N is abstract; when it means '*the set of children*', N is collective.

The relevant rules may be formulated thus:

(DR 15)	N	- →	N
	root		root + { (substitutiviser) fictiviser dual counter }
(DR 16)	N	- →	N object
	root		root + imitativiser
(DR 17)	N	- →	N abstract
	root		root + temporal measure marker
(DR 18)	N	- →	N collective
	root		root + universal collectiviser

As DR 15 has been formulated, it is possible to generate a noun such as *pékaanákanakan* '*that which substitutes as a make-believe child*' (lit. *child* + *fictiviser* + *substitutiviser*), admittedly an unusual combination. It is conceivable, however, in child's play, for an object of some kind to substitute as a doll or make-believe child. It seems, however, that DR 15-18 are disjunctively ordered with regard to each other, since other combinations were tried and were found to be unacceptable.

#### 1.2.2.2. Noun-to-Verb Derivational Processes

##### 1.2.2.2.1. Noun to State Verbs

Consider the sentence:

(1.2.2.2.1.1) *aná k ya # i Pédru*

The sentence is ambiguous. It has two possible meanings:

*'Pedro is a child.'*

*'Pedro is young.'*

It is not perfectly clear whether *aná k* is a homonym for two separate roots, '*child*' and '*young*'. Tentatively, both the predicate noun and the state V (a traditional adjective) will be analysed as derived from an inherent noun root, *aná k* '*child*'. For the first meaning, the following rule will be necessary:

(DR 20')	N	→	V
	-abstract		state
	root		root + descriptiviser

where *descriptiviser* is paraphrasable as 'having some salient characteristic of N', in this case, '*child*', the characteristic being '*youth*'. In a more detailed description, there will have to be listed many types of descriptivisers.

In turn, *aná* '*young*' is derivable into an abstract N, a nominal, by DR 10 (see page 67): *aná* '*young*' → *kayanakán* '*the state of being young*' (lit. *child* + descriptiviser + nominaliser<sub>1</sub>), homophonous with but distinct from *kayanakán* '*childhood*' and *kayanakán* '*the set of children*'.

Again, one may have the sentence:

(1.2.2.2.1.2) *makianák ya # i Pédro*  
'*Pedro has a child/children.*'

where the state V is analysable as *child* + habitiviser. The above sentence is distinct from although comparable to

(1.2.2.2.1.3) *atín yaḡ anák # i Pédro*  
'*Pedro has a child/children.*'

*atín* is an inherent state V accompanied by a patient N *aná* and a beneficiary N *Pédro*, whereas *makianák* is a derived state V accompanied by a beneficiary N *Pédro*, with the semantic patient incorporated into the derived state V. Note that the copier *ya* '*he*', which is incorporated into V and follows the verb root, is placed after *makianák* and not after *maki-*. The derivational rule necessary may be formulated thus:

(DR 21')	N	- →	V
			state
			habitive
	root		root + habitiviser

A similar derivational process is operative in

(1.2.2.2.1.4) *mayaná* *ya # i Pédro*  
'*Pedro has many children.*'

where the state V is analysable as *child* + plenitiviser. The unit *plenitiviser*, symbolised by *ma-*, is quite productive, as many examples in preceding sections have shown. DR 21' must therefore be added to:

(DR 21a')	N	- →	V
			state
			habitive
	root		root + plenitiviser

## 1.2.2.2.2. Nouns to Process Verbs

The following sentence is ambiguous:

- (1.2.2.2.1) mágiḡanák ya # i Pédrú  
                   '*Pedro is becoming a child.*'  
                   '*Pedro is becoming young.*'

In the first meaning, the derived process V is analysable as *child* + *fierientiser*; in the second meaning, the derived process V is analysable as *child* + *descriptiviser* + *fierientiser*. The first derived root is the output of a noun-to-process V derivation; the second derived root is the output of a state-to-process V derivation already formulated as DR 1 (see page 66). The rule for the first process may be formulated thus:

(DR 22')	N	-->	V
			process
	root		root + fierientiser

The corresponding nominal of both process V's is pámagiḡanák '*the process of becoming a child/ the process of becoming young*'.

There is another state-to-process verb derivation exemplified by:

- (1.2.2.2.2) méyanák ya # i Pédrú  
                   '*Pedro turned youthful [in appearance].*'

The derived process verb root \*mayanák is defective, however, insofar as it occurs only with actual completed aspect when it is used with the meaning '*to turn youthful [in appearance]*'. The derived process verb root is analysable as *child* + *descriptiviser* + *vertitiviser*, and its corresponding nominal is páḡayanák '*the process of turning youthful [in appearance]*'.

Homophonous with \*matanák '*to turn youthful [in appearance]*' is \*matanák '*to suffer as a result of having many children*':

- (1.2.2.2.3) mayayanák ya # i Pédrú  
                   '*Pedro is suffering from having many children.*'

where the derived process V is analysable as *child* + *plenitiviser* + *patientiser* and is the output of a state-to-process V derivation (DR 1), hence, needing no separate formulation. The corresponding nominal is páḡayanák '*the process of suffering from having many children*' homophonous with the formative meaning '*the process of turning youthful [in appearance]*'.

Likewise directly traceable to a state V makianák '*to have a child/ children*' is the process V magkaanák '*to be in the process of having a child*':

- (1.2.2.2.2.4) mágka(y)aná k ya # i Pédr u  
*'Pedro is in the process of having a child.'* =  
*'Pedro is becoming a father.'*

where the derived process V is analysable as *child* + *habitiviser* + *inchoativiser*. The corresponding nominal for the process V is pámagka(y)aná k *'the process of becoming a father'*.

Consider now the sentence:

- (1.2.2.2.2.5) mipapaḡaná k ya # iḡ bíḡut  
*'The infant is being born.'*

where the derived process V is *child* + *processiviser*. The rule is statable as:

(DR 23')	N	->	V
			process
	root		root + processiviser

The corresponding nominal is pá mipapaḡaná k *'the process of being born'*, although the more common formative is paḡabaft, from another root, mibaft *'to be born'*.

It is possible for mipapaḡaná k *'to be born'* to be accompanied by a source N:

- (1.2.2.2.2.5a) mipapaḡaná k ya # kaḡ Maryá # iḡ bíḡut  
*'The child is being born of Mary.'*

where Maryá seems to be a source N rather than an agent N. Subsequently, it will be shown that there is a derived process-action V, maḡaná k *'to bear a child'*, where there is a clear agent N accompanying V.

### 1.2.2.2.3. Nouns to Action Verbs

In the sentence:

- (1.2.2.2.3.1) máḡaná k ya # i Maryá  
*'Maria is giving birth [to a child].'*

where the derived V, at least in Pampangan, seems to be an action V; the prefix maḡ- (~ mag-) usually occurs in action V's. The derived action V is analysable as *child* + *action verbaliser*, where the unit *action verbaliser* is an ad hoc label paraphrasable as 'to produce N'. It is possible to specify such an action as completable, in which case it will be accompanied by a complement N:

- (1.2.2.2.3.1a) máḡaná k yaḡ bíḡut # i Maryá  
*'Maria is giving birth to an infant.'*

The derivation may be formulated thus:

(DR 24')	N	- →	V
			action (completable)
	root		root + action verbaliser

The corresponding nominal is *pámaṇanák* 'the act of giving birth'.

From the derived action root *maṇanák* 'to give birth', some state V's may likewise be derived. One may say:

- (1.2.2.2.3.2) *mapáṇanák ya # i Maryá*  
'*Maria is inclined to give birth often.*'

where the derived state V is analysable as *child* + *action verbaliser* + *inclinativiser*<sub>2</sub>. The etymology of *mapáṇanák* is not clear; the following is a tentative re-construction: \**mapáṇ+maṇ+anák* > *mapáṇanák* (hapology?). The corresponding nominal is *kapaṇanákán* 'the state of being inclined to give birth often'. One may likewise say:

- (1.2.2.2.3.3) *pálanákan ya # i Maryá*  
'*Maria is naturally inclined to give birth often.*' =  
'*Maria is fertile.*'

where the derived state V is analysable as *child* + *action verbaliser* + *inclinativiser*<sub>1</sub>. Were the agglutination regular, one would expect: \**paḷa+maṇ+anák+an*; however, *maṇ-* is deleted.

From the derived action root *maṇanák* 'to give birth', one may likewise derive certain nouns.

There is a word *kapáṇanák* 'an associate in childbirth', from \**ka+maṇ+anák* lit. *child* + *action verbaliser* + *associativiser*. For example:

- (1.2.2.2.3.4) *kapáṇanák neṇ Maryá # i Ána*  
'*Ana is [an] associate of Maria in childbirth*  
(e.g. *if Ana gave birth more or less at*  
*the same time.*')

where 'associate in childbirth' is a predicate noun.

Another interesting derivative from *maṇanák* 'to give birth' is the Pampangan word for 'birth tract (uterus and vagina)', *pálanákan* (note the homonymy with *pálanákan* 'naturally inclined to give birth often') which may be analysed as *child* + *action verbaliser* + *perlocativiser*, where *perlocativiser* is paraphrasable as 'place through which'.

Likewise directly derivable from *maṇanák* 'to give birth' is derived noun root *paṇanák* 'first-born child', analysable as *child* + *action verbaliser* + *primogeniture marker*.

Still other noun derivatives from 'to give birth' are *paṇanakán* 'nephew/niece', analysable as *child* + *action verbaliser* + *first descend-*

ing collateraliser, and pipáñanák 'a place where one gives birth = maternity hospital', analysable as *child* + action verbaliser + locativiser.

There is yet another noun-to-action V derivation productive of a subset of semantically related forms. Thus:

- (1.2.2.2.3.5) máganák ya # i Maryá  
'*Maria is dealing in children.*'

The sentence of course makes sense only in a culture which permitted slavery. However, the derivational process itself is quite productive and is used in describing various occupational activities, as in \*mag+asán 'to deal in fish' (lit. *fish* + occupationaliser). (DR 24') must be added to, therefore:

- |          |      |     |                         |
|----------|------|-----|-------------------------|
| (DR 24a) | N    | - + | V                       |
|          |      |     | action                  |
|          | root |     | root + occupationaliser |

where the unit occupationaliser is paraphrasable as 'to engage in buying and selling N'.

Related in phonological shape but semantically problematic is derivative kamagának:

- (1.2.2.2.3.6)\* ka+mag+ának na ya nañ Pédrú # i Suán >  
kamagának nañ Pédrú # i Suán  
'*Juan is [a] relative of Pedro.*'

where the state V is a predicate noun, with the noun analysable as *child* + action verbaliser + associativiser<sub>2</sub>. Although kamagának 'relative' is closer in phonological shape to magánák 'to deal in children', the unit occupationaliser is clearly absent in the former: kamagának is actually closer semantically to kapáñanák 'associate in childbirth'. associativiser<sub>2</sub>, symbolised like associativiser<sub>1</sub>, by ka- is paraphrasable as 'associated in childbirth by kinship ties'.

kamagának 'relative' may itself be derived into an action V:

- (1.2.2.2.3.7) kákamagának ya # i Pédrú  
'*Pedro is engaged in the activity of making relatives (e.g., through intermarriage).*'

where now the derived action V is analysable as *child*+ action verbaliser<sub>1</sub> + associativiser<sub>2</sub> + action verbaliser<sub>2</sub>, where action verbaliser is paraphrasable as 'to make [somebody] one's N'. It would seem that a proper accounting of the derived action root 'to make relatives' demands such a semantic re-construction, at least for etymological purposes. This is not to claim, however, that the postulated concatenation of units must be psychologically present to the language

performer; it seems more plausible to hypothesise that some new semantic unit 'relative' is stored which is later post-semantically literalised, as is the case with idioms.

The corresponding nominal of 'to make relatives' is pámagkamagának 'the action of making relatives'. The relevant derivational rule is:

(DR 24b')	N	- →	V
			action
	root		root + action verbaliser <sub>2</sub>

#### 1.2.2.2.4. Nouns to Process-Action Verbs

In the sentence:

(1.2.2.2.4.1)*	anáktán na ya naḡ Maryá # i Pédrú >
	ánakán neḡ Maryá # i Pédrú
	'Pedro is being made [a] child by Maria
	(e.g., through adoption).'

the derived process-action V is analysable as *child* + *action verbaliser*<sub>2</sub> + *processiviser*. It seems that the action of making somebody one's (adopted) child is comparable to the action of making (somebody) a relative, hence, *action verbaliser*<sub>2</sub>. On the other hand, the presence of a patient N makes the postulation of the unit *processiviser* necessary (a result of an action to process-action V derivation). The corresponding nominal is pámagának 'the act of making someone one's child (for example, through adoption)', homophonous with 'the act of dealing in children'. (The derived process-action V anakán was not accepted by all informants; the preferred root for 'to adopt' is \*ampun+án.)

Sentence (1.2.2.2.4.1) above may be inflected for actual completed aspect:

(1.2.2.2.4.1a)*	inánák na ya naḡ Maryá # i Pédrú >
	inanák neḡ Maryá # i Pédrú
	'Pedro was made a child by Maria (e.g.,
	through adoption).'

From inanák may be derived a noun root, inának (note the accentual shift), meaning 'god-child' and semantically analysable as *child* + *action verbaliser*<sub>2</sub> + *processiviser* + *ritual kinship marker*.

Like kamagának 'relative' inának 'god-child' may be derived into a verb root. There is a derived action V, maginának 'to engage in the activity of acting as god-parent', analysable as *child* + *action verbaliser*<sub>2</sub> + *processiviser* + *ritual kinship marker* + *action verbaliser*<sub>2</sub>, as well as a derived process-action V, inánakán 'to make [somebody] one's god-child', analysable as *child* + *action verbaliser*<sub>2</sub> + *process-*

iviser. The corresponding nominal of both 'to engage in the activity of acting as god-parent' and 'to make [somebody] one's god-child' is pámaginának.

A dialectal variant of (1.2.2.2.4.1a) is:

(1.2.2.2.4.1a') méyanák ya # kaŋ Maryá # i Pédrú  
'Pedro was made [a] child by Maria (for example, through adoption).'

The corresponding nominal of the verb root in the above sentence is páŋayanák, which Bergaño glosses as 'filiación' or 'the process of being made someone's child (for example, through adoption)' and which is homophonous with 'the process of turning youthful [in appearance]'.

So far, no derivational process from noun to process-action V has been postulated, since the examples cited were accounted for by processes already formulated. In the sentence

(1.2.2.2.4.2)\* anáktan na ya naŋ Pédrú # i Maryá >  
anákan neŋ Pédrú # i Maryá  
'Maria will conceive by Pedro.'

the derived V seems to be a process-action V directly derivable from the noun root and analysable as *child* + process-action verbaliser. The latter label is ad hoc and is paraphrasable as 'to cause [somebody] to have N'. The correlative nominal is pámaganákan 'the act of begetting a child'. The derivational process may be formulated thus:

(DR 25')	N	- +	V
			process
			action
	root		root + process-action verbaliser

#### 1.2.2.2.5. Summary

By way of summary, the noun-to-verb derivational process will be re-stated:

(DR 19)	N	- +	V
			state
	root		root + predicativiser
(DR 20)	N	- +	V
			state
	root		root + {
			descriptiviser
			habitiviser
			plenitiviser
			}
(DR 21)	N	- +	V
			process
	root		root + {
			fierientiser
			processiviser
			}

(DR 22)	N	- →	V process directional from
	root		root + processiviser <sub>2</sub>
(DR 23)	N	- →	V action (completable)
	root		root + { action verbaliser <sub>1</sub> action verbaliser <sub>2</sub> occupationaliser <sub>2</sub> }
(DR 24)	N	- →	V process action
	root		root + process-action verbaliser

The following diagram shows the possibilities graphically; it includes only the noun-to-noun and noun-to-verb processes and not the verb-to-verb processes, which have already been discussed in section 1.1.7. To see the full derivational outline, Figure 3 should be consulted in conjunction with Figure 1 (on page 68). Following Figure 3 is a diagram showing the various possibilities derived from *aná*k which have been discussed, including the verb-to-verb and verb-to-noun examples cited.

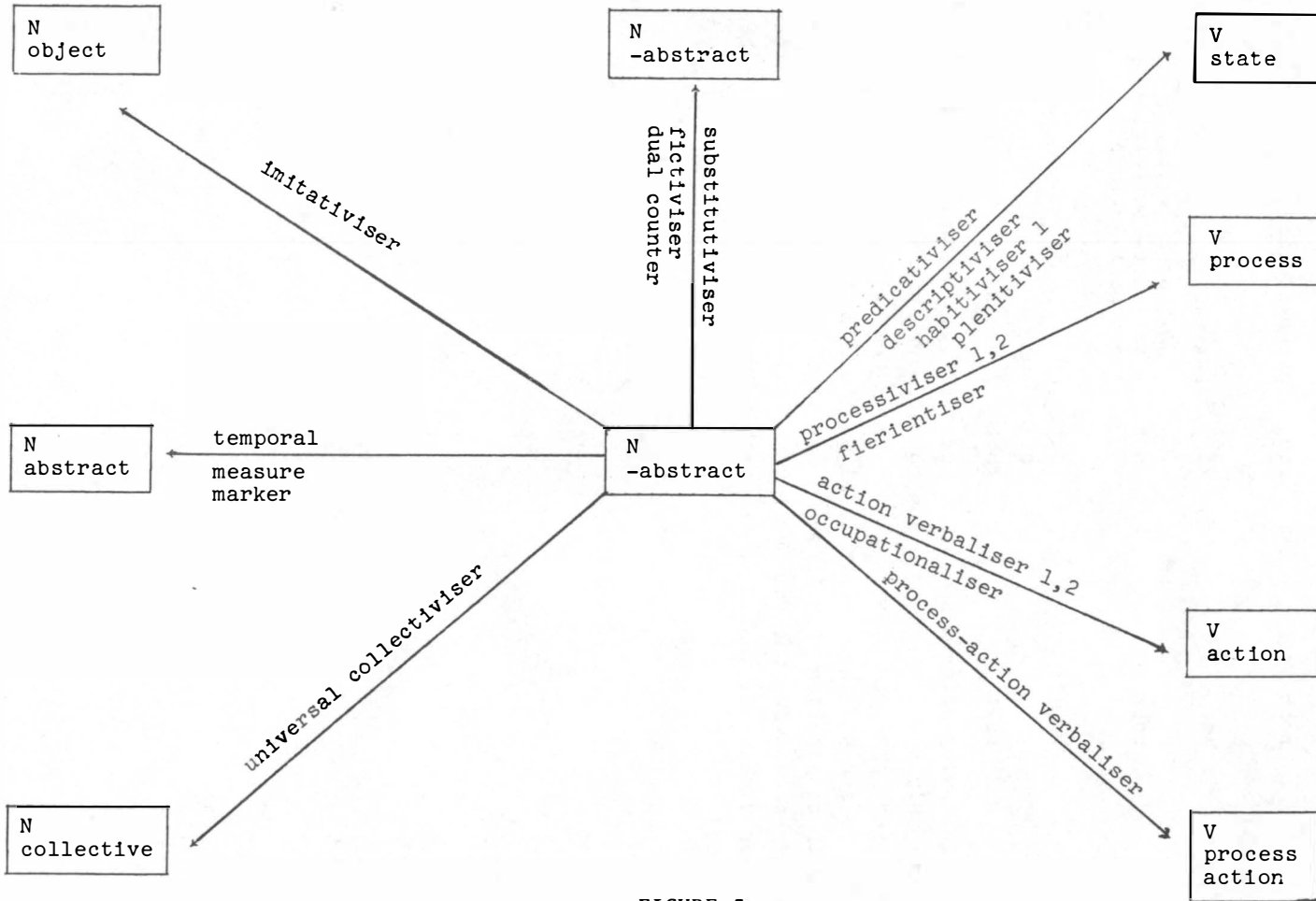

FIGURE 3

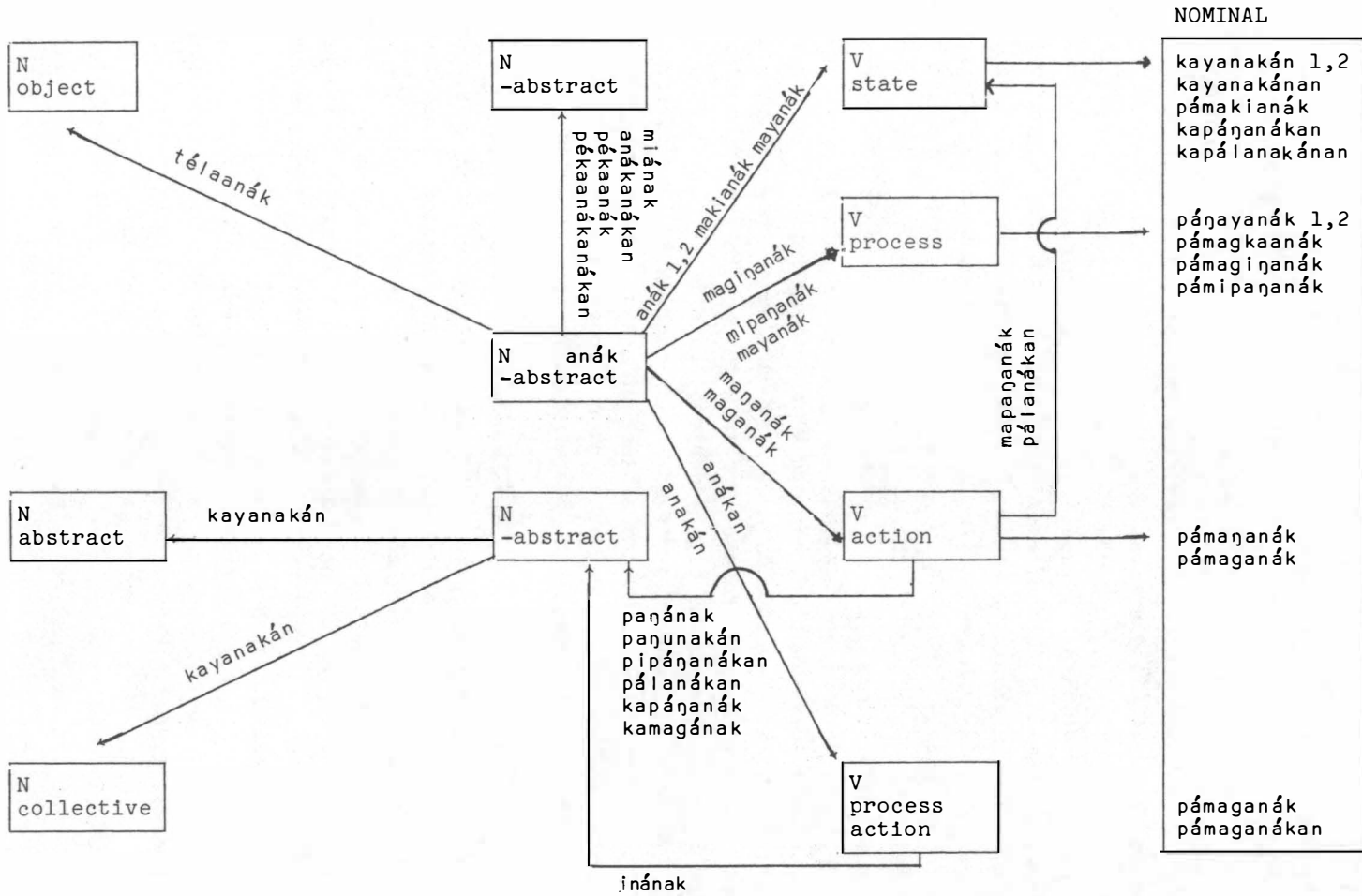

FIGURE 4

The preceding sketch of the derivational possibilities of *aná*k is far from complete. Each one of the derived V's from *aná*k is subject to the same type of selectional specification for V's outlined in sections 1.1.1 to 1.1.5, many selectional specifications being eventually symbolised by affixes, for example: causative, associative, participative, reciprocative, exertive, abilitative. Corresponding to each V is its correlative nominal which is dependent on the phonological shape of the V with its affixes.

Moreover, derived noun roots such as *iná*nak '*god-child*', *kapá*nanák '*associate in childbirth*', *kamagá*nak '*relative*', *pipá*nanákan '*maternity hospital*', *pá*lanákan '*birth tract*' are subject to their own derivational possibilities, although it would seem that unlike their basic root, the possibilities are much fewer. It is not clear, however, whether this constraint is a rule of the language or a constraint arising from reality, from 'knowledge of the world'.

The paths hypothesised are tentative. A more exhaustive study of different sub-sets of the lexicon will give a clearer picture. In the course of the investigation, various alternatives kept presenting themselves; the diagram eventually presented was judged the most simple and most economical and the one most in keeping with the assumptions of the theory. The status of the derived nouns is especially problematic. Perhaps such derived N's as *iná*nak '*god-child*' are synchronically units rather than concatenations of units, monolexicemic idioms which may then be treated as basic units such as *aná*k. Certainly, if this hypothesis is adopted, the alarming accretions of units postulated will be substantially reduced, at least for derived nouns.

That such paths exist seems incontrovertible. Moreover, that the treatment of the lexicon in an agglutinative language such as Pampangan demands a treatment of the kind outlined in this section seems clear. How to do this in the most economical and efficient and revealing way possible remains a problem. Certainly, it poses one of the most challenging aspects of Philippine and Austronesian linguistics. The problems are all the more formidable in a non-standardised language such as Pampangan, with its many dialects as well as lack of a literature, since the productivity of certain processes seems to be idiosyncratic for individual language users. Multiple instances of polysemy compound the problem, itself a result of the multiple possibilities already alluded to. Many of the forms set down are undoubtedly lexicabilia, that is, combinations which were formed according to the derivational rules of the language but which perhaps have as yet not been actually used by an enterprising language performer until now. The fact that the forms were generated according to the rules of the language makes

them comprehensible and acceptable to a native speaker. Until they are in general currency, these neologisms are unusual, of the same type as formatives in English such as *deobnoxify* (the example is McCawley's), *denoxify*, *antiquadrilateralism*, or even some of the Latinate labels proposed in this study. That such open-endedness obtains in the lexicon of a language has long been known. When new forms are generated, the acceptability of such forms would have to be investigated. Operational tests would have to be constructed to measure the acceptability of these forms (see Zimmer 1964 for some suggestions on testing productivity in derivation). Moreover, when certain forms are found to be unacceptable, it is necessary to see if the constraint operative arises from the rules of the language or from the hearer's 'knowledge of the world'.

### 1.2.3. Noun Inflectional Units

After N has been specified by a root, basic or derived, it must be further specified by semantic units which do not depend on the lexical selection of N but which may specify any lexical unit; these N units, like their counterparts in V, are inflectional units.

Certain of these units ('plural', 'total') have already been mentioned in connection with specifications which an N accompanying a V must have as a result of prior specification of V (for example, it was stated that a partitive N is always plural and total when it accompanies a state V inflected as superlative). There are still other inflectional units which must be described.

N may be inflectionally specified as plural:

- (1.2.3.1) *masantín ya # in anák* 'The child is pretty.'  
*masantín la # diñ ának* 'The children are pretty.'

where plural is symbolised by the determiner *diñ* and an accentual shift in the noun root. Plural specification is possible for N's which are not specified by a lexical unit but are instead specified by first and/or second person:

- (1.2.3.2) *masantín ku* 'I am good-looking.'  
*masantín kamí* 'We are good-looking.'  
*masantín ka* 'You are good-looking.'  
*masantín kayú* 'You (plural) are good-looking.'  
*masantín katá* 'You and I are good-looking.'  
*masantín támu* 'You (plural) and I are good-looking.'  
 'You and we are good-looking.'  
 'You (plural) and we are good-looking.'

Unique N's are intrinsically -plural. However, there is a way of marking such unique N's as plural but only if they have been priorly marked as associative, in which case they have the meaning 'So-and-so and [his/her/its] companions':

- (1.2.3.3) masantín ya # l Pédrú 'Pedro is good-looking.'  
 masantín la # dl Pédrú 'Pedro and [his] companions are good-looking.'

It is possible, of course, to say:

- (1.2.3.4) masantín la # dlñ Pédrú  
 'The persons named Pedro are good-looking.'

Here, however, Pédrú is no longer unique but by a derivational process, has become -unique, since one is no longer referring to an individual person but to a set of individuals having a common name.

An N, plural or -plural, may be specified as definite. Note the contrast in the two sentences:

- (1.2.3.5) atín # táu # kíñ baíé 'There is a man in the house.'  
 atí yu # in táu # kíñ baíé 'The man is in the house.'

in which the second instance of táu is definite. A definite N may be further specified as demonstrative:

- (1.2.3.6) mátas ya # itán táu  
 'That man (not near you nor me) is tall.'

A variant of (1.2.3.6) is:

- (1.2.3.6') mátas ya # in táun itá

Still another variant is:

- (1.2.3.6'') mátas ya # itán táun itá

In this discussion, only sentences of the type (1.2.3.6) will be considered. In sentence (1.2.3.6), itá is a symbolisation for definite demonstrative. Demonstrative may be specified further as proximate to speaker and/or proximate to hearer:

- (1.2.3.7) mátas ya # lnín táu  
 'This man (near me) is tall.'
- (1.2.3.8) mátas ya # lyán táu  
 'That man (near you) is tall.'
- (1.2.3.9) mátas ya # itín táu  
 'The man (near you and me) is tall.'

Non-definite N's may be specified further as generic (if V is generic) or partitive.

(1.2.3.10) maragúl ya # iη patíη

The above sentence is ambiguous:

*'The whale (a definite one) is big.'*

*'The whale (as a species) is big.'*

In both sentences, the state V is inflectionally marked as generic. In its second meaning, however, iη patíη is a symbolisation for *'the whale as a species'*, thus in effect making the whole statement a general statement. It seems, however, that when the unit 'generic' specifies a -plural N, N must be additionally specified as 'aggregate', since *'the whale as a species'* refers to whales considered as an aggregation. The fact that 'generic' is eventually literalised by 'definite' may be formulated as a post-semantic process. It is possible for a general statement to have a plural subject:

(1.2.3.11) maragúl la # déη patíη

*'Those whales (near you) are big.'*

*'Whales (in general) are big.'*

In general statements, when N is plural and generic, a post-semantic literalisation process occurs converting

[plural  
generic]

into [definite  
demonstrative  
proximate to hearer].

It is not only state V's which are accompanied by a generic N:

(1.2.3.12) gágapaη ya # iη úlad

*'The worm (a definite one) is crawling.'*

*'The worm (as a species) crawls.'*

(1.2.3.13) gágapaη la # déη úlad

*'Those worms (near you) are crawling.'*

*'Worms (in general) crawl.'*

As with state V's, for N to be generic, -state V must be generic. Generic in -state V's is post-semantically literalised as actual durative aspect.

For an example of -definite N specified as partitive, one may cite:

(1.2.3.14)1 méηan ya # kiη nási? # i Pédrú

*'Pedro ate [some portion] of the rice.'*

(1.2.3.15) méηan ya # kariη dalandán # i Pédrú

*'Pedro ate [some] of the oranges.'*

Partitive N's present a problem. It seems that when partitive occurs, an embedded V must be posited in semantic structure. Thus, the structure of (1.2.3.15) would seem to be:

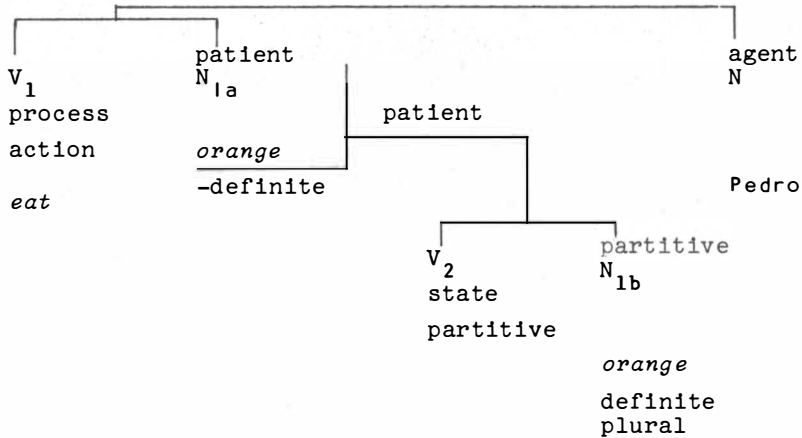

What this analysis tries to show is that the oranges which were eaten by Pedro are part of a larger batch of oranges which are pre-supposed as known by the speaker and hearer (hence, definite). The partitive state verb (V<sub>2</sub>) is seen then as a kind of relative clause attaching to N<sub>1a</sub>. In Chapter III, justification will be given for considering relative clauses as quasi-inflectionally specifying N further. Moreover, N<sub>1a</sub> is in a patient relation to V<sub>1</sub>; it is likewise in a patient relation to V<sub>2</sub>; the patient relation for ease of reading has been

placed above the N <sup>rel</sup> V<sub>2</sub> axis. A rule will be formulated subsequently whereby

N<sub>1</sub>  
count  
root  
-definite  
partitive

becomes

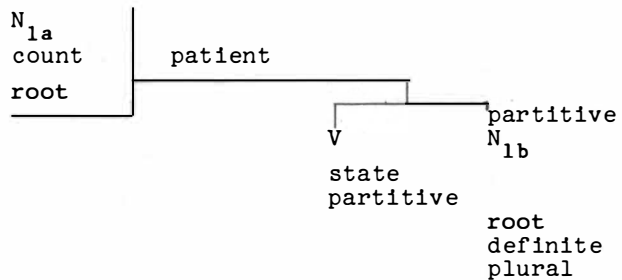

Post-semantically, the partitive state V is deleted; so is the N<sub>1a</sub> because of its redundance. Partitive N<sub>1b</sub> is likewise post-semantically marked as OBLIQUE. Hence, in sentence (1.2.3.15), the patient N is realised as  $\emptyset$  leaving only an oblique-marked partitive N, *kariṅ dalandán*.

The justification for considering partitive N's as arising in semantic structure from separate state V's is the occurrence in Pamangan of a sentence such as:

*karéni ia # déṅ dalandán a rén*  
*'Those oranges (near you) [are part of the batch*  
*of oranges] in this [place] (near me).'*

A similar configuration (non-lexically specified partitive state V accompanied by a partitive N and a patient N) must then be posited as embedded in N's specified as partitive.

A definite N may be specified further as total:

(1.2.3.16)\* *péṅan na naṅ Pédro # iṅ gaṅ nási? >*  
*péṅan naṅ Pédro # iṅ gaṅ nási?*  
*'All the rice was eaten by Pedro.'*

When N is selectionally specified as count, for it to be specified as total, it must be priorly specified as plural:

(1.2.3.17)\* *péṅan na ia naṅ Pédro # diṅ gaṅ daiandán >*  
*péṅan na iaṅ Pédro # diṅ gaṅ dalandán*  
*'All the oranges were eaten by Pedro.'*

It is possible to specify 'total' further as 'emphatic':

(1.2.3.16a) *péṅan naṅ Pédro # iṅ éganáganán nási?*  
 x *'The all-all food was eaten by Pedro.'* =  
*'Absolutely all the food was eaten by Pedro.'*

(1.2.3.17a) *péṅan na iaṅ Pédro # diṅ éganágandán dalandán*  
*'Absolutely all the oranges were eaten by Pedro.'*

If N is count and definite, it may be further specified as individuated:

(1.2.3.18) *mátas ya # iṅ báiaṅ métuṅ a anak a atí yu kéní*  
*'Each child who is here is tall.'*

where 'individuated' is symbolised by *báiaṅ métuṅ* 'each' (lit. *each one*).

If N is plural, it may be both total and individuated:

(1.2.3.19) *mátas ia # diṅ sabiaṅ anak a atí yu kéní*  
*'Each one of the children who are here is tall.'*

where  $\left[ \begin{array}{l} \text{total} \\ \text{individuated} \end{array} \right]$  is symbolised by \*sablá?

If N is -total and -individuated, it may be specified as either singular (if it is also count and definite) or quantitative:

- (1.2.3.20) mátas ya # iη bukúd a anák a atí yu kéní  
*'The only child who is here is tall.'*

where bukúd means 'only'. If N is specified as quantitative, it may be further specified as estimative or numerical (the latter only if N is selectionally count):

- (1.2.3.21) ménákit yaη dakál a anák # i Pédrú  
*'Pedro saw many children.'*

- (1.2.3.22) ménákit yaη dakál a pámaηán # i Pédrú  
*'Pedro saw much food.'*

where dakál symbolises both 'many' and 'much' and specifies estimative further. On the other hand, one may have:

- (1.2.3.23) ménákit yan aduáη ának # i Pédrú  
*'Pedro saw two children.'*

where aduá? specifies numerical further.

The specifications 'quantitative' and 'singular' are special in Pampangan, since when these occur, N must be replaced by an N with an attached relative clause, as with N's specified as partitive.

One can say in Pampangan:

- (1.2.3.24) dakál la # diη dalandán  
*'The oranges are many [in number].'*

- (1.2.3.25) aduá la # diη dalandán  
*'The oranges are two [in number].'*

- (1.2.3.26) bukúd ya # lη dalandán  
*'The orange is sole.' = 'The orange is by itself.'*

It seems then that quantitative estimates, numbers, and 'only' are state V's in Pampangan. Sentence (1.2.3.25) is clearly not an existential sentence, for if one wanted to say, 'There are two oranges', one would say:

- (1.2.3.27) atíη aduáη dalandán

Hence, for a sentence such as (1.2.3.23), the semantic configuration would be:

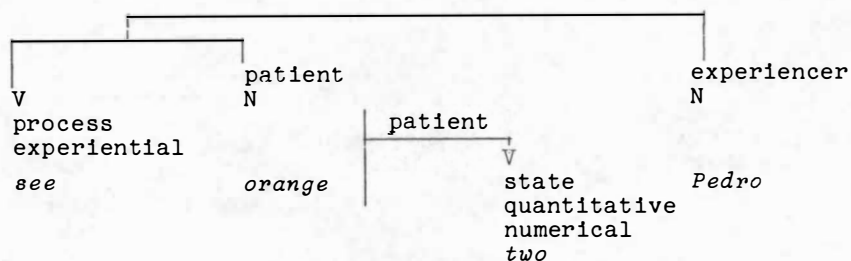

The embedded V functions as a kind of inflectional specification for the patient N. Structures of the above type will be discussed at greater length in Chapter III. For the moment, a semantic rule will

merely be postulated replacing

$$\begin{array}{c} \text{rel} \\ \text{N} \\ \left\{ \begin{array}{l} \text{quantitative} \\ \text{singular} \end{array} \right\} \end{array}$$

with

$$\begin{array}{c} \text{rel} \\ \text{N} \quad | \quad \text{patient} \\ \quad \quad \quad \downarrow \\ \quad \quad \quad \text{V} \\ \quad \quad \quad \left\{ \begin{array}{l} \text{state} \\ \text{quantitative} \\ \text{singular} \end{array} \right\} \end{array}$$

The generalisations on N inflectional units may be summarised by the following Semantic Noun Inflectional Rules (SNIR):

(SNIR 1) N - → plural  
-unique  
root

(SNIR 2) N - → associative  
unique  
root

(SNIR 3) N → plural  
unique  
root  
associative

(SNIR 4) N - → definite  
root

This rule is obligatory for unique N and for N specified as first and/or second person.

(SNIR 5) definite - → demonstrative

(SNIR 6) demonstrative - →  $\left( \begin{array}{l} \text{proximate to speaker} \\ \text{proximate to hearer} \end{array} \right)$

(SNIR 7) demonstrative - →  $\left\{ \begin{array}{l} \text{generic / V} \\ \text{partitive} \quad \text{generic} \end{array} \right\}$   
root  
-definite

(SNIR 8)	generic	→→	aggregate																					
(SNIR 9)	rel N (count) root -definite partitive	→	<table border="0"> <tr> <td>rel N (count) root -definite</td> <td></td> <td>patient</td> </tr> <tr> <td></td> <td></td> <td>partitive</td> </tr> <tr> <td></td> <td></td> <td>V state</td> </tr> <tr> <td></td> <td></td> <td>N &lt;(count)&gt;</td> </tr> <tr> <td></td> <td></td> <td>partitive root</td> </tr> <tr> <td></td> <td></td> <td>&lt;plural&gt;</td> </tr> <tr> <td></td> <td></td> <td>definite</td> </tr> </table>	rel N (count) root -definite		patient			partitive			V state			N <(count)>			partitive root			<plural>			definite
rel N (count) root -definite		patient																						
		partitive																						
		V state																						
		N <(count)>																						
		partitive root																						
		<plural>																						
		definite																						
(SNIR 10)	N (count) root <plural> definite	-→→	total																					
(SNIR 11)	total	-→→	emphatic																					
(SNIR 12)	N count root definite	-→→	individuated																					
(SNIR 13)	N root -total -individuated	-→→	<table border="0"> <tr> <td>{</td> <td>singular / N</td> <td>}</td> </tr> <tr> <td></td> <td>count</td> <td></td> </tr> <tr> <td></td> <td>definite</td> <td></td> </tr> <tr> <td></td> <td>definite</td> <td></td> </tr> <tr> <td></td> <td>quantitative</td> <td></td> </tr> </table>	{	singular / N	}		count			definite			definite			quantitative							
{	singular / N	}																						
	count																							
	definite																							
	definite																							
	quantitative																							
(SNIR 14)	quantitative	→→	<table border="0"> <tr> <td>{</td> <td>estimative</td> <td>}</td> </tr> <tr> <td></td> <td>numerical / N</td> <td></td> </tr> <tr> <td></td> <td>count</td> <td></td> </tr> </table>	{	estimative	}		numerical / N			count													
{	estimative	}																						
	numerical / N																							
	count																							
(SNIR 15)	rel N root {quantitative} singular	→	<table border="0"> <tr> <td>rel N root</td> <td></td> <td>patient</td> </tr> <tr> <td></td> <td></td> <td>V state</td> </tr> <tr> <td></td> <td></td> <td>{quantitative}</td> </tr> <tr> <td></td> <td></td> <td>singular</td> </tr> </table>	rel N root		patient			V state			{quantitative}			singular									
rel N root		patient																						
		V state																						
		{quantitative}																						
		singular																						

The preceding rules generate multiple N matrices; examples of the most common combinations generated will be given below:

N	atíη anak
-definite	
-plural	'There is a child [present].'
N	atíη anak
-definite	
plural	'There are children [present].'
N	mátas ya # i Pédru
unique	
definite	'Pedro is tall.'

N unique definite associative plural	mátas la # dl Pédru <i>'Pedro and [his] companions are tall.'</i>
N definite	mátas ya # lη anak <i>'The child is tall.'</i>
N plural definite	mátas la # dlη anak <i>'The children are tall.'</i>
N definite demonstrative	mátas ya # itán anak <i>'That child is tall.'</i>
N plural definite demonstrative	mátas la # détaη anak <i>'Those children are tall.'</i>
N definite demonstrative proximate to speaker	mátas ya # lníη anak <i>'This child (near me) is tall.'</i>
N plural definite demonstrative proximate to speaker	mátas la # dénlη anak <i>'These children (near me) are tall.'</i>
N definite demonstrative proximate to hearer	mátas ya # lyán anak <i>'That child (near you) is tall.'</i>
N plural definite demonstrative proximate to hearer	mátas la # déη anak <i>'Those children (near you) are tall.'</i>
N definite demonstrative proximate to speaker proximate to hearer	mátas ya # ltíη anak <i>'This child (near you and me) is tall.'</i>
N plural definite demonstrative proximate to speaker proximate to hearer	mátas ya # détiη anak <i>'These children (near you and me) are tall.'</i>

- N  
-definite  
generic  
aggregate  
maragúI ya # iŋ patíŋ  
'The whale (as a species) is big.'
- N  
plural  
-definite  
generic  
maragúI la # déŋ patíŋ  
'Whales (as a species) are big.'
- N  
-count  
-definite  
partitive  
méŋan ya # kiŋ nási? # Iŋ anák  
'The child ate [some] of the rice.'
- N  
count  
-definite  
partitive  
méŋan ya # kiŋ dalandán # Iŋ anák  
'The child ate [some] of the orange.'
- N  
count  
plural  
-definite  
partitive  
méŋan ya # kariŋ dalandán # Iŋ anák  
'The child ate [some] of the oranges.'
- N  
-count  
definite  
total  
péŋan na niŋ anák # Iŋ gaŋ nási?  
'All the rice was eaten by the child.'
- N  
-count  
definite  
total  
emphatic  
péŋan na niŋ ának # Iŋ éganáganán nási?  
'Absolutely all the rice was eaten by the child.'
- N  
count  
plural  
definite  
total  
péŋan na la niŋ anák # diŋ gaŋ dalandán  
'All the oranges were eaten by the child.'
- N  
count  
plural  
definite  
total  
emphatic  
péŋan na la niŋ anák # diŋ éganáganán dalandán  
'Absolutely all the oranges were eaten by the child.'
- N  
definite  
individuated  
mátas ya # Iŋ bálaŋ métuŋ a anák a atí yu kénI  
'Each child who is here is tall.'
- N  
plural  
definite  
total  
individuated  
mátas la # diŋ sabláŋ ának a atí yu kénI  
'Each and all of the children who are here are tall.'
- N  
count  
definite  
singular  
mátas ya # Iŋ bukúd a anák a atí yu kénI  
'The only child who is here is tall.'

N -count quantitative estimative	méŋan yaŋ dftak a nási? # iŋ anák <i>'The child ate a little rice.'</i>
N -count definite quantitative estimative	péŋan na niŋ anák # iŋ dftak a nási? a atí yu kéní <i>'The little rice that was here was eaten by the child.'</i>
N count plural quantitative estimative	méŋan yaŋ dakál a dalandán # iŋ anák <i>'The child ate many oranges.'</i>
N count plural definite quantitative estimative	péŋan na la niŋ anák # diŋ dakál a dalandán a atí yu kéní <i>'The many oranges which were here were eaten by the child.'</i>
N count plural quantitative numerical	méŋan yaŋ aduáŋ dalandán # iŋ anák <i>'The child ate two oranges.'</i>
N count plural definite quantitative numerical	péŋan na la niŋ anák # diŋ aduáŋ dalandán a atí yu kéní <i>'The two oranges which were here were eaten by the child.'</i>
N -count partitive quantitative estimative	méŋan yaŋ dftak kiŋ nási? # iŋ anák <i>'The child ate a little of the rice.'</i>
N count plural partitive quantitative numerical	méŋan yaŋ aduá kariŋ dalandán # iŋ anák <i>'The child ate two of the oranges.'</i>

#### 1.2.4. Classifiers

In Pampangan, such noun phrases as the following occur:

- (1.2.4.1) aduáŋ pátiŋ pále  
*'two measures (2.72 dry quarts) of unhusked rice'*
- aduáŋ buslúŋ sáŋlŋ  
*'two baskets (or more or less standard size) of bananas'*

aduán kapáris a bakyá?  
 'two pairs of wooden slippers'

(1.2.4.2) aduán búll a pále  
 'two grains of unhusked rice'

aduán píll a ságin  
 'two bunches (lit. twists) of bananas'

aduán kapútut a tinápe  
 'two slices of bread'

The above forms are obviously related and must be accounted for within a unified frame of reference. The phrases may be characterised by the following semantic matrices:

(1.2.4.1)	N	N	N
	-abstract	-abstract	-abstract
	(containable)	count	count
	<i>unhusked rice</i>	(containable)	(pairable)
	quantitative	<i>banana</i>	<i>wooden slipper</i>
	numerical	quantitative	quantitative
	two	numerical	numerical
	measure	two	two
	2.72 dry quarts	measure	counter
		basket of	dual
		standard size	
(1.2.4.2)	N	N	N
	-abstract	-abstract	-abstract
	-count	count	count
	granular	bunched	sliceable
	<i>unhusked rice</i>	torquable	<i>bread</i>
	quantitative	<i>banana</i>	quantitative
	numerical	quantitative	numerical
	two	numerical	two
	counter	two	counter
	(singulary)	counter	(singulary)
		indefinite	
		number	

In discussing the possible specifications of N in the preceding sections, no effort was made to be exhaustive in the list of specifications for selectional and inflectional categories. As the above matrices show, in accounting for classifiers, certain specifications must be added to the inventory postulated thus far. It would seem that in the semantic generation of matrices such as the above, certain selectional specifications of N which would normally be unmarked because not absolutely necessary for lexical selection are highlighted, for example, that unhusked rice is granular, that bananas are bunched and torquable (twisted off in bunches from the tree trunk), that bread is sliceable. Features such as 'containable' and 'pairable' are perhaps implied by the specifications '-abstract' and 'count' and therefore need not be marked because redundant; hence, the use of parentheses. Moreover, it would

seem that any -abstract N may be inflectionally specified by 'measure' and any count N may be inflectionally specified by 'counter'. In turn, both 'measure' and 'counter' may be further specified by quantitative specifications special to a culture (in the Philippines, baskets of various sizes are used as measures of fruits and vegetables, and containers (wooden or metal of various sizes) are used as measures of grain; counters (specified as sets of two, sets of twelve, sets of twenty, etc.) are perhaps near-universals.

A singular counter, in Pampangan symbolised by ka-, for a set of one may be taken as the unmarked specification of counter; any set larger than one would then be marked: dual, trial, quadral, quintal, decimal, duodecimal, vigesimal, etc. These numeral specifications are over and above the numerical specifications postulated in section 1.2.3; thus, one can speak of 'two sets of two' or 'two pairs' or of 'two sets of twenty'.

Post-semantic processes linearising the N matrix into a three-branched configuration will be formulated in Chapter II. The surface structure output of such processes would then be:

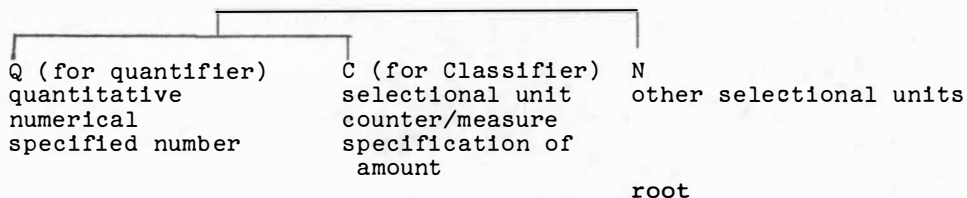

Hence, the semantic analysis of the classifiers exemplified in (1.2.4.1) and (1.2.4.2) is as follows:

- (1.2.4.1) C  
 -abstract  
 (containable)                      symbolised by páti  
 measure  
 2.72 dry quarts
- C  
 -abstract  
 (containable)                      symbolised by busiú?  
 measure  
 basket of  
 standard size
- C  
 count  
 (pairable)                          symbolised by kapáris  
 counter                              (from Spanish pares)  
 dual
- (1.2.4.2) C  
 granular  
 counter  
 (singular)                              symbolised by búti

C  
 bunched  
 torquable  
 counter  
 indefinite set  
 symbolised by pŕlŕn

C  
 sliceable  
 counter  
 (singular)  
 symbolised by kapŕtut

Classifiers of the type exemplified by (1.2.4.2) are much more numerous in Malay (see Lewis 1965) than in Pampangan. Malay classifiers, however, may be analysed within the same frame of reference. In Malay, whenever N is inflectionally specified as 'quantitative' and 'numerical', it must be additionally specified inflectionally by a counter (singular) which, combined with a highlighted selectional unit, is directly symbolised by a numerical classifier. As in Pampangan, which has comparable selectional units, a particular unit is factored out and highlighted; in Malay, many of these selectional units likewise figure prominently in a folk taxonomy. Moreover, this highlighting process is obligatory. Thus, whereas in Pampangan, one says:

aduán matsŕn            *'two monkeys'*

one must say in Malay

dua ekor kŕra            <sup>x</sup>*'two tail monkey' =*  
                              *'two monkeys'*

ekor is a classifier for all animals; by synecdoche, however, a unit 'caudal' is specified of animate -human N's and is used as a criterial specification for the classifier. Thus, the semantic characterisation of the Malay noun phrase is:

N  
 count  
 animate  
 caudal  
 monkey  
 quantitative  
 numerical  
 two  
 counter  
 (singular)

Post-semantically, to generate C, 'caudal' and 'counter (singular)' are factored out to form a separate branch:

C  
 caudal  
 counter  
 (singular)  
 symbolised by ekor

In Malay folk taxonomy, after the initial division into animate and inanimate, animate is further sub-divided into human and non-human. On the other hand, inanimate is further sub-divided into various sub-categories according to geometric shape. Remnants of this taxonomic classifier system are found in Pampangan. Besides such classifiers in Pampangan as píllŋ lit. 'twist' (since Bergaño's time, used almost exclusively for bananas), búttl 'grain' (cf. Malay butir), kapútut 'slice' (cf. Malay potong), kapirásu 'piece' (from Spanish pedazo; comparable with Malay biji), which are based on specifications lower in the folk taxonomy, there is also katáu 'person' (comparable with Malay orang) and analysable as

C  
human  
counter  
(singular)

In Contemporary Pampangan, however, katáu is used only in questions, píllán katáu 'How many persons?' In another Philippines language, Hiligaynon, one finds kabflug 'piece' instead of kapirásu; kabflug is analysable as

C  
-animate  
object  
round  
counter  
(singular)

and attests to the use of geometric dimensions in characterising non-animate N's.

Besides taxonomic classifiers (elaborated in Malay and attenuated in Pampangan) as well as universal counters and measures based on more general selectional specifications such as 'count' and '-abstract', there are likewise special counters for objects of particular importance to the culture in many of the Austronesian languages, particularly, in the languages of the Polynesian branch. At one time, there must have been, at least in certain dialects, an elaborate set of such counters in Pampangan, for to the query, 'Hay diversos modos de contar según la clase de cosas como cocos, petates, pescados [,] canoas, frutas [,] etc. [.]?' Bravo (1886b:27) responds: 'Muchísimas clases que por falta de lugar no las enumero'. Bravo lived in Candaba (see Map 2) where apparently these counters had been in use. In the dialects examined for this study, however, no such counters were elicited; judging from Bergaño's silence on this point, it seems that the eighteenth century Bacolor dialect described by Bergaño did not have them either.

In any case, such special counters are easily accounted for within the same frame of reference proposed. To take only one subset of examples from Hawai'ian (see Alexander 1965:13-14): Hawai'ian has a symbolisation for the number 'forty', *kanaha*. In referring to 'forty tapas' or 'forty canoes', however, one uses *iako* and in referring to 'forty fish', one uses *ka'an*. Presumably, one can speak of 'two sets of forty tapas/canoes' and 'two sets of forty fish'. The matrices for such N's may be represented thus:

N	N
count	count
-animate	animate
object	
<i>tapa/canoe</i>	<i>fish</i>
quantitative	quantitative
numerical	numerical
two	two
counter	counter
forty	forty

Unlike taxonomic classifiers and ordinary counters and measures, however, special counters do not factor out a selectional unit but the lexical unit itself:

C	
<i>tapa/canoe</i>	symbolised by <i>iako</i>
counter	
forty	
C	
<i>fish</i>	
counter	symbolised by <i>ka'an</i>
forty	

In the process of linearisation, the lexical root is transferred into the C branch, thus in effect leaving the N branch without a lexical specification; in Chapter II, it will be shown that there is a general rule deleting matrices consisting solely of selectional units; hence, the N branch becomes  $\emptyset$ .

In summary, classifiers have been divided into three sub-types in this section and have been discussed within a common frame of reference. The three sub-types are: (1) ordinary measures and counters based on general selectional specifications such as '-abstract' and 'count' as criterial attributes; ordinary measures and counters are most likely universal in the sense that every language has such a subset of counters and measures but with culture-bound specifications; (2) taxonomic classifiers or (singularly) counters based on criterial selectional units which figure prominently in folk taxonomies (in Malay, taxonomic classifiers are obligatory if N is inflectionally specified as 'quantitative' and 'numerical'); (3) special counters or names of sets (of varied

numeral specification) of items important to a culture. Classifiers necessitate inflectional specifications 'counter' or 'measure' and for taxonomic classifiers, the highlighting of an implied specification by the addition of a criterial selectional unit. Post-semantically, the N matrix is linearised into a three-branched configuration,

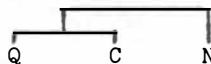

N; under C are the criterial selectional units as well as the inflectional units 'counter' or 'measure' and their specifications; the C matrix is eventually symbolised by the so-called 'taxonomic classifiers'. What differentiates the three types of classifiers seems to be the generality of the criterial selectional units eventually factored out. Where ordinary counters and measures use as their criterial selectional unit such general specifications as '-abstract' and 'count', taxonomic classifiers use less general specifications such as 'animate' 'human', and for '-animate' and '-human' N's, such dimensions as 'round', 'elongated', and other specifications based on geometric shape. Least general of all are such criterial units factored out for the special counters, lexical units in their own right.

The analysis proposed develops the programmatic suggestions of Chafe 1970a (see page 58) and integrates the techniques of componential analysis (Goodenough 1956) within a total grammar.

That Pampangan must have had at one time some more elaborate system of taxonomic classifiers seem to be clear; on the other hand, it is less clear whether or not it ever had the same degree of elaboration that Classical Malay displays in this area. The elaboration of the Classical Malay numeral classifier system seems to be the product of an artistic mannerism which may have been peculiar to Malay Culture.

If Bravo's response is well-founded, then Pampangan must have had at one time, in addition to the taxonomic classifiers, an elaborate set of special counters comparable to the sets found in many of the languages of the Polynesian branch.

Whether or not the classifier system belonged to Proto-Austronesian is an altogether different problem. The similarities of the dimensions necessary for the analysis of the different classifier systems which have been discovered in the languages not only of the Pacific Islands but likewise of the Asian and Western American mainland make the diffusion hypothesis more plausible than the genetic one.

To account for the classifiers in Pampangan (sub-types 1 and 2), the following semantic rules have been formulated to supplement the rules of sections 1.2.1 and 1.2.3. (The rules will not be numbered, however.)

(S )	N	->>	{ granular / N
	object		-count }
			frangible
			sliceable
			round }
(S )	N	->>	[ bunched
	object		torquable ]
	fruit		
(S )	N	->>	{ measure / N
	root		-abstract }
	quantitative		
			counter / N
			count }
(S )		>>	{ 2.72 dry quarts
	measure		basket (varied sixes)
			wooden square box
			metal milk-can
			... }
(S )		->>	{ dual
	counter		... }
			duodecimal
			... }
			indefinite set

### 1.3. New/-New Information

After the  $\overline{V N}$  configuration has been fully specified for selectional, lexical, and inflectional units, V and any accompanying N's must be further specified as either new or -new (old) information, depending on the preceding linguistic context. It will be seen in Chapter II that marking for new or -new is crucial for post-semantic processes of subjectivisation and possible deletion.

As the replacement rules in section 1.1.6 have been formulated, it is possible to have a semantic configuration of a V with four accompanying N's in a maximally specified V sub-type. The various replacement rules give rise to the following configuration:

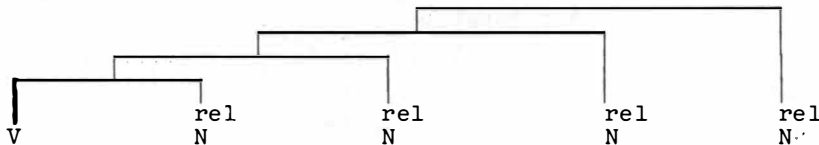

An example of a maximally specified V is

V  
 action  
 causative  
 completable  
 benefactive  
*give + causativiser*

To the question:

- (1.3.1) nánu # iŋ maliliyári  
'What is [that which is] happening?'

Or the question:

- (1.3.2) makanánu  
'How?' = 'What's happening?'

the response could be:

- (1.3.3) pápabiyé yaŋ kuálta # kiŋ anák # kaŋ Suán # i Pédrú  
'Pedro is causing Juan to give money to the child.'

(\*pa+biyay 'to cause to give' (lit. give + causativiser), from UA \*bəyaj, kuálta 'money', from Spanish cuarta), in which V and all four accompanying N's are new information. Were the sentence uttered in initial discourse, one would have the same distribution of new information:

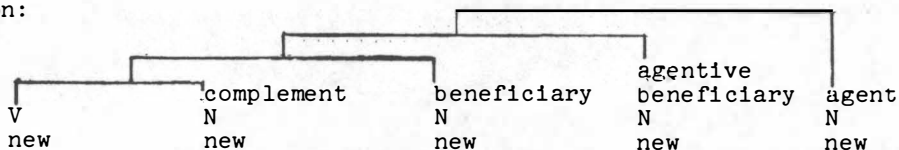

On the other hand, one may have the following sentence sequence in the course of a discourse:

- (1.3.4) mináus ya # i Pédrú ##  
pápabiyé yaŋ kuálta # kiŋ anák # kaŋ Suán # i Pédrú  
'Pedro called.'  
'Pedro is causing Juan to give money to the child.'

where now the agent N of the second sentence is -new information. Thus, the distribution of new and -new information is now:

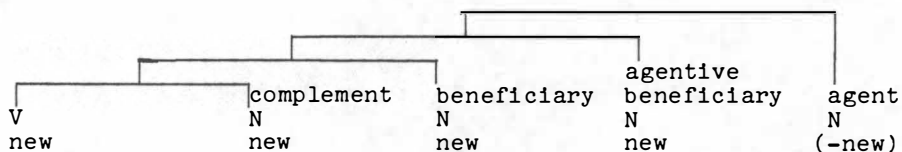

where (-new) means unmarked. It is not only the agent N which may be -new, however, as the following sentence sequence shows:

- (1.3.5) dínatán ya # i Suán ##  
\* pa+mag+bigáy+an na ya naŋ Pédrú+ŋ kuálta #  
kiŋ anák # i Suán >  
pápagbigáyan naŋ Pédrún kuálta # kiŋ anák # i Suán  
'Juan came.'  
'Juan is being caused by Pedro to give money to the child.'

(bigáy is probably a loanword from Tagalog, since the usual reflex of UA \* $\gamma$  in Pampangan is  $\gamma$ ), where now the agentive beneficiary N is -new information. Thus, the distribution of new and -new information is now:



On the other hand, the following sentence sequence may occur:

- (1.3.6) mákalúnus ya # iŋ anák ##  
 \* pá+pa+dínan na ya naŋ Pédru+ŋ kuálda # kaŋ  
 Suán # iŋ anák >  
 páparínan neŋ Pédruŋ kuálda # kaŋ Suán # iŋ anák  
 'The child is pitiful.'  
 'The child is being caused by Pedro to be given money  
 to by Juan.'

(parínan 'to cause to be given'; dínan is another root for 'give' and is preferable to \*biyáy in a configuration of this sort). In this sentence, it is the beneficiary N which is -new information, yielding the configuration:

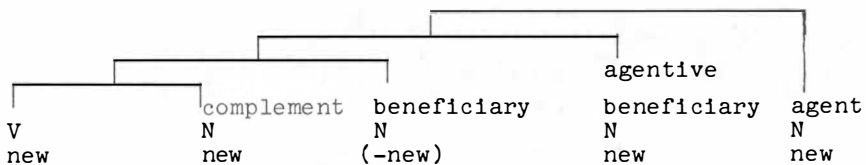

Or the complement N may be -new, as in the sequence:

- (1.3.7) ó iní # iŋ kuálda ##  
 pá+pa+biyáy na ya naŋ Pédru # kiŋ anák #  
 kaŋ Suán # iŋ kuálda >  
 pápabiyé neŋ Pédru # kiŋ anák # kaŋ Suán # iŋ kuálda  
 'Lo here is the money.'  
 'The money is being caused by Pedro to be given to  
 the child by Juan.'

where now the distribution of -new and new information is:

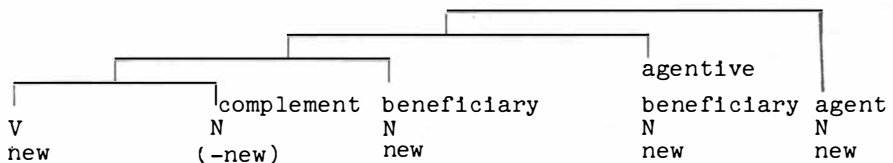



## 1.4. TOPIC

Consider the sentence:

- (1.4.1)      b́biyé yaŋ kuáita # kaŋ Suán # | Pédrú ~  
               babiyé yaŋ kuáita # kaŋ Suán # | Pédrú  
               '*Pedro is giving [some] money to Juan.*'

The subject of the sentence is Pédrú, marked by subject determiner | (in for [-human] N's). The process of subjectivisation, which seems to depend at least in certain contexts on the distribution of new and -new information, will be discussed at great length as a post-semantic process (in Chapter II). Consider, however, the following sentence:

- (1.4.1a)     | Pédrú # babiyé yaŋ kuáita # kaŋ Suán  
               '*As for Pedro, he is giving [some] money to Juan.*'

In the above sentence, the subject noun phrase is preposed; in ordinary Pampangan sentences, V, the most important item in a sentence, comes first and is followed by one or more N's. However, this unmarked linearisation may be disturbed by fronting one of the N's, in effect, making this fronted N the most important item in the sentence, instead of V. In this study, this type of highlighting will be labelled 'topicalisation' and is to be kept distinct from 'subjectivisation'. If an N is to be highlighted or specified as 'topic', it would seem that this should be indicated in semantic structure rather than post-semantically, since, in effect, such highlighting is a feature of the message or semantic content of an utterance rather than a by-product of preposing processes; in other words, the claim is made that highlighting does not follow as a result of preposing but that N may be specified as 'topic' and it is because it is thus specified that it is preposed. Hence, the post-semantic process of preposing is a result of semantic specification 'topic'.

In sentence (1.4.1a), | Pédrú is both subject and topic. It should be emphasised, however, that subject is distinct from topic, as the following example will show more clearly:

- (1.4.1b)     kaŋ Suán ya babiyé kuáita # | Pédrú  
               '*It is to Juan that Pedro is giving money.*'

where now it is the beneficiary N which is marked 'topic' and preposed, while the subject agent N is in its usual position in surface structure. (Note that when a phrase marked by kaŋ/kiŋ is preposed, the copier ya 'he' (co-referential with Pédrú) is interposed between the topic phrase and V.)

In sentence (1.4.1), it is not possible to topicalise the third N, the complement N *kuáлта*, which is -definite; a necessary context for topicalisation is definite specification. It is possible to say:

- (1.4.2)\* *kuáлта # iη babiyé na naη Pédru kaη Suán >*  
*kuáлта # iη babiyé naη Pédru kaη Suán*  
*'That which is being given by Pedro to Juan is money.'*

with sentential emphasis on 'money', but the above sentence is a stative sentence with a predicate N and is an altogether different configuration from sentence (1.4.1). However, if in sentence (1.4.1), the complement N were definite, it would be subjectivised and then apt for further topic specification:

- (1.4.1c)\* *bibiyé na ya naη Pédru # kaη Suán # iη kuáлта >*  
*babiyé neη Pédru # kaη Suán # iη kuáлта*  
*'The money is being given to Juan by Pedro.'*  
*iη kuáлта # babiyé neη Pédru # kaη Suán*  
*'As for the money, it is being given to Juan by Pedro.'*

The latter occurrence of preposing is of the same type as the preposing exemplified by (1.4.1a).

Moreover, to corroborate the earlier claim that topicalisation is independent of subjectivisation, one may consider the following examples of subjectless sentences (which will be discussed further in Chapter II):

- (1.4.3)\* *páka+lákad na naη Pédru > pákalákad naη Pédru*  
*'Pedro exerts himself in walking.'*  
 (1.4.4)\* *ka+lákad+lákad na pá? mu? naη Pédru >*  
*kalákadlákad na pa muη Pédru*  
*'Pedro has just now walked.'*  
 (1.4.5)\* *ka+santín na naη Pédrut > kasantín naη Pédrot*  
*'How good-looking Pedro is!'*

(The rising intonation in the latter sentence is the phonological context for the u > o shift in *Pédro*.) Now, it is possible to specify the accompanying N of each of the preceding three sentences as 'topic'. One then has:

- (1.4.3a) *i Pédru # pákalákad na*  
*'As for Pedro, he is exerting himself in walking.'*  
 (1.4.4a) *i Pédru # kalákadlákad na pá mu?*  
*'As for Pedro, he has just now walked.'*

- (1.4.5a) i Pédrú # kasantín nat  
 'As for Pedro, how good-looking he is!'

where -subject definite N is marked 'topic' and is preposed. There is a post-semantic process replacing naŋ/niŋ with i/iŋ when the N is fronted, in effect replacing -subject by subject; but this is a secondary type of subjectivisation which results from topicalisation. Note that the copier .na in each case remains -subject and is not replaced by ya. Earlier, it was stated that any definite N, subject or non-subject, may be specified as topic and then preposed. Hence, the non-subject but definite agent N in sentence (1.4.1c) may be topicalised:

- (1.4.1d) i Pédrú # babiyé ne # kaŋ Suán # iŋ kuáŋta  
 'As for Pedro, the money is being given by him to Juan.'

The sentence is interesting, since in effect, it has two subjects, the first subject being kuáŋta and the second subject (by secondary subjectivisation resulting from topicalisation and preposing) Pédrú.

Earlier, too, the connection between new and -new specification was mentioned as a possible context for subjectivisation. While new and -new specification is tied in with subjectivisation, it is irrelevant to topicalisation, since both new N's and -new N's may be topicalised. It is difficult to imagine contexts of -new N which need to be topicalised. For example, in a sequence such as:

- (1.4.6) dínatán ya # i Pédrú ##  
 Ífnuklúk ya (# i Pédrú)  
 'Pedro arrived.' '[Then] he sat down.'

it would be unnatural to topicalise the second occurrence of Pédrú (which is new and eventually deleted):

- (1.4.6')<sup>?</sup> dínatán ya # i Pédrú ##  
 i Pédrú # Ífnuklúk ya  
 ? 'Pedro arrived.' '[Then] As for Pedro, he sat down.'

However, in a discourse, it is entirely plausible to introduce an N, make several statements not relevant to N, and then to return to N (-new) by topicalising it:

- (1.4.6a) dínatán ya # i Pédrú ## ...  
 i Pédrú # Ífnuklúk ya  
 'Pedro arrived ... .' 'As for Pedro, he sat down.'

where now i Pédrú is -new but topic. In such an instance, topic specification blocks deletion: a topicalised -new N cannot be deleted although a subjectivised -new N not only is deletable but often is deleted.

The relevant topicalising rule may be formulated thus:

(Sl.4.1) N                    - →                    topic  
                   definite

Before concluding this section on topicalisation, it is necessary to make a remark on contrastive sentences in Pampangan. In English, it is possible to say:

*'Juan is as tall as Pedro.'*

where the two N's receive equal accent. In Pampangan, one would say:

(1.4.7)\* kasíŋ kattaʔás na ya naŋ Pédrú # í Suán >  
                   kasíŋ kátas        neŋ                    Pédrú # í Suán

where the main sentential accent is not on Pedro nor on Juan but on the verb root. One may topicalise either N:

(1.4.7a) í Suán # kasíŋ kátas neŋ Pédrú  
                   'As for Juan, he is as tall as Pedro.'

(1.4.7b) í Pédrú # kasíŋ kátas ne # í Suán  
                   'As for Pedro, Juan is as tall as he is.'

There seems to be no way of giving equal sentential accent to Suan and Pédrú, since there is a decided drop in pitch after a topicalised N. Hence, although in surface structure, sentence (1.4.7a) seems to parallel in word order the English equivalent, the pitch configuration is altogether different"

$$\frac{\text{N}}{\text{topic}} \# \text{_____}$$

The only instances discovered in which two N's received equal sentential accent were in sentences such as:

(1.4.8) í Pédrú # ampó # í Suán # # méko la  
                   'As for Pedro and as for Juan, they left.'

Sentences such as the above will be analysed in Chapter III as two-verb configurations, so that in effect, sentence (1.4.8) has two topics which originally came from two separate sentences such as:

(1.4.9) nínu # in mas mátas # # í Pédro† # o # í Suán  
                   'Who is [he who is] taller, Pedro or Juan?'

where either Pédrú or Suán will fill in the missing information in nínu. Since nínu is a predicate noun in an equational sentence, the sentential accent it receives is perfectly regular; so is the sentential accent on its would-be 'fillers', Pédrú and Suán. (The rising intonation at the end of í Pédrú will be discussed in Chapter III.)

Hence, in Pampangan, because of the constraint that only one N may be topicalised (and fronted) in a single V configuration, there seems to be no way of symbolising N's in comparison or contrast by means of equal sentential accent; rather, comparison and contrast is symbolised by affixation in the verb root ('equative', 'comparative'), which likewise receives the main sentential accent.

### 1.5. SUMMARY

By way of summation, to show how the semantic processes described thus far generate a well-formed semantic structure, the following Pampangan sentence will be derived step by step:

- (1.5.1)\* máki+biyáy laŋ digálu # ka+diŋ ának # di Pédrú #  
 ka+diŋ bábayi >  
 mákibiyé laŋ digálu # kariŋ ának # di Pédrú #  
 kariŋ bábayi  
*'Pedro and his companions are joining the women  
 in giving gifts to the children.'*

(makibiyé 'to join in giving' (lit. give + associativiser), digálu 'gift' from Spanish regalo, ának 'children', bábayi 'women').

The numbers in parentheses (#) indicate the step; to the left is the output of the rule which is listed to the right. (The rules on pages 52-5, 66-7, 73, 75, 77-8, 84-5, 89-90, 96-7, 107-8 should be consulted.)

V	RULE
action	(1) S1.1
associative	(2) S1.5
completable	(3) S1.5
benefactive	(4) S1.6
<i>give + associativiser</i>	(5) Lexical Rule
actual	(6) SVIR 8
durative	(7) SVIR 9
	(8) S1.12

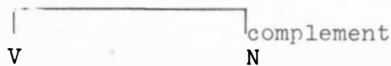

(9) S1.16

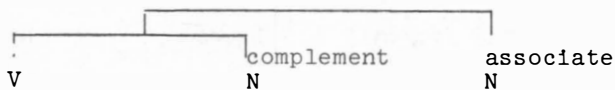

(10) S1.25

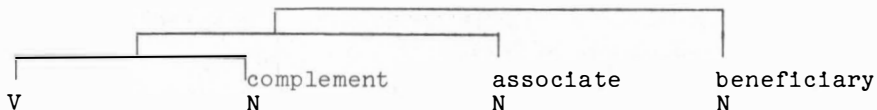

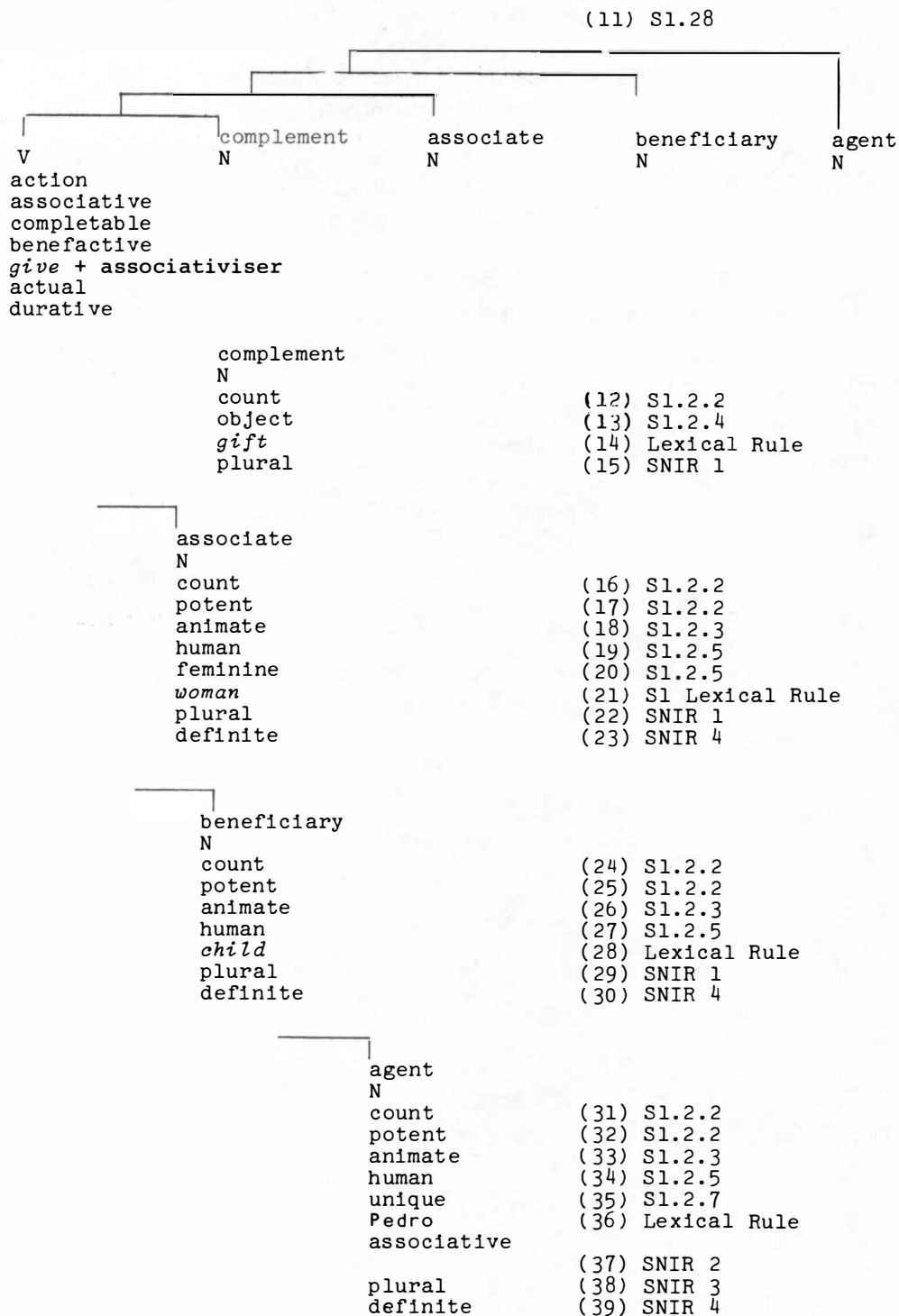

The semantic structure of the sentence may be represented thus: (It should be emphasised at this point that the semantic representation, although represented in a left-to-right order because of the two-dimensional limitations of all writing, is non-linear; it is best to imagine the semantic representation as a kind of mobile, four branches (or semantic axes) interconnected with V as a point of origin.)

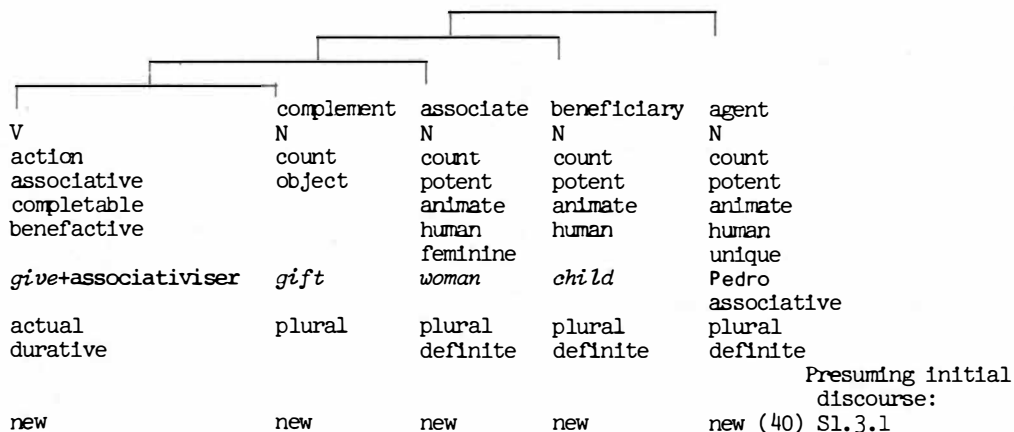

The post-semantic processes necessary to derive the above semantic structure into a surface structure will be described in the final section of Chapter II.

## CHAPTER II

### POST-SEMANTIC PROCESSES

#### 2. INTRODUCTION

In this chapter, processes which transform semantic configurations generated by the rules of Chapter I into linear surface structures apt for symbolisation will be described. These processes, called 'post-semantic processes', are 'analogous to the transformations of syntactical theory' (Chafe 1970b:582): they add, subtract, or replace specifications of V and N and finally linearise the structure into a surface structure.

There are eight sections in this chapter. The first seven sections describe main post-semantic processes relevant to Pampangan; such processes include what is language-specific in the grammar of a particular language, in contrast to the semantic rules, which up to a certain degree of delicacy (the term is Halliday's, 1961) of distinction are common to languages. It will be seen, however, that although such post-semantic processes are language-specific, their features and functions find analogues in other languages. Such post-semantic processes, in a complete grammar, must be ordered; in most cases, one rule provides the necessary context for the application or non-application of a subsequent rule. In an outline such as this, however, the order of post-semantic processes is suggestive rather than definitive. In fact, in the discussion of certain processes, where relevant, subsequent processes which do not immediately follow are discussed for the sake of the exposition. Moreover, as one studies any language in detail, one will no doubt discover additional post-semantic processes necessitated by certain configurations; hence, the processes outlined here make no claims to a complete inventory. The claim is made, however, that the processes described represent the

main types of post-semantic processes; other processes which may be discovered subsequently can be subsumed under these types.

In Chapters III and IV, where sentences other than simple statements are discussed and where structures with more than one V are outlined, other post-semantic processes will be necessary to finally derive the surface structures of such complex configurations. The processes described in this chapter are then relevant only to the types of sentences which have been cited in Chapter I.

The final section summarises the rules by setting them down in a tentative order and exemplifies the application of these rules by transforming the semantic configuration of the sentence generated at the conclusion of Chapter I into a surface structure.

### 2.1. SUBJECTIVISATION

Every sentence in Pampangan, except for certain contexts to be noted, demands a noun which is subjectivised; the subject N is marked by determiner *i/iŋ*. Subjectivisation, it has been stated in Chapter I, must be distinguished from topicalisation. In using the traditional label 'subject', the study differs in nomenclature from the work of the Summer Institute of Linguistics analysts, who use 'focus' instead of 'subject', although the distinction between subject and topic has been noted in the tagmemic literature under different labels (see, for example, Austin 1966, who discusses 'attention, emphasis, and focus' in Ata Manobo). The studious avoidance of the term 'focus' and the use of the term 'subject' will be justified in the course of the discussion. The development of the notion of subjectivisation in this section develops certain seminal ideas on this point suggested by Fillmore (1968), and finally, in its use of the semantic specification *new* and *-new* as one context for subjectivisation, this section is based on Chafe 1970b (see Chapter 15).

It has been observed that in the Philippine languages, there are as many subjectivisation possibilities as there are accompanying N's. The citations given in Chapter I, section 1.3, seem to exemplify this apparent freedom of choice. For ostensive purposes, the following paradigm may be cited (in this section, the subject N will be written in bold letters):

- (2.1.1)      *múmugsé yaŋ bóla # kiŋ anák # Iŋ TÁU*  
                   *'The man is throwing a ball to the child.'*

(\**m+ugsáy* 'to throw' (lit. *throw* (noun) + *activativiser*), *bóla* 'ball', from Spanish *bola*, *anák*, 'child', *táu* 'man').

- (2.1.1a)\* ugsáy+an na ya+ŋ bóla niŋ táu # Iŋ anák >  
 ugsen neŋ bóla niŋ tau # Iŋ ANÁK  
*'The child is being thrown a ball by the man.'*
- (2.1.1b)\* i+ugsáy na ya niŋ táu # kiŋ anák # iŋ bóla  
 yúgsé ne niŋ táu # kiŋ anák # Iŋ BÓLA  
*'The ball is being thrown to the child by the man.'*

What is necessary to determine is the context that gives rise to the choice of one N rather than another as subject, to incorporate the context into a rule, and then to observe what other post-semantic processes such subject specification triggers. Moreover, it is necessary to investigate too whether or not this choice is always possible.

### 2.1.1. Subjectless Sentences

Before dealing with subjectivisation, one must first consider instances of sentences where there is no subject, as in:

- (2.1.1.1) madalumdúm *'It is dark.'*
- (2.1.1.2) dádaiumdúm *'It is getting dark.'*

Both V's, the first a state V, the second a process V, are ambient and because ambient, are not accompanied by any N; if they are, such N's are ultimately traceable in semantic structure to other  $\overline{V}$  N configurations. Hence, the question of subjectivisation does not even arise in these sentences.

Again, consider the sentence:

- (2.1.1.3) atín táu  
*'There is a man present.'*

where atín is a presential state V. Now, táu 'man' is inflectionally specified as -definite. Were it specified as definite, one would have:

- (3.1.1.3a) atí yu # Iŋ TÁU  
*'The man is present.'*

Hence, for N to be subject, it must be definite. On the other hand, there are instances of N's which are specified as definite but which are not subjectivised (cases such as these have already been cited in Chapter I but will be repeated here for the sake of the exposition):

- (2.1.1.4)\* páka+lákad na naŋ Pédrú > pákalákad naŋ Pédrú  
*'Pedro exerts himself in walking.'*

(2.1.1.5)\* ka+lákad+lákad na pá? mu? na? Pédrú >  
 ka+lákad+lákad na pá mu? Pédrú  
 'Pedro has just now walked.'

(2.1.1.6)\* ka+ta?ás na na? Pédrú† >  
 katas na? Pédrú †  
 'How tall Pedro is!'

It is not clear why the occurrence of the exertive marker paka-, the immediate completed actual aspect marker ka-, or the exclamative marker ka-, should block subjectivisation. It seems as if the context for subjectivisation blocking is phonological, the occurrence of the sound sequence ka-. This is belied, however, by such counter-examples as:

(2.1.1.7)\* kasín dagúl na ya na? Pédrú # | Suán >  
 kasín dagúl na? Pédrú # | SUÁN  
 'Juan is as big (tall) as Pedro.'

(2.1.1.8) ka+lákad na ya na? Pédrú # | Suán >  
 ka+lákad na? Pédrú # | SUÁN  
 'Juan is in the company of Pedro in walking.'

In these instances, the occurrence of phonological ka- does not block subjectivisation. Hence, the blocking of subjectivisation seems to be rather arbitrary; in the rules to be formulated, the above exceptions must be duly noted.

## 2.1.2. Subjectivised Sentences

### 2.1.2.1. All-New Sentences

In all-new sentences, sentences in which neither V nor any of its accompanying N's is -new, there is actually no choice of subject possible. Subject choice is dictated by the last N to be attached to V, following the ordered replacement rules postulated in section 1.1.6.

State V's may be considered as accompanied by N's in four possible positions (these positions become the basis for linear ordering in a later post-semantic process; at this stage of the derivation, the configuration is still conceived of as non-linear):

	1	2	3	4
		partitive norm goal source location time	patient	beneficiary associate motive experiencer N
V	measure N			

V	1	2	3	4
masantíŋ ya			iŋ balé	
	<i>'The house is pretty.'</i>			
makába yaŋ	aduán kilómetru		iŋ dálan	
	<i>'The road is two kilometres long.'</i>			
pékamasantíŋ yaŋ díli		kariŋ gaŋ ának	i Pédro	
	<i>'Pedro is the best-looking of all among all the children.'</i>			
mátas ya		kaŋ Pédro	i Suán	
	<i>'Juan is taller than Pedro.'</i>			
papuntá ya		kiŋ balé	i Pédro	
	<i>'Pedro is headed for the house.'</i>			
ibát ya		kiŋ balé	i Pédro	
	<i>'Pedro is a-come from the house.'</i>			
atí yu		kiŋ balé	i Pédro	
	<i>'Pedro is present in the house.'</i>			
atín yaŋ			sakít	i Pédro
	<i>'Pedro has a sickness.'</i>			
mákamaté			kaŋ Pédro	iŋ sakít
	<i>'Sickness is motivative of death to Pedro.'</i>			
kalákad neŋ			Pédro	i Suán
	<i>'Juan is in the company of Pedro in walking.'</i>			
bísa yaŋ			pámanán	i Pédro
	<i>'Pedro is in a state of wanting food.'</i>			
másakít ya		kiŋ buntúk	i Pédro	
	<i>'Pedro is sick in the head.' = 'Pedro has a headache.'</i>			

In these sentences, there is no choice of subject; the N in last position is usually subjectivised. The examples likewise show that the most frequent subject N in state V's is the patient N; the patient N is non-subject only in state V's which are specified as motivative, associative, or experiential, and in the exceptions to be described below.

The exceptions arise from particular verb roots, the occurrences of which disturb the unmarked positioning described. Such a disturbance of the unmarked positioning will be accounted for subsequently by extra-position processes which place the N which is eventually to be subjectivised in the last position in a configuration. For example:

(2.1.2.1.1)\* burí? na ya niŋ anák # iŋ dalandán >  
 burí ne niŋ anák # Iŋ DALANDÁN  
*'The orange is liked by the child.'*

where the experiential state verb root *buri?* 'to like [as a permanent state]' has a subjectivised experiencer N (cf. *bísa?* 'in a [temporary] state of wanting'). There are other state V's which are accompanied by a beneficiary N which extrapose the patient N:

- (2.1.2.1.2)\* *kailáŋan na ya niŋ anák # iŋ áutu >*  
*kailáŋan ne niŋ anák # iŋ ÁUTU*  
*'The car is needed by the child.'*

In some types of state V's which are not lexically specified (possessive, intensive, favourite), the accompanying patient N is likewise extraposed:

- (2.1.2.1.3) *kaŋ Pédro ya # iŋ ÁUTU*  
*'The car [belongs] to Pedro.'*
- (2.1.2.1.4) *pará kaŋ Pédro ya # iŋ ÁUTU*  
*'The car is [intended] for Pedro.'*
- (2.1.2.1.5) *pará kaŋ Márkus ya # i PÉDRU*  
*'Pedro is [in a favourite stance] towards*  
*Marcos [as a political candidate].'*

With regards to process V's, the unmarked positioning of accompanying N's may be shown thus (again, following the order of replacement rules postulated in section 1.1.6):

	1	2	3	4
				experiencer
	measure	location	patient	beneficiary
V	N	N	N	N
process				

The following examples will illustrate the positioning of N's accompanying process V's:

V	1	2	3	4
<i>mérágúl yaŋ</i>	<i>aduáŋ pulgáda</i>		<i>iŋ anák</i>	
	<i>'The child grew by two inches.'</i>			
<i>máŋailáŋan yaŋ</i>			<i>péra</i>	<i>iŋ anák</i>
	<i>'The child is needing money.'</i>			
<i>mánákít yaŋ</i>			<i>balé</i>	<i>iŋ anák</i>
	<i>'The child is seeing a house.'</i>			
<i>mánasakít ya</i>		<i>kiŋ buntúk</i>	<i>iŋ anák</i>	
	<i>'The child is hurting in the head.'</i>			

As the examples show, the usual subject of process V's is the accompanying patient N, unless process V is experiential or necessitative. In the latter instances, the non-subject patient is always -definite. If

patient N were definite, the positioning is disturbed: patient N must be extra-posed and eventually subjectivised.

(2.1.2.1.6)\* kailáñan na ya niñ anák # iñ áutu >  
 kai:láñan ne niñ anák # IÑ ÁUTU  
 'The car will be needed by the child.'

(2.1.2.1.7)\* ákákít na ya niñ anák # iñ baláy >  
 ákákít ne niñ anák # IÑ BALÉ  
 'The house is being seen by the child.'

In process V's which are accompanied by a patient N and a measure N, measure N is extra-posed if it is definite:

(2.1.2.1.8) kéragulán na la niñ anák # DIN ADUÁN PULGÁDA  
 x'The two inches were grown by the child.' =  
 'The child grew two inches.'

With regard to action V's, the simple general principle concerning subjectivising the last N to be added to the V configuration applies, except that there are more positions to be accounted for because of the greater number of possible accompanying N's:

	1	2	3	4	5	6
			goal source beneficiary			
	measure	complement	associate	agentive		
V	N	instrument	material	beneficiary	agent	instrument
action		N	N	N	N	<N >
<instrumentative>						
V	1	2	3	4	5	6
ifnákad yañ	aduán	kilómetru			i Pédro	
						'Pedro walked two kilometres.'
gfnawá yañ		lamésa	kiñ dútuñ		i Pédro	
						'Pedro made a table out of the wood.'
gfnámit yañ		tabák			i Pédro	
						'Pedro used a large knife.'
mintá ya			kiñ balé		i Pédro	
						'Pedro went to the house.'
ibát ya			kiñ balé		i Pédro	
						'Pedro came from the house.'
miniyé yañ		digálu	kañ Suán		i Pédro	
						'Pedro gave a gift to Juan.'
mákiyábe ya			kañ Suán		i Pédro	
						'Pedro is joining Juan.'

V	1	2	3	4	5	6
pápagawá yan		balé		kaṅ Suán	i Pédru	
		<i>'Pedro is causing Juan to build a house.'</i>				
páṅlákad nen					Pédru	iṅ bastún
		<i>'The cane is being used by Pedro to walk with.'</i>				

As the examples show, the usual subject of action V's is the agent N; in the rules formulated in section 1.1.6, the agent N is added last to the configuration, unless V is specified as instrumentative, in which case an instrument N is added after agent N has been added. The subjectivisation of the instrument N when V is instrumentative (not instrumental) is thus easily accounted for by means of the ordering of the replacement rules.

Two exceptions were found for the scheme proposed. When action V is both associative and benefactive, the accompanying beneficiary N must be extra-posed and eventually subjectivised:

- (2.1.2.1.9)\* páki+lákad na ya naṅ Pédru # kaṅ Suán # iṅ anák >  
 pákilákad nen Pédru # kaṅ Suán # Iṅ ANÁK  
*'The child is being joined to Juan by Pedro in walking.'*

Since a beneficiary N and an associate N usually occupy the same position (position 3), one of them must be 'edged out'; hence, the beneficiary N is extra-posed.

Moreover, when measure/complement/instrument N's (which usually occupy position 1 and 2) are inflectionally specified as definite, they must be extra-posed and eventually subjectivised:

- (2.1.2.1.10)\* lá+lákad+an na la naṅ Pédru # din aduá? +ṅ kilómetru >  
 lalakáran na laṅ Pédru # DIN ADUAN KILÓMETRU  
*'The two kilometres are being walked by Pedro.'*

- (2.1.2.1.11)\* géwa? na ya niṅ anák # iṅ lamésa >  
 géwa ne niṅ anák # Iṅ LAMÉSA  
*'The table was made by the child.'*

- (2.1.2.1.12)\* g+in+ámit na ya niṅ anák # in tabák >  
 ginámit ne niṅ anák # Iṅ TABÁK  
*'The large knife was used by the child.'*

Process-action V's are accompanied by N's in four possible positions:

	1	2	3	4
V	patient	agentive	agent	instrument
process	N	beneficiary	N	<N >
action				
	<instrumentative>			

The following examples will illustrate the above scheme:

V	1	2	3	4
púpútut yaŋ	dútun		i Pédru	
			<i>'Pedro is cutting wood.'</i>	
pápapútut yaŋ	dútun	kaŋ Suán	i Pédru	
			<i>'Pedro is causing Juan to cut wood.'</i>	
pámútut neŋ	dútun		Pédru	iŋ tabák
			<i>'The large knife is being used by Pedro to cut wood with.'</i>	

When the patient N is definite, however, it must be extra-posed and eventually subjectivised:

(2.1.2.1.13)\* p+In+útut na ya naŋ Pédru # iŋ dútun >  
 pinútut neŋ Pédru # IN DÚTUN

Moreover, when a process-action V is specified as localised and is accompanied by a location N, the patient N must likewise be extra-posed:

(2.1.2.1.3)\* timbúk na ya naŋ Pédru kiŋ sálu? # iŋ anák >  
 timbúk neŋ Pédru kiŋ sálu? # IN ANÁK  
*'The child was hit by Pedro in the chest.'*

In effect, what the preceding discussion has shown is that in all-new sentences, there is really no choice of subject. In sentences with unmarked positioning, the last N to be added to the configuration is subjectivised; in certain verb root types, an N other than the last N to be added is extra-posed and eventually subjectivised. In the latter case, the extra-position is obligatory and not optional.

#### 2.1.2.2. Sentences with -New N's

In sentences which are not all-new and in which V is non-state, there are other extra-position rules which must be stated. Consider the following sentence sequences:

(2.1.2.2.1)

karatánđatán na pá mu niŋ táu	##	pápapútut yaŋ dútun # kaŋ Suán # IN TÁU
new		-new
<i>'The man has just now arrived.'</i>		<i>'The man is causing Juan to cut wood.'</i>

(2.1.2.2.2)

karatánđatán na pá muŋ Suán	##	pápaputútan neŋ dútun niŋ táu # I SUÁN
new		-new
<i>'Juan has just now arrived.'</i>		<i>'Juan is being caused by the man to cut wood.'</i>

(2.1.2.2.3)

karatánđatán na pá mu niŋ dútun	##	pápapútut na niŋ táu# kaŋ Suán # IN DÚTUN
new		-new
<i>'The wood has just now arrived.'</i>		<i>'The wood is being caused by the man to be cut by Pedro.'</i>



patient/complement/instrument/measure N and hence must be subjectivised according to an earlier rule postulated, once again leaving no choice and making the new/-new specification irrelevant. It would be in order to extrapolate and state that when more than two N's are carried over from a previous sentence (provided none of the other extra-position stipulations apply), there is a choice of more than two N's to be extra-posed and eventually subjectivised.

### 2.1.2.3. Extra-position Rules

The stipulations on extra-position may be formulated as post-semantic extra-position rules (post-semantic rules will be marked T#, in keeping with the earlier statement that such post-semantic rules are transformational in character):

(T1') Extra-position Rule I

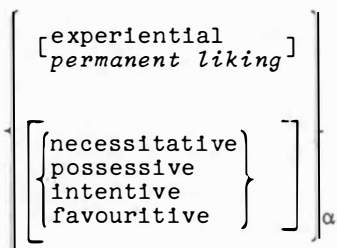
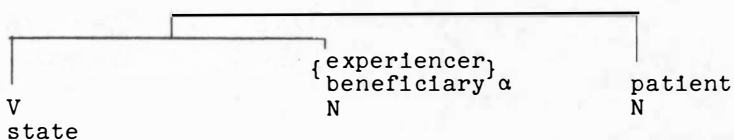
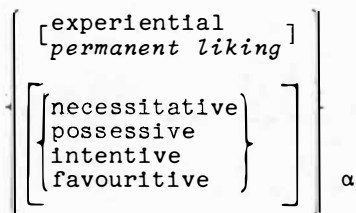
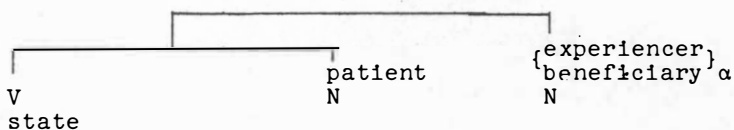

(T2') Extra-position Rule IIa

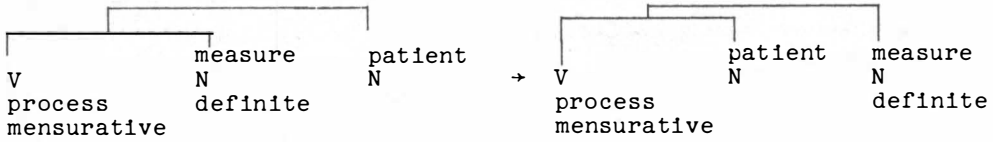

(T3') Extra-position Rule IIb

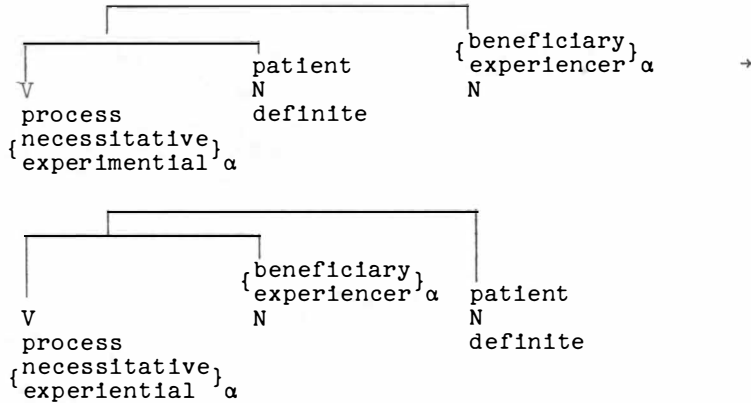

(T4') Extra-position Rule IIIa

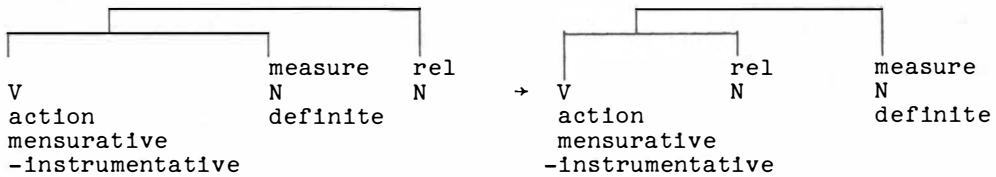

(T5') Extra-position Rule IIIb

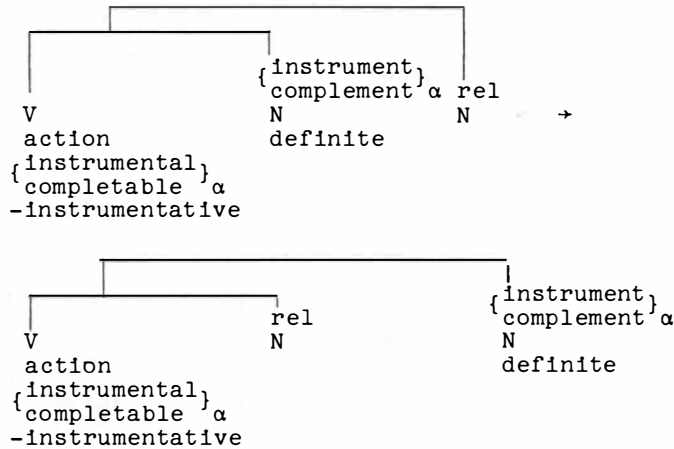

(T6') Extra-position Rule IIIc

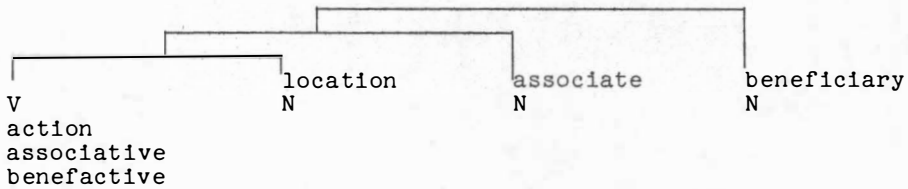
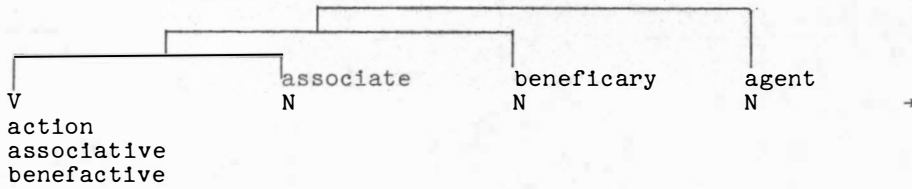

(T7') Extra-position Rule IV

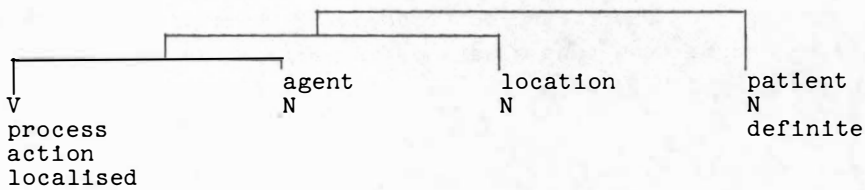
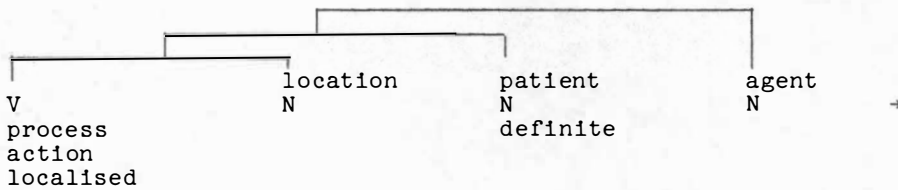

The next two rules apply only if the previous ones have not applied.

(T8') Extra-position Rule Va

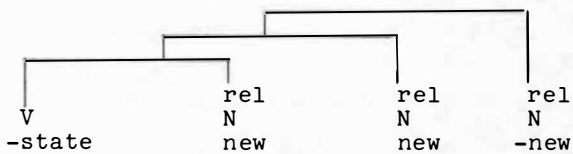
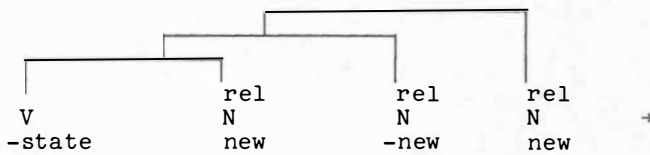

## (T9') Extra-position Rule Vb

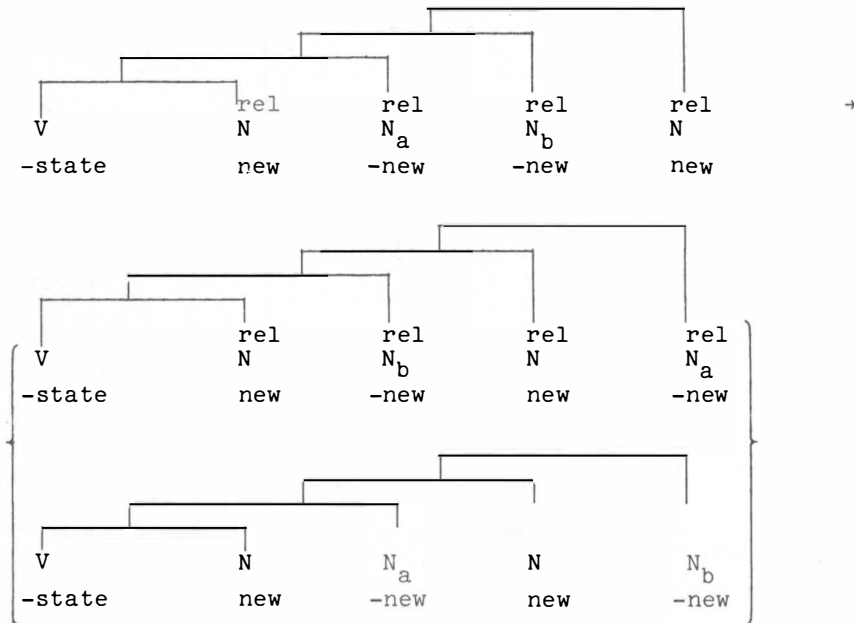

## 2.1.3. Subjectivisation Rule

After the application of the Extra-position Rules (or their non-application, depending on the stated contexts), the outermost N, whether N be specified as new or -new (but always definite), must be specified post-semantically as SUBJECT, with the exceptions earlier noted. The rule may be stated thus:

## (T10') Subjectivisation Rule

rel				
N	##	→→	SUBJECT / V	
definite				{ <ul style="list-style-type: none"> <li>-exertiviser</li> <li>-immediate (aspect)</li> <li>-exclamative</li> </ul> }

where ## is an ad hoc abbreviation for outermost N in the configuration.

## 2.1.4. SUBJECT Incorporation into V

The specification of the outermost N as SUBJECT triggers another post-semantic process, an incorporation process whereby the subject choice is mirrored as an inflectional unit of V; this process accounts for the agreement between the verb root (with its affixes) and the SUBJECT N, a phenomenon which has been noticed among the Philippine languages. For example:

- (2.1.4.1) mágáral yaŋ lisyún # IN ANÁK  
*'The child is studying [some] lesson'.*

(magáral 'to study' lisyún 'lesson', from Spanish lección). In the above sentence, V must be inflectionally specified (by a post-semantic process) as agent subject, which however receives  $\emptyset$  symbolisation. However, were lisyún the subject of the sentence, one would have:

- (2.1.4.1a) págaráIAN ne niŋ anak # IN LISYÚN  
*'The lesson is being studied by the child'.*

where now V is inflectionally specified as complement subject: the symbolisation of the incorporated specification 'complement subject' consists of the sound shift from m to p as well as the suffix -an. The rule may be formulated thus:

(T11') SUBJECT Incorporation Rule

V		rel
root	→	rel subject / N
		SUBJECT

where rel means 'any noun relation' selected as subject.

#### 2.1.5. Subjectivisation in the Scholarly Literature on the Philippine Languages

The preceding account of subjectivisation in Pampangan differs from the view of subjectivisation or 'focus' prevalent in the scholarly literature on the Philippine languages (see, for example, the collection of articles introduced by Wolfenden 1964) not only in nomenclature but also in its view of subject specification in V as reflecting rather than governing subject choice.

SUBJECT specification follows the replacement rules which attach N's to nuclear V. In some well-defined contexts, the resulting configuration is disturbed (and hence, more marked) so that while the usual subject of state and process V's is the accompanying patient N and the usual subject of action and process-action V's is the accompanying agent N, some other N is subjectivised. The outermost N, post-semantically specified as SUBJECT, is the context for a further post-semantic process of incorporation copying subject specification into V; in sentences with unmarked subject choice, this subject specification is symbolised by  $\emptyset$ , but in sentences with marked subject choice, this subject specification is often symbolised by an affix. The mirrored subject choice in V exemplifies a kind of predicate-subject agreement which is overtly marked in V by an affixal symbolisation (the symbolisation can be  $\emptyset$ , of course).

If one adopts this view proposed, subjectivisation is seen to be of the same type as subjectivisation and agreement in most of the languages of the world, for example, in English (the example is based on Fillmore 1968):

The man opened the door with a knife  
 The door was opened by the man with a knife  
 A knife opened the door  
 The door opened with a knife  
 The door opened

The only distinctive characteristic of subjectivisation and agreement phenomena in Pampangan is that while in English, a marked subject choice is often reflected by word order (except for traditional passive sentences, which are marked by both word order and BE-auxiliary as well as past participle), a marked subject choice in Pampangan is reflected by a verbal affix and the determiner *i/in* of the subject choice.

Because V usually precedes the subject N in surface structure, it has often been assumed that V governs subject choice. If one starts with V, it seems that there are almost no constraints, provided one chooses the correct affix and provided one knows what types of N's accompany a particular V root. However, as the rules of the preceding section have shown, there are severe constraints on subject choice, especially with respect to state V's. Only when there are more than one -new N's accompanying V is there really a choice, provided previous extra-position rules have not applied. Moreover, as Chapter IV will show, in responses to questions, subject choice is completely dictated by the question.

The use of the specification new/-new as one relevant context for subjectivisation is novel and confirms Chafe's proposal (1970b) that this semantic distinction is relevant for determining rules of subjectivisation in languages.

Moreover, within the frame of reference adopted here, the use of the term 'focus' is perhaps infelicitous, since 'focus' usually connotes highlighting. What has been termed 'subject' in this study is not particularly highlighted; rather, its usual place in linear structure is at the end of a sentence whereas the place of sentential accent in Pampangan is at the beginning of a sentence. Moreover, after the subject has been copied into V by a further incorporation process (see section 2.4.1), if its referent is clear from the non-linguistic context or if it is -new, it is deletable.

In Bergaño (1916), Castrillo (1965), and Constantino (1965), and in general, in the non-tagmemic scholarly literature on the Philippine languages (including Bloomfield's 1917 Tagalog grammar), the active-passive distinction in verbs traditionally labelled 'transitive' is

made of; in the frame of reference adopted in this study, such transitive verbs are called process-action verbs or completable/instrumental/mensurative action verbs. Thus, Bergaño speaks of the 'tres pasivas', Castrillo describes 'passive action-goal constructions', and Constantino speaks of different types of passives: goal passive, locative passive, and agentive passive. Insofar as an agent N is required in all such verbs and insofar as sentences with agent nouns which are not subjectivised are labelled 'passive', the distinction is valid. Passive sentences would then be all sentences in which an agent N occurs but is not subject. However, this view seems to put undue importance on an agent N accompanying V. It is quite clear that different V's take different N's, and that any  $N^{rel}$  is of equal importance, whether it be  $N^{agent}$  or not. It would seem then that the active/passive dichotomy is insufficient, and as Pike (1963) has observed, the possibility of subjectivising (focusing on) different N's should lead us to postulate not two voices but as many voices as there are N types accompanying a V, insofar as each N is subjectivisable. Hence, it would be more proper to speak of an active voice (where agent N is subject), a passive voice (where patient N is subject), a benefactive voice (where beneficiary N is subject), a locative voice (where location N is subject), and so forth.

## 2.2. SYNCRETISATION

Once the outermost N has been post-semantically marked SUBJECT in a semantic configuration, all other accompanying N's must be specified as either OBLIQUE or left unmarked (-OBLIQUE). Eventually, subject N's are marked by the determiner  $i/i\eta$ , oblique N's by the determiner  $ka\eta/ki\eta$  if they are definite, -oblique N's by the determiner  $na\eta/ni\eta$  if they are definite. If -subject N's are -definite, they have a  $\emptyset$  determiner; subject N's are, of course, always definite. Which N relations must be post-semantically marked OBLIQUE is shown by the chart below and exemplified in the following sentences:

	agent experiencer instrument complement measure patient	agentive beneficiary beneficiary motive norm associate partitive material source goal location time	
V	N -SUBJECT -OBLIQUE	N -SUBJECT +OBLIQUE	N SUBJECT

Each of the sentences below exemplifies one <sup>rel</sup>N :  
-SUBJECT

- (2.2.1)\* gagáwan na ya niŋ anák # iŋ sílya >  
gagáwan ne NIŋ ANÁK # iŋ sílya  
agent  
'The chair is being made by the child.'
- (2.2.2) ákákít ne NIŋ ANÁK # iŋ balé  
experiencer  
'The house is being seen by the child.'
- (2.2.3) gágámit yaŋ SANDÚK # iŋ anák  
instrument  
'The child is using [a] wooden spoon.'
- (2.2.4) gágawá yaŋ SÍLYA # iŋ anák  
complement  
'The child is making a chair.'
- (2.2.5) makába yaŋ ADUÁN KILÓMETRU # iŋ dálan  
measure  
'The road is two kilometres long.'
- (2.2.6) púpútut yaŋ DUTÚŋ # iŋ anák  
patient  
'The child is cutting wood.'
- (2.2.7) pápagawá yaŋ sílya # KIŋ TÁU # iŋ anák  
agentive beneficiary  
'The child is causing the man to make a chair.'
- (2.2.8) babiyé yaŋ digálu # KIŋ ANÁK # i Pédro  
beneficiary  
'Pedro is giving [a] gift to the child.'
- (2.2.9) KIŋ PISTÍ # iŋ páŋamaté da diŋ manúk  
motive  
'The death of the chickens is due to pestilence.'

- (2.2.10) maragúl ya # KIN ANÁK # i Pédrú  
norm  
'Pedro is taller (lit. bigger) than the child.'
- (2.2.11) mákilákad ya # KIN TÁU # i Pédrú  
associate  
'Pedro is joining the man in walking.'
- (2.2.12) pékamaragúl yaṅ díli # KARIN GAN ANÁK # i Pédrú  
partitive  
'Pedro is the biggest of all among all the children.'
- (2.2.13) gágawá yaṅ sílya # KIN DUTÚN # in táu  
material  
'The man is making a chair out of the wood.'
- (2.2.14) máníbát ya # KIN BALÉ # in anák  
source  
'The child is coming from the house.'
- (2.2.15) púpuntá ya # KIN BALÉ # in anák  
goal  
'The child is going to the house.'
- (2.2.16) atí yu # KIN BALÉ # in anák  
location  
'The child is present in the house.'
- (2.2.17) KIN LUNIS # in pistá  
time  
'The fiesta takes place on Mondays.'

Sentences (2.2.3) to (2.2.6) exemplify -SUBJECT -OBLIQUE -definite N's, marked by  $\emptyset$  determiner. OBLIQUE-marked N's are usually definite. However, in the sentence:

- (2.2.218) antí yaṅ bábi? # i Pédrú  
'Pedro is like a pig.'

the norm N, which is usually OBLIQUE, is likewise -definite, and receives  $\emptyset$  determiner. An easy way to account for this is to make OBLIQUE specification dependent on prior definite specification as a context.

There are irregularities to the oblique/-oblique specifications described above; these will be accounted for by other post-semantic processes involving oblique/-oblique shifts. The rule may be formulated thus:

## (T12') Syncretisation Rule

agentive beneficiary beneficiary motive norm associate partitive material source goal location time	→→	OBLIQUE
N		
definite		
-SUBJECT		

The term 'syncretisation' has been used in labelling the rule, since the post-semantic process of specifying a subset of the N relations as oblique and the rest as -oblique amounts to a traditional syncretisation of 'cases'. In Pampangan, the underlying semantic relations between V and N are reduced to three surface 'cases': nominative (i/iŋ), dative (kaŋ/kiŋ), and genitive (naŋ/niŋ). Lopez (1941), in his study of Tagalog, posits a 'nominative case', a 'locative case', and an 'attributive case', corresponding to the three cases posited above. If one considers case as a surface category rather than as a deep category, in the frame of reference in this study, as a post-semantic specification rather than as a semantic relation, then Lopez's threefold division would be valid likewise for Pampangan (and most likely, for the other Philippine languages as well). It would be futile, however, to attempt to discover a Grundbedeutung or even a Gesamtbedeutung for these surface structure cases, since, for example, the nominative case has a potential of seventeen Bedeutungen and perhaps even more should it be deemed necessary in the future to posit more N relations.

## 2.3. OBLIQUE/-OBLIQUE SPECIFICATION SHIFTS

2.3.1. Shift: N to N  
OBLIQUE -OBLIQUE

Consider the sentences:

- (2.3.1.1) úli na niŋ pistí # iŋ sakít  
'The sickness is due to the pestilence.'
- (2.3.1.2) kailáŋan neŋ Pédrú # iŋ áutu  
'The car is needed by Pedro.'
- (2.3.1.3) kasíŋ dagúl neŋ Pédrú # i Suán  
'Juan is as big as Pedro.'

(2.3.1.4) kalúpa neŋ Pédro # I Suán

'Juan looks like (lit. of the same face as) Pedro.'

where the motive N, the beneficiary N, the norm N, ordinarily specified as OBLIQUE, are -OBLIQUE, It seems that the shift is conditioned by particular verb roots or derivational affixes of verb roots. The rule may be formulated thus:

(T13') OBLIQUE to -OBLIQUE Shift Rule I

$$\begin{array}{ccc}
 \left\{ \begin{array}{l} \text{motive} \\ \text{beneficiary} \\ \text{norm} \end{array} \right\} & \rightarrow & \left\{ \begin{array}{l} \text{motive} \\ \text{beneficiary} \\ \text{norm} \end{array} \right\} \alpha \\
 \text{N} & & \text{N} \quad / \quad \text{V} \\
 \text{OBLIQUE} & & \text{-OBLIQUE} \quad \left[ \begin{array}{l} \text{state} \\ \left[ \begin{array}{l} \text{due to} \\ \text{needing} \end{array} \right] \\ \left[ \left[ \begin{array}{l} \text{equatative} \\ \text{similaritive} \end{array} \right] \right] \end{array} \right] \alpha
 \end{array}$$

There are yet other instances of OBLIQUE to -OBLIQUE shift. Consider the following sentences:

(2.3.1.5) masantín ya # Iŋ piyálúnan na niŋ anák  
'The toy of the child is pretty.'

(2.3.1.6) malatf ya # Iŋ turnilyú na niŋ piyálúnan  
'The screw of the toy is small.'

(2.3.1.7) maragúl ya # iŋ kilúb na niŋ balé  
'The inside of the house is big.'

In sentence (2.3.1.5), anák is a beneficiary N; in sentence (2.3.1.6) piyálúnan is a partitive N; and in sentence (2.3.1.7) balé is a partitive N. The semantic structures of the first two sentences will be discussed in Chapter III; the third sentence has already been accounted for by the rules of Chapter I (see section 1.1.6). What is relevant at this point is that the beneficiary N and the partitive N's, which are ordinarily OBLIQUE, are -OBLIQUE in  $\overline{\text{N}} \text{N}$  surface sub-structures. The rule may be formulated thus:

(T14') OBLIQUE to -OBLIQUE Shift Rule II

$$\begin{array}{ccc}
 \left\{ \begin{array}{l} \text{beneficiary} \\ \text{partitive} \end{array} \right\} & \rightarrow & \left\{ \begin{array}{l} \text{beneficiary} \\ \text{partitive} \end{array} \right\} \quad \left[ \begin{array}{l} \text{beneficiary} \\ \text{partitive} \end{array} \right] \\
 \text{N} & & \text{N} \quad \text{N} \\
 \text{OBLIQUE} & & \text{-OBLIQUE}
 \end{array}$$

2.3.2. Shift: N to N  
-OBLIQUE OBLIQUE

Consider the following sentences:

- (2.3.2.1)\* di+dínan na ya+η péra naη Pédrú # iη anák >  
dirínan neη péraη Pédrú # iη anák  
'The child is being given money by Pedro.'

The above sentence is perfectly regular, with the non-subject agent N marked by naη. However, consider the sentence:

- (2.3.2.2) mirirínan yaη péra # kaη Pédrú # iη anák  
x'The child is being able to be given money by Pedro.' =  
'Pedro is getting to give money to the child.'

As a result of the derivational lexical unit added to dínan, symbolised by mi-, the non-subject agent N is now marked by oblique kaη. It is difficult to label the semantic unit symbolised by mi-; merely as a convenience, it will be labelled 'non-active abilitativiser' and is best translated as 'get to'. Again, consider the sentence:

- (2.3.2.3) mákamaté # kaη Pédrú # iη sakít  
'The sickness is motivative of death to Pedro.'

where now the patient N, when non-subject normally marked by naη, is marked by oblique kaη, in the presence of motivativiser symbolised by maka-. The rule may be formulated thus:

(T15') -OBLIQUE to OBLIQUE Shift Rule

{agent patient}		{agent patient}α			
N definite	→	N definite	/	V	
-OBLIQUE		OBLIQUE			$\left. \begin{array}{l} \text{action} \\ \text{non-active abilitativiser} \\ \text{state} \\ \text{motivativiser} \end{array} \right\} \alpha$

## 2.4. INCORPORATIONS

### 2.4.1. Incorporation of Specifications of N into V. SUBJECT

Consider the sentences:

- (2.4.1.1) matápaη YA # | Pédrú 'Pedro is brave.'  
(2.4.1.2) sísikán YA # | Pédrú 'Pedro is growing stronger.'  
(2.4.1.3) gágápaη YA # | Pédrú 'Pedro is crawling.'

Some specifications of SUBJECT N are copied into the verb phrase, symbolised by the particle *ya*, translatable as 'he, she, it'. An incorporation process must be posited, therefore, copying features of the SUBJECT N into V, the incorporated copier eventually symbolised as an unbound formative. If SUBJECT N is plural, the copier must likewise be plural:

- (2.4.1.4) *matápaŋ YA # iŋ anák* 'The child is brave.'  
*matápaŋ LA # diŋ ának* 'The children are brave.'

Moreover, if the SUBJECT N is inflectionally specified as 'total', 'total' may be part of the copier matrix:

- (2.4.1.5) *matápaŋ LA # diŋ gaŋ ának*  
*matápaŋ LANJAN # diŋ gaŋ ának*  
 'All the children are brave.'

Not all SUBJECT N's are incorporated, however:

- (2.4.1.6) *máyap # iŋ bálak mu*  
 (2.4.1.7) *mabáyat # iŋ burf mu* 'What you want is difficult  
 (lit. heavy).'  
*masantfŋ # iŋ dapát mu* 'What you are doing (or did)  
 is fine.'

The SUBJECT N's in the above sentences are abstract. In (2.4.1.8), if the referent of N is a particular artifact and not just 'what has been done', the sentence would be:

- (2.4.1.8a) *masantfŋ YA # iŋ dépat mu*  
 'What you did (that is, the artifact) is fine.'

It is not only abstract N's which are not copied:

- (2.4.1.9) *búbusúk # iŋ urán*  
 'The rain is pouring.'  
 (2.4.1.10) *malulútu? # iŋ pámaŋán*  
 'The food is getting cooked.'  
 (2.4.1.11) *ákakamaté na niŋ anák # iŋ lagnát*  
 'Fever is causing the child to die.'

The N's in the above sentences are concrete (-abstract), but they are likewise -count.

Since all N's which are subjectivised must be definite, the inflectional unit definite need not be indicated in the rule which will be formulated. To keep the rule as general as possible, the inflectional unit 'total' will be stipulated as obligatorily copied and then by a later post-semantic deletion process, optionally deletable. The subject

incorporation rule may be formulated thus (the necessity for the explicit inclusion of the lexical root in the rule will be clarified below):

(T16') SUBJECT Incorporation Rule I

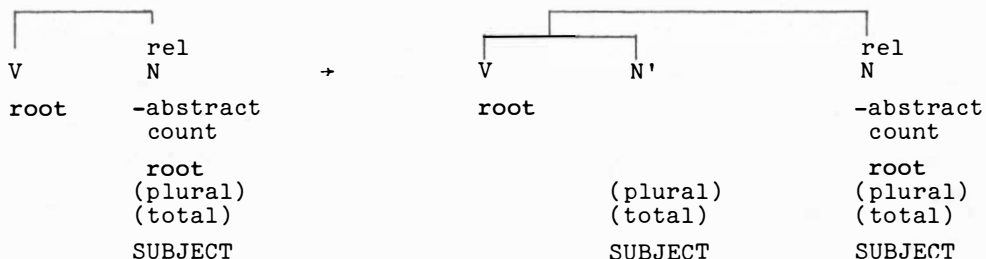

Note that it is the inflectional units which are incorporated into V as N' and not the selectional or lexical units.

In Chapter I, several examples were given of state V's which were not specified by a lexical unit:

- (2.4.1.12) kaṅ Pédro ya # iṅ balé  
'The house [belongs] to Pedro.'
- (2.4.1.13) pará kiṅ anák ya # iṅ maníka?  
'The doll [is intended] for the child.'
- (2.4.1.14) pará kaṅ Márkus ya # i Pédro  
'Pedro is [in a favouritive stance] towards Marcos [as a political candidate].'
- (2.4.1.15) kiṅ balé # iṅ taú  
'The banquet [is taking place] in the house.'
- (2.4.1.16) kéṅ lúnis # iṅ taú?  
'The banquet [will take place] on Monday.'
- (2.4.1.17) kiṅ balé ya # iṅ pasbúl  
'The door [is part] of the house.'

The V's of the preceding sentences are V's without lexical specifications: V . Now, without a lexical root, the copier

$$\left. \begin{array}{l} \text{state} \\ \text{possessive} \\ \text{intensive} \\ \text{favouritive} \\ \text{locative} \\ \text{temporal} \\ \text{partitive} \end{array} \right\}$$

(no lexical root)

(N') has no 'carrier' to attach to in surface structure. In the case of sentence (2.4.1.15) and (2.4.1.16), the question of incorporation

does not arise, since tau? 'banquet, merry-making' is selectionally specified as abstract (an event, not an object) in Pampangan and hence is not copied. In general, it seems that only abstract N's may occur with non-lexically specified locative or temporal state V's. If a -abstract count N is to be located in space, a presential state V is used instead:

(2.4.1.18) atf yu # kiŋ balé # lŋ bóla  
'The ball is present in the house.'

Hence, to account for the incorporation process for state V's which are not lexically specified, only the following sub-types need be considered: possessive, intentive, favouritive, and partitive. In these V's, the copier is incorporated not into V, which is eventually deleted, but into the accompanying beneficiary N or partitive N branch. A second SUBJECT Incorporation Rule will therefore be necessary:

(T17') SUBJECT Incorporation Rule II

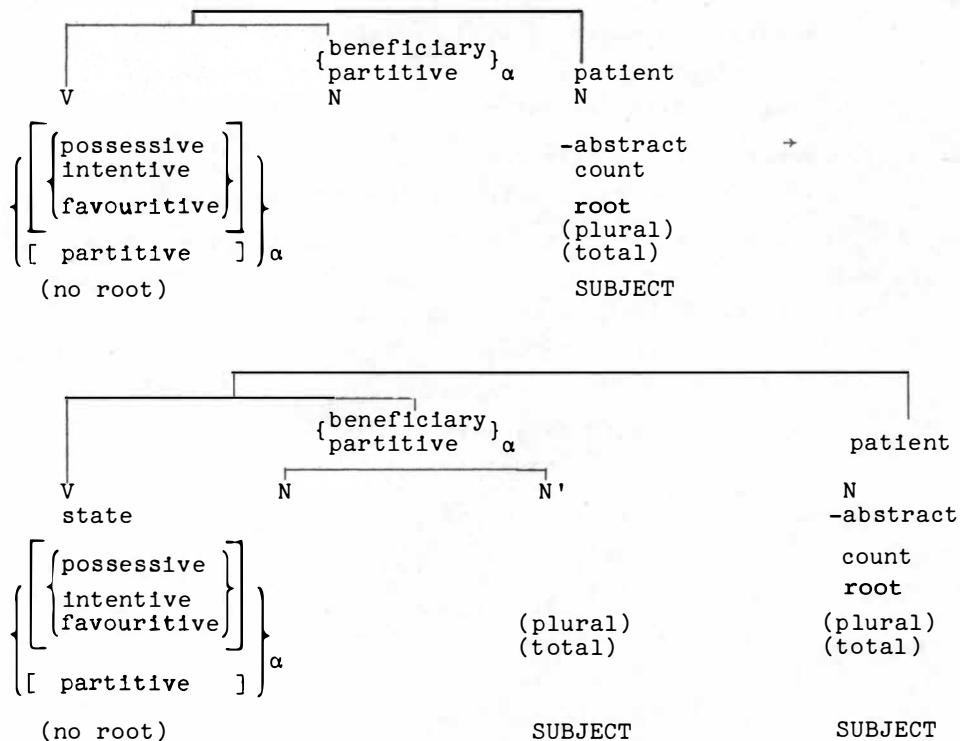

In most of the examples given thus far, the SUBJECT copier is symbolised by ya. In sentence (2.4.1.18), however, the symbolisation for the copier is yu. Variant symbolisations of the copier occur with the state presential V atf:

- (2.4.1.19) atf YU # i Pédro  
'Pedro is present.'
- (2.4.1.19a) atf LU # di Pédro  
'Pedro and [his] companions are present.'
- (2.4.1.19b) atf LUÑAN # di Pédro  
'Pedro and all [his] companions are present.'

The third sentence is interesting insofar as 'total' is post-semantically deleted from SUBJECT N but retained in SUBJECT N'.

#### 2.4.2. Incorporation of Specificiations of N into V

-SUBJECT  
-OBLIQUE

It is not only the SUBJECT N which is copied into V. Consider the sentences:

- (2.4.2.1) burf NA niñ anák # iñ pámaglakbé  
'Travel is liked by the child.'
- (2.4.2.2) kararagulán NA niñ anák # iñ imálan  
x 'The cloth(es) are being grown out of by the child.' =  
'The child is growing out of his clothes.'
- (2.4.2.3) kakanán NA niñ anák # iñ pámanán  
'The food is being eaten by the child.'

In the examples cited, the non-subject non-oblique N, marked by nañ/niñ, is copied and incorporated into V as na. Since the subject in each of the sentences is either abstract or -count, it is not copied into V.

Not every non-subject and non-oblique N is copied into V, however, as the following sentences show:

- (2.4.2.4) bísá yañ pámanán # iñ anák  
'The child wants [some] food.'
- (2.4.2.5) gágámit yañ tabák # iñ anák  
'The child is using [a] knife.'
- (2.4.2.6) lálákad yañ aduán kilómetru # iñ anák  
'The child is walking two kilometres.'
- (2.4.2.7) gágawá yañ sílya # iñ anák  
'The child is making [a] chair.'

In the sentences cited, the non-subject and non-oblique N is likewise -definite; hence, the determiner has  $\emptyset$  symbolisation. It is evident then that the inflectional unit 'definite' must be included as a context for the incorporation rule. Moreover, if N is plural, N' must likewise be plural:

- (2.4.2.8) kakanán NA niḡ anák # iḡ pámanán  
 kakanán DA diḡ anak # iḡ pámanán  
 'The food is being eaten by the child.'  
 'The food is being eaten by the children.'

The determiner for non-subject and non-oblique plural agent 'child' is diḡ and although homophonous with the plural subject determiner niḡ must be distinguished from it. The non-subject and non-oblique plural copier is symbolised by da. Moreover, non-subject and non-oblique N may be inflectionally specified as 'total' and copied accordingly.

- (2.4.2.9) kakanán DAḂÁN # diḡ gaḡ anak # iḡ pámanán  
 'The food is being eaten by all the children.'

The examples cited thus far have copied SUBJECT N or -SUBJECT -OBLIQUE N, not both. It is possible to copy both into V:

- (2.4.1.10)\*ka+kantán NA YA niḡ anák # iḡ manúk >  
 kakanán NE niḡ anák # iḡ manúk  
 'The chicken is being eaten by the child.'

- (2.4.2.11) kakanán NA LA niḡ anák # diḡ manúk ~  
 kakanán NO niḡ anák # diḡ manúk  
 'The chickens are being eaten by the child.'

- (2.4.2.12) kakanán NA LANAN niḡ anák # diḡ gaḡ manúk ~  
 kakanán NÓḂAN niḡ anák # diḡ gaḡ manúk  
 'All the chickens are being eaten by the child.'

- (2.4.2.13)\*ka+kantán DA YA diḡ anak # iḡ manúk >  
 kakanán DE diḡ anak # iḡ manúk  
 'The chicken is being eaten by the children.'

- (2.4.2.14)\*ka+kantán DAḂAN YA diḡ gaḡ anak # iḡ manúk >  
 kakanán DÉḂAN diḡ gaḡ anak # iḡ manúk  
 'The chicken is being eaten by the children.'

- (2.4.2.16)\*ka+kantán DA+ḂAN LA+ḂAN diḡ gaḡ anak # diḡ gaḡ manúk >  
 kakanán DALANÁN diḡ gaḡ anak # diḡ gaḡ manúk ~  
 kakanán DÓḂAN diḡ gaḡ anak # diḡ gaḡ manúk  
 'All the chickens are being eaten by all the children.'

It was necessary to state the various possibilities in full to show the regularity of patterning of the N' N' combinations, called by Castrillo 'portmanteau pronouns'; in failing to note explicitly the basic sameness of the variants, Castrillo has unduly enlarged the inventory of such 'portmanteau pronouns'.

The metathesis (syllable) shown in (2.4.2.14) is sporadic and not regular: \*da+ḡan+yá > \*dayáḡan > déḡan. The obligatory deletion of

the semantic unit 'total' in the non-oblique copier of (2.4.2.16) may be accounted for by an obligatory deletion rule to be stated in section 2.4.2.5. It is difficult to find 'phonologically natural' reasons for the optional phonological rule exemplified by ?na la > no and ?da la > do. It would be better perhaps to consider na la/no and da la/do as variants in the symbolisation of the N' N' combinations.

It is not clear whether a non-subject and non-oblique definite N must likewise be selectionally specified as non-abstract and count to be copied. Usually, abstract N's and -count N's, if definite, are subject N's and not copied. In sentences such as

(2.4.2.17) péte NE niḡ lagnát # i Pédrú  
'Pedro was killed by the fever.'

(2.4.2.18) péte NE niḡ pámagáral # i Pédrú  
'Pedro was killed by [too much] study.'

lagnát 'fever' is inherently -count and pámagáral 'studying' is inherently abstract; yet both are copied into V as na. It seems, however, that in the above sentences, both N's have undergone a derivational process in effect personifying them, for one also says:

(2.4.2.19) péte NE niḡ tulisán # i Pédrú  
'Pedro was killed by the robber.'

This point deserves further investigation. In the statement of the incorporation rule, tentatively, no selectional units will be used as contexts for incorporation: in other words, the rule states that all non-subject and non-oblique definite N's are copied into V:

(T18') -SUBJECT -OBLIQUE N Incorporation Rule

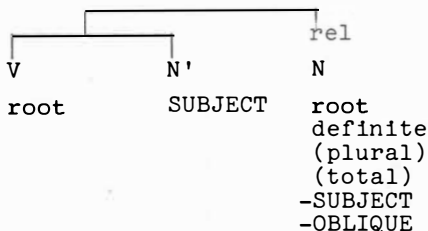

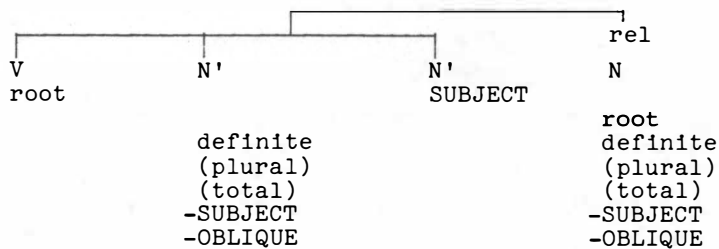

#### 2.4.3. Incorporation of Specifications of N into V OBLIQUE

In general, oblique-marked N's are not copied and incorporated into V, with one exception:

- (2.4.3.1) pékamaragúl yaŋ DÍLI kariŋ gaŋ ának # i Pédro  
'Pedro is the biggest of all among all the children.'

díli is an invariant form and occurs only with partitive N's in which a state V is inflected as superlative. The rule may be formulated thus:

(T19') OBLIQUE N Incorporation Rule

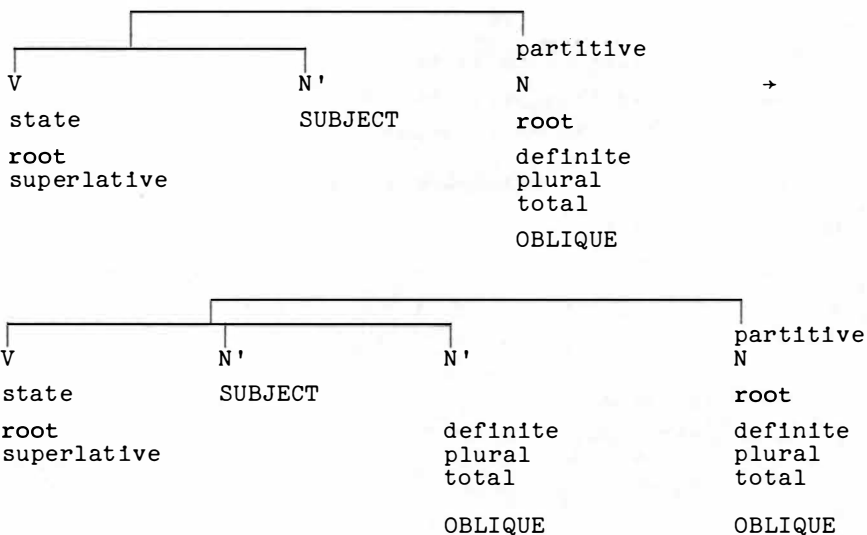

#### 2.4.4. Incorporation of Specifications of N into N -SUBJECT -OBLIQUE

It has shown in section 2.3.1. that in N N sub-structures in which the second N is beneficiary or partitive, OBLIQUE beneficiary or partitive N becomes -OBLIQUE by a Shift Rule. In turn, the resulting -SUBJECT -OBLIQUE N must undergo an incorporation process:

(2.4.4.1) masantíŋ ya # iŋ balé NA niŋ anák  
'The house of the child is pretty.'

(2.4.4.2) malatf ya # iŋ turnllyú NA niŋ piyálúŋan  
'The screw [which is part] of the toy is small.'

If the beneficiary or partitive N is plural (and total), the specifications plural (and total) must likewise be incorporated into the first N:

(2.4.4.3) masantíŋ ya # iŋ balé DA diŋ ának  
'The house of the children is pretty.'

(2.4.4.4) masantíŋ ya # iŋ balé DANÁN diŋ gaŋ ának  
'The house of all the children is pretty.'

Sentence (2.4.4.1) has the variant:

(2.4.4.1') masantíŋ ya # iŋ balé niŋ anák

Since sentences such as (2.4.4.3) in which the N' is plural do not allow a similar deletion, it will perhaps not be necessary to formulate a deletion rule for (2.4.4.1') but attribute the optional loss of na to phonological haplology. The phonological rather than semantic reason for the deletion becomes more evident when the beneficiary N is unique:

(2.4.4.1a)\*masantíŋ ya # iŋ baláy NA naŋ Pédro >  
masantíŋ ya # iŋ balé NAŋ Pédro  
'The house of Pedro is pretty.'

The incorporation rule may be formulated thus:

(T20') -SUBJECT -OBLIQUE N Incorporation Rule II

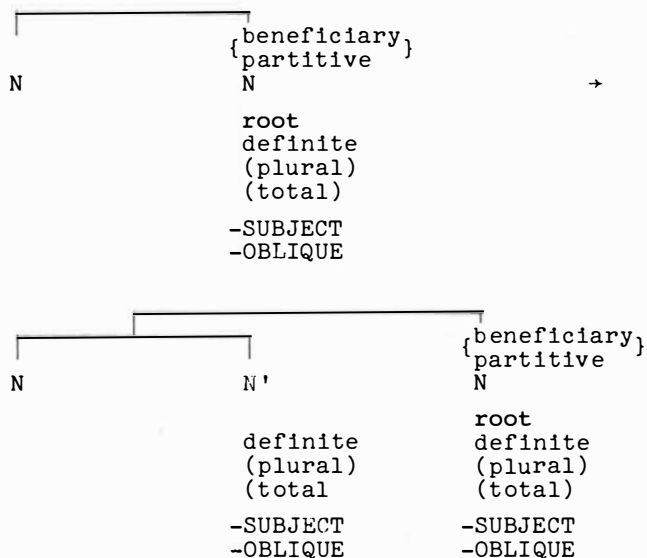

#### 2.4.5. Optional Incorporation of Plural into V -action

Consider the sentence pairs:

(2.4.5.1) malagú la # diŋ dálága ~  
maŋalagú la # diŋ dálága  
'The young women are beautiful.'

(2.4.5.2) mamamaté la # diŋ manúk ~  
maŋamate la # diŋ manúk  
'The chickens are dying.'

In both examples, the infix -ŋa- is an optional plural marker incorporated into V and mirrors the plural inflection of SUBJECT N. It seems, however, that -ŋa- symbolises plurality only with non-action V's. In action V's, -ŋa-, as was shown in Chapter I (see section 1.1.8.2), symbolises repetition of action rather than plurality of subject:

(2.4.5.3) lálákad ya # i Pédrú  
'Pedro is walking.'  
máŋlákad ya # i Pédrú  
'Pedro walks repeatedly.' =  
'Pedro walks to many places.'

Note that -ŋa- as a symbolisation for repetition occurs with a non-plural subject N, whereas -ŋa- as a symbolisation for plurality in non-action V's may occur only with a plural subject N. Since -ŋa- is an infix, it needs a 'carrier', a prefix to hang on to; hence, mag- in (2.4.5.3): \*mag+ŋa > maŋ-. The common symbolisation of plurality and repetition attests to a semantic relation. More than likely, the semantic units 'plural' and 'repetitive' have diverged from a common unit. An interesting instance of ambivalence is manifest in:

(2.4.5.4) maŋapatalúras la # diŋ ának

(from mipatalúras 'to slip unintentionally' (lit. slip + unintentionaliser)). The sentence may mean:

*'The children are slipping unintentionally.'*

in which case -ŋa- symbolises a plural marker from plural SUBJECT patient N. Or it may mean:

*'The children are slipping unintentionally repeatedly.'*

where now -ŋa- symbolises 'repetitive' and perhaps simultaneously, 'plural', when it occurs with non-action V's. The example presents an interesting instance of language in change. The relevant rule may be formulated thus:

## (T21') Plural Incorporation Rule

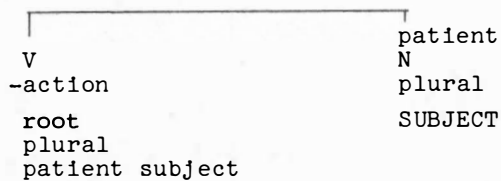
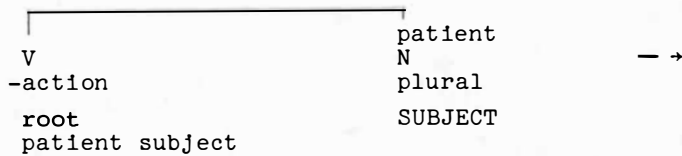

## 2.4.6. Incorporation of N into V

-SUBJECT  
-OBLIQUE

Consider the sentence:

- (2.4.6.1)\* má+maŋ+kán ya # ságin # | Pédrú >  
 mámaŋán ya +ŋ ságin # | Pédrú >  
 mámaŋán yaŋ ságin # | Pédrú  
 'Pedro is eating [a] banana.'

where the patient N (-SUBJECT -OBLIQUE -definite) has been linked to V (and copier N') by means of the ligature -ŋ. Even if the non-subject and non-oblique N is definite, linking still occurs:

- (2.4.6.2)\* ka+kan+tán na ya # naŋ Pédrú # iŋ ságin >  
 kakanán neŋ Pédrú # iŋ ságin  
 'The banana is being eaten by Pedro.'

The phonological synthesis \*na+ya+naŋ > neŋ does not occur when the non-subject and non-oblique N is non-unique, but the absence of pause still attests to incorporation, phonologically manifest as boundary deletion:

- (2.4.6.3)\* ka+kan+tán na ya # niŋ anák # iŋ ságin >  
 kakanán ne niŋ anák # iŋ ságin  
 'The banana is being eaten by the child.'

It should be noted that when there is more than one non-subject non-oblique N (in certain maximally specified V's), even the second non-subject and non-oblique N is incorporated into V:

- (2.4.6.4)\* ga+gawá? ya # lamésa # kiŋ dútuŋ # | Pédrú >  
 gágawá? yaŋ lamésa # kiŋ dútuŋ # | Pédrú  
 'Pedro is making [a] table out of the wood.'

(2.4.6.5)\* ga+gawa?+tan na ya # lamésa # naŋ Pédru # iŋ dútuŋ >  
 gagáwan neŋ lamésaŋ Pédru # iŋ dútuŋ  
 'The wood is being made into [a] table by Pedro.'

Or:

(2.4.6.5a)\* ga+gawa?+tan na ya # lamésa # niŋ anák # iŋ dútuŋ >  
 gagáwan neŋ lamésa niŋ anák # iŋ dútuŋ  
 'The wood is being made into [a] table by the child.'

The occurrence of sentences such as (2.4.6.5) and (2.4.6.5a) where there are two non-subject and non-oblique N's seems to occur only with action V's with more than two accompanying N's in which the agent N is non-subject; in such instances, the other non-subject and non-oblique N is always -definite (and therefore without a determiner).

The incorporation of non-subject and non-oblique N's into V is analogous to the closer relation in English between the verb and its direct object on the one hand and the subject on the other hand. In Pampangan, the integration in the verb phrase resulting from such incorporation is so close that the two non-subject and non-oblique N's may even exchange positions in surface structure:

(2.4.6.5') gagáwan neŋ Pédruŋ lamésa # iŋ dútuŋ  
 'The wood is being made by Pedro into [a] table.'

The incorporation rule may be formulated thus:

(T22') -SUBJECT -OBLIQUE N Incorporation Rule

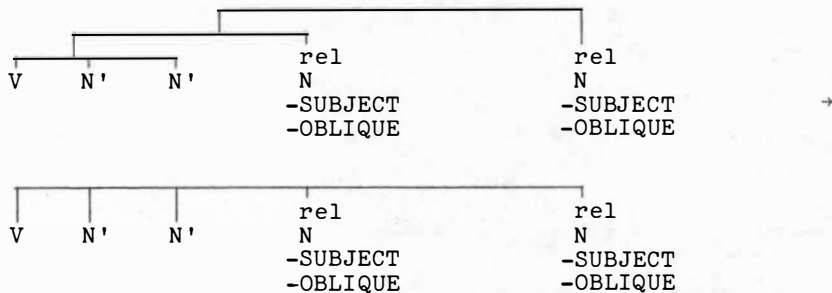

The output of (T22') may undergo the optional transposition:

(T23') -SUBJECT -OBLIQUE N Transposition Rule

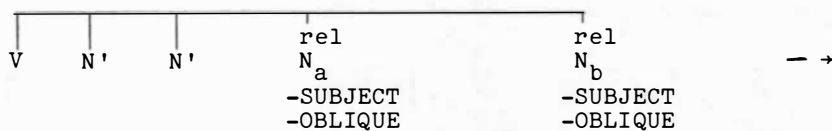

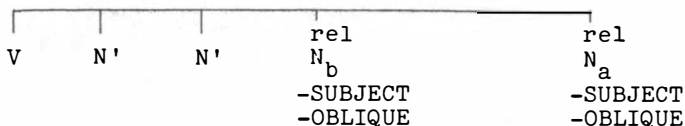

#### 2.4.7. Status of # Boundary Marker in Pampangan

By now, from the examples given, it should be clear that a special status is given to the # boundary marker in Pampangan, a marker earlier called a 'phrase boundary'. In other words, the phrase has structural importance in Pampangan as an operational concept for accounting for certain grammatical phenomena. The # boundary marker, phonologically interpretable as pause, is correlated to a branch in the semantic configuration, either a V (with its incorporations) or an N (with its determiner and its incorporations).

There is thus need in Pampangan to postulate as a significant and functional unit an element larger than a word but smaller than a sentence. Without such a unit, it will be difficult to adequately account for the occurrence of ligature a/-ŋ, which functions to link not words (indicated by spaces) but phrases (indicated by #) where # has been deleted. Hence, the ligature is more than just a phonological additive for 'ease of articulation' but is a marker for the deletion of #, a marker for incorporation.

Consider the two sentences:

(2.4.7.1) masantíŋ ya # iŋ ígu?  
'The rattan basket is pretty.'

(2.4.7.2) masantíŋ ya+ŋ ígu? # iyán  
'That is a pretty rattan basket.'

In the first sentence, there is no ligature to link ya and iŋ because the two formatives belong to different branches:

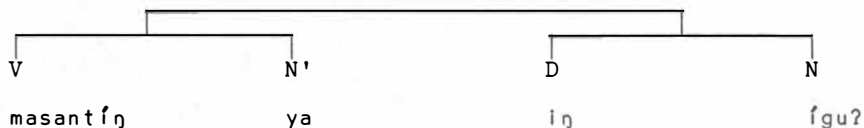

In the second sentence, however, where 'pretty rattan basket' is an embedded V N structure, in surface structure, the configuration is:

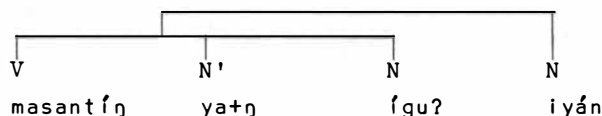

In the second sentence, there is a ligature between *ya* and *igu?* precisely because *igu?* is incorporated within the  $\overline{V \quad N' \quad N}$  branch.

Confronted then with a surface structure, the absence of # attests to prior incorporation:

- (2.4.7.3) *gagáwan neŋ lamesaŋ Pédru # iŋ dútuŋ*  
*'The wood is being made into [a] table by Pedro.'*

which may be represented thus:

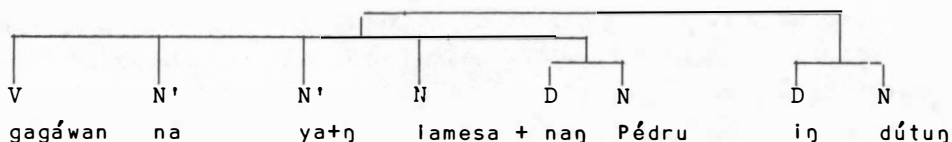

Within a branch, for example,  $\overline{V \quad N' \quad N'}$ , one must distinguish between words (indicated by spaces) and affixes (where explicitation is necessary, indicated by +). The unbound status of the copiers, particles or clitics (in subsequent chapters, more of these clitics incorporated within V will be discussed), makes it necessary to distinguish them from the bound affixes. For example:

- (2.4.7.1) *ma+santfŋ ya # iŋ ígu?*  
*'The rattan basket is pretty.'*

Now the clitic *ya* may be transposed, as in negative sentences:

- (2.4.7.1a) *é ya ma+santfŋ # iŋ ígu?*  
*'The rattan basket is not pretty.'*

Moreover, between determiner and N, a traditional adjective (state V) may be interposed:

- (2.4.7.1b) *é ya ma+santfŋ # iŋ malatfŋ ígu?*  
*'The little rattan basket is not pretty.'*

Now the prefix *ma-* and other affixes of V, infixes and suffixes, do not show the same facility for transposition but are always bound. If one were to consider these particles as part of *masantfŋ* (as Bergaño and Castrillo do), one would have then:

*masantfŋya # iŋ ígu?*

A transcription of this type, if it is not to be arbitrary, would be hard put to account for the transposability of *ya* and the non-transposability of *ma-*.

Later chapters will show that some of these particles incorporated into V, freely transposable within V but never outside of V, are disyllabic and sometimes even discontinuous. Where disyllabic, they

often have their own accent. Hence, any attempt at a more detailed description of accent rules would have to postulate different types of boundaries within V.

## 2.5. PRONOUNS

Traditional pronouns (personal first, second, and third person; possessive; demonstrative; reflexive) in the frame of reference adopted in this study arise from various processes, notably incorporation and/or deletion as well as the direct symbolisation of non-lexically specified N matrices. Hence, they are not generated by a uniform process of a formative 'taking the place of a noun'.

### 2.5.1. Third Person Pronouns

In the sentence:

(2.5.1.1) mátas ya # i Pédro  
'Pedro is tall.'

ya does not take the place of i Pédro but by a process of incorporation copies features or specifications of SUBJECT N into V. If, however, Pédro is -new information, the lexical unit Pédro may be deleted after the incorporation process, leaving a matrix

N
selectional units
X
inflectional units

. By

a general deletion process which will be formulated later, such non-lexically specified matrices must be deleted. Thus:

(2.5.1.1a) mátas ya  
'He is tall.'

so that in effect, the traditional third person pronoun subject arises from the symbolisation of the copier N' by ya.  
SUBJECT

A similar process takes place to generate non-subject and non-oblique third person pronouns. In the sentence

(2.5.1.2) págarálan na niñ anák # iñ kífmika  
'Chemistry is being studied by the child.'

there is no copier for the subject because kífmika 'chemistry' (from Spanish quífmica) is both abstract and -count. The non-subject and non-oblique agent N is, however, copied as na. Now, if both the subject and the agent N's are -new, their lexical units can be deleted (both have to be -new since if only the agent N is -new, it would be subject). Once the lexical units are deleted, both N branches must be deleted.

The resulting sentence is:

(2.5.1.2a) págarálan na  
'He is studying [it].'

where now the incorporated copier na ( N' ) is the pronoun  
-SUBJECT  
-OBLIQUE

(actually the copier of anák).

It seems that the pronoun as a genuine proform or substitute for a noun arises only with oblique-marked N's. In the sentence:

(2.5.1.3)\* b+Intiyáy na ya nañ Pédrú # kañ Suán # in átu >  
biniyé neñ Pédrú # kañ Suán # in átu  
'The car was given by Pedro to Juan.'

if all N's were -new, the lexical unit in each of the N matrices would be deleted (after incorporation). This deletion of the lexical units triggers deletion of the whole N and of the whole N but  
SUBJECT -SUBJECT  
OBLIQUE -OBLIQUE

not of the N  
-SUBJECT  
OBLIQUE

Instead, it is directly symbolised as kayá:

(2.5.1.3a) biniyé ne # kayá #  
'He gave it to him.'

so that in effect, kayá symbolises not a copier (unlike ya and na) but

$$\left[ \begin{array}{l} \text{N} \\ \text{selectional units} \\ \text{x} \\ \text{inflectional units} \\ \text{OBLIQUE} \end{array} \right]; \text{ it is a genuine pro form.}$$

Not every third-person pronoun need arise from an original lexical unit in semantic structure. In other words, not every 'he/she/it' need arise from a noun root which is subsequently deleted. It could very well be that no lexical root is specified in semantic structure, because the person (or object) being referred to is present or is being pointed to. Thus, an initial sentence in a discourse may be:

(2.5.1.4) makagayák ya  
'He/She [the speaker points to a person who is approaching] is all dressed up.'

where the patient N is 
$$\left[ \begin{array}{l} \text{patient} \\ \text{N} \\ \text{selectional units} \\ \text{x} \\ \text{inflectional units} \\ \text{new} \\ \text{SUBJECT} \end{array} \right]. \text{ With the processes}$$

described thus far, such instances of N matrices without lexical units are easily accounted for as subsequently giving rise to pronouns. Like any SUBJECT N, the N of (2.5.1.4) is copied into V, the copier eventually symbolised as *ya*. Since N is not lexically specified, no deletion process is necessary to delete the root. The more general process already alluded to, however, applies: the whole N branch must be deleted.

Hence, it was necessary to posit a two-step deletion process: the first process deletes a noun root which is *-new*; the second process deletes any N branch which is not lexically specified and which is not oblique-marked. In this way, pronouns which arise from both *new* and *-new* N matrices are accounted for.

Moreover, since what is eventually symbolised in Pampangan are either N copiers with only inflectional specifications or OBLIQUE N's with only inflectional specifications (a process will be postulated in section 2.6.2.3 deleting selectional units), the lack of gender distinction for third-person pronouns in Pampangan finds a general explanation; hence, *ya* is a symbolisation for '*he/she/it*'.

## 2.5.2. First and/or Second Person Pronouns

The same processes already described for third-person pronouns apply to first and/or second person pronouns:

(2.5.2.1)	<i>másakít ku</i>	<i>'I am sick.'</i>
	<i>másakít ka</i>	<i>'You are sick.'</i>
	<i>másakít katá</i>	<i>'You and I are sick.'</i>

where the patient N is

[	N other selectional units (first person) (second person) inflectional units SUBJECT	]
---	--	---

N is selectionally specified by first and/or second person and not by a lexical unit, the incorporation process results in copying of certain specifications of N into V, including first and/or second person specifications. Thus:

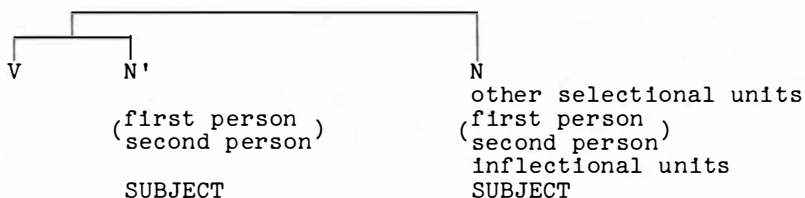

N, which is not lexically specified, is eventually deleted by the general deletion process already referred to.

The same processes apply to non-subject and non-oblique N's specified as first and/or second person:

- (2.5.2.2) burf ku # in pámagáral  
*'Studying is liked by me.'*
- burf mu # in pámagáral  
*'Studying is liked by you.'*
- burf ta # in pámagáral  
*'Studying is liked by you and me.'*

where the subject, because abstract, is not copied into V; only -SUBJECT -OBLIQUE N is copied as ku, mu, and ta. (Note that the symbolisation for subject first person N' is the same as for non-subject non-oblique first person N'). Again, what has happened is that the non-subject non-oblique N, selectionally specified as first and/or second person, is incorporated into V as N'; the N matrix is then deleted because not lexically specified; the symbolisation of N' in each instance generates the non-subject and non-oblique first and/or second person pronoun.

In the case of oblique-marked first and/or second person pronouns, no incorporation takes place but direct symbolisation of the oblique-marked non-lexically specified N matrices:

- (2.5.2.3) biniyé neñ Pédrú # kanáku # in áutu  
*'The car was given by Pedro to me.'*
- biniyé neñ Pédrú # kéka # in áutu  
*'The car was given by Pedro to you.'*
- biniyé neñ Pédrú # kékatá # in áutu  
*'The car was given by Pedro to you and me.'*

where the beneficiary N is

N other selectional units (first person ) (second person ) inflectional units OBLIQUE
--

### 2.5.3. Possessive Pronouns

In section 2.4.4, (T20') was formulated, yielding the output:

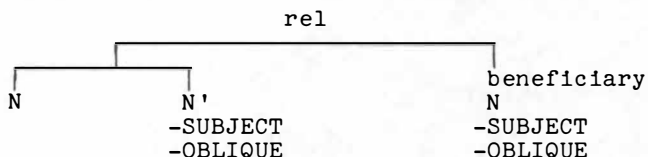

An example of a noun phrase with such a configuration is:

- (2.5.3.1) iŋ balé na niŋ anák  
'the house of the child'

where anák is a beneficiary N, the possessor, and balé is a patient N, the object possessed. Now, the oblique turned -oblique beneficiary N is copied into the patient N as na, the copier co-referential with niŋ anák. If, however, the lexical unit of the beneficiary N matrix is -new, then the root is deletable; once deleted, the non-lexically specified matrix must then be deleted, leaving:

- (2.5.3.1a) iŋ balé na  
'his house'

Hence, traditional possessive pronouns in Pampangan are actually non-subject and non-oblique N's, copiers incorporated into the N which refers to the object possessed:

- (2.5.3.2) iŋ balé ku                    'my house'  
iŋ balé mu                    'your house'  
iŋ balé ta                    'our (your and my) house'  
iŋ balé na                    'his/her/its house'

However, as variants of the above, one may likewise say:

- iŋ kanáku+ŋ balé            'my house'  
iŋ kéka+ŋ balé            'your house'  
iŋ kékatá+ŋ balé            'our (your and my) house'  
iŋ kayá+ŋ balé            'his/her/its house'

To account for the above variant expressions of possession, it will be necessary to postulate that the rule (T14') earlier postulated shifting oblique to -oblique specification for  $\overline{\text{N}} \text{ N}$  configurations is optional for

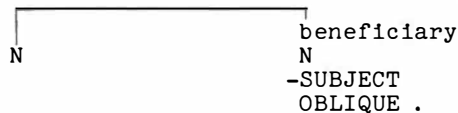

If (T14') is not applied, beneficiary N remains OBLIQUE. It must be subsequently interposed between the determiner and the root of N:

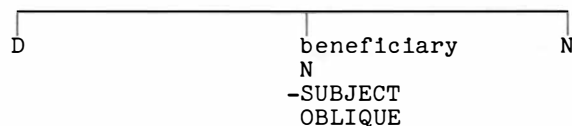

to yield a surface structure such as:

- (2.5.3.3) iŋ kaŋ Pédrutŋ balé  
*'the house [which belongs] to Pedro'*

The above phrase is less common than

- (2.5.3.3a)\* iŋ balé na naŋ Pédrú > iŋ balé naŋ Pédrú  
*'the house of Pedro'*

but is perfectly acceptable. Now, the lexical root of the beneficiary N of (2.5.3.3) may be deleted, if -new, to yield:

- (2.5.3.3b) in kayá+ŋ balé  
*'his house'*

where kayá is  $\left[ \begin{array}{l} \text{beneficiary} \\ \text{N} \\ \text{(no lexical root)} \\ \text{OBLIQUE} \end{array} \right]$ . Again, it should be noted that kayá

is not a copier but the direct symbolisation of a non-lexically specified oblique-marked N matrix.

In addition to revising (T14'), another rule will be necessary (a linearisation rule):

(T24') OBLIQUE N Insertion Rule

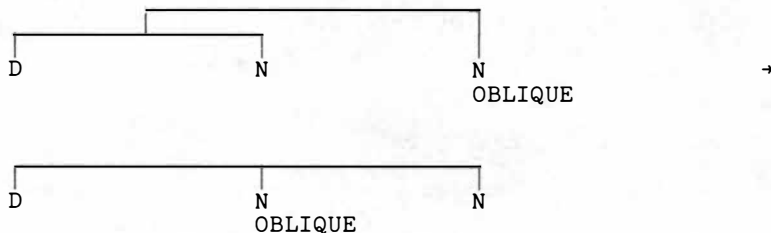

The above rule is a linearisation rule and comes much later in the derivational process (see section 2.7) but is formulated at this point because of its relevance to possessive pronouns.

#### 2.5.4. Demonstrative Pronouns

Traditional demonstrative pronouns arise from analogous processes, although the specification 'demonstrative' blocks the general deletion rule for non-lexically specified N matrices. In a sentence such as

- (2.5.4.1) masantíŋ ya # itáŋ balé  
*'That house is beautiful.'*

the unit 'demonstrative' is not copied into V under the N' matrix.

Subsequently, N is linearised as  $\overbrace{D \quad N}$ , with the unit 'demonstrative' under D and eventually symbolised as itá.

Now, if the root 'house' is -new, it may be deleted. Or if the root is not used to specify N in semantic structure (for example, if the speaker is pointing to the house), N may be non-lexically specified. In both cases, the rootless N matrix is not deleted; the unit 'demonstrative' prevents such deletion. Then, the whole N matrix is directly symbolised as:

- (2.5.4.1a) masantŋ ya # itá  
'Theat is beautiful.'

where the demonstrative pronoun itá is truly a pro form or substitute for itáŋ balé.

The same processes apply to non-subject demonstratives:

- (2.5.4.2)\* séli? na ya níta+ŋ táu # iŋ baláy >  
séli? ne nítaŋ táu # iŋ balé  
'The house was bought by that man.'

where nítaŋ táu is copied into V as na and where the non-subject and non-oblique determiner matrix contains the specification 'demonstrative' symbolised by níta. Again, if the non-subject and non-oblique matrix is without a lexical unit, one has:

- (2.5.4.2a) séli ne níta # iŋ balé  
'The house was bought by that man.'

Or:

- (2.5.4.2b) séli ne níta  
'It was bought by that [man].'

For oblique-marked demonstrative pronouns, no copying process need be postulated:

- (2.5.4.3) biniyé neŋ Pédrú # kaníta+ŋ táu # iŋ áutu  
'The car was given by Pedro to that man.'

Again, if for some reason, the beneficiary N matrix is without a lexical unit, one would have:

- (2.5.4.3a) biniyé neŋ Pédrú # kaníta # iŋ áutu  
'The car was given by Pedro to that [man].'  
(2.5.4.3b) biniyé ne # kaníta  
'It was given by him to that [man].'

#### 2.5.5. Summary of Rules for Pronouns

The following rules generate personal and demonstrative pronouns in Pampangan (they apply after the incorporation processes earlier formulated):

(T25') First and/or Second Person Incorporation into V  
Rule I

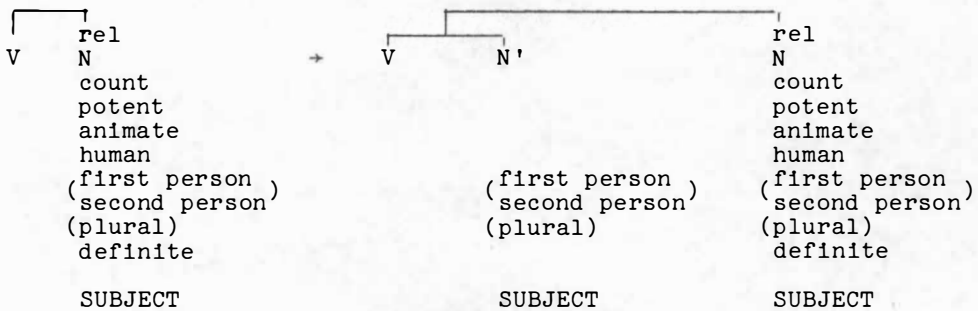

(T26') First and/or Second Person Incorporation into V  
Rule II

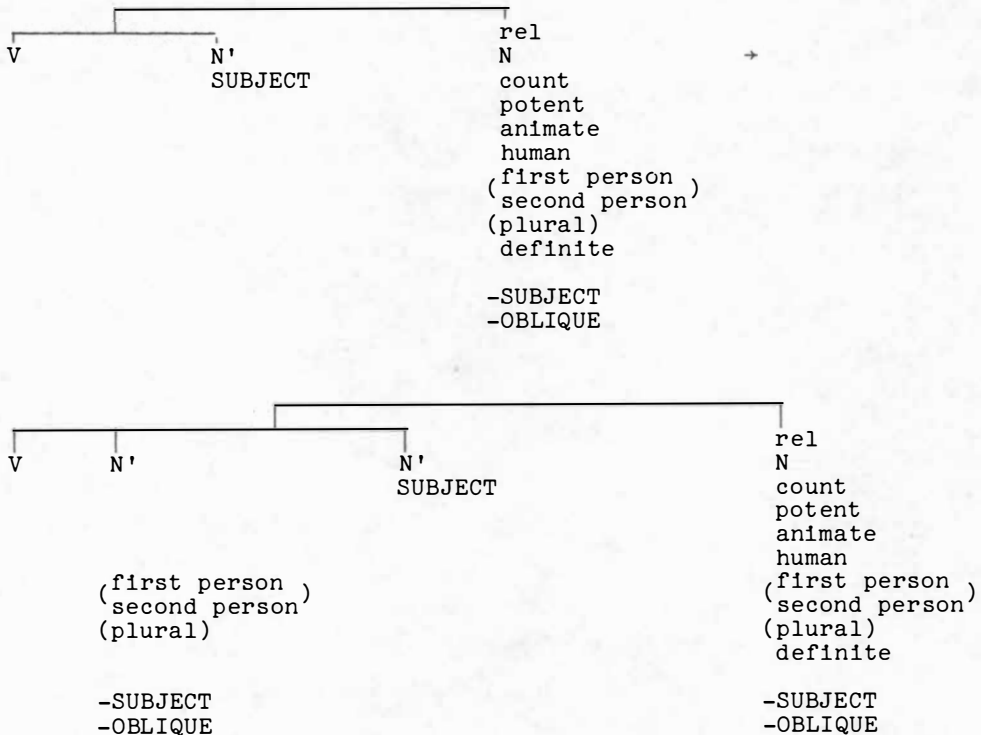

(T27') First and/or Second Person Incorporation into V  
Rule III

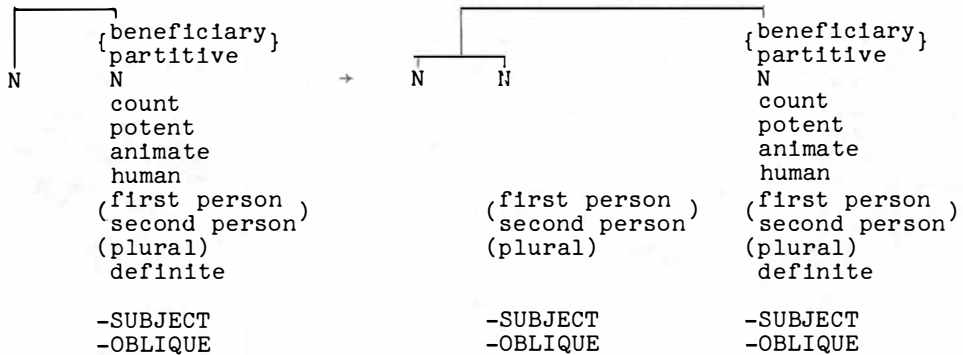

(Partitive has been included to account for noun phrases such as 'my head', where 'my' refers to the whole (partitive N) of which 'head' is a part).

(T28') Deletion of -new root in N rule



(T29') General Deletion Rule

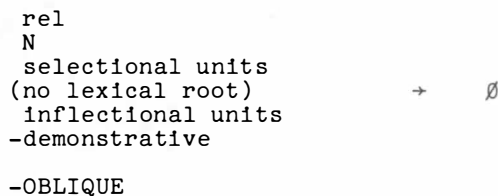

### 2.5.6. Symbolisation Rules for Personal and Demonstrative Pronouns

The matrices symbolised below result after other deletion processes have applied (notably, deletion of selectional units of N, to be formulated in section 2.6.2.3). Note that pronouns arise as a result of the symbolisation of N demonstrative and N OBLIQUE matrices as well as of N' matrices.

- (Sy 2.5.6.1) N'  
SUBJECT →  $\left\{ \begin{array}{l} iyá / \#\# \text{---} \\ yu / \bar{V} \text{---} \\ ya \quad atf \end{array} \right\}$  'he/she/it'
- (Sy2.5.6.2) N'  
plural →  $\left\{ \begin{array}{l} íla / \#\# \text{---} \\ lu / \bar{V} \text{---} \\ la \quad atf \end{array} \right\}$
- (Sy2.5.6.3) N'  
-SUBJECT  
-OBLIQUE → na
- (Sy2.5.6.4) N'  
plural  
-SUBJECT  
-OBLIQUE → da
- (Sy2.5.6.5) N  
-SUBJECT  
OBLIQUE → \*ka+ya > kayá
- (Sy2.5.6.6) N  
plural  
-SUBJECT  
OBLIQUE → \*ka+da+íla > \*kadéla > karéla
- (Sy2.5.6.7) N'  
first person  
SUBJECT →  $\left\{ \begin{array}{l} yáku / \#\# \text{---} \\ ku \end{array} \right\}$  'I'
- (Sy2.5.6.8) N'  
first person  
plural  
SUBJECT →  $\left\{ \begin{array}{l} ikamf / \#\# \text{---} \\ kamf \end{array} \right\}$  'we'
- (Sy2.5.6.9) N'  
first person  
plural  
-SUBJECT  
-OBLIQUE → ku
- (Sy2.5.6.10) N'  
first person  
plural  
-SUBJECT  
-OBLIQUE → mi
- (Sy2.5.6.11) N  
first person  
-SUBJECT  
OBLIQUE →  $\left\{ \begin{array}{l} *ka+\eta+aku > kanáku \\ *k+aku > káku \end{array} \right\}$

- (Sy2.5.6.12) N  
first person plural  
-SUBJECT  
OBLIQUE → \*ka+íkamí > kékamí ~  
keke
- (Sy2.5.6.13) N'  
second person  
SUBJECT → { íka / ##\_ } 'you'  
ka
- (Sy2.5.6.14) N'  
second person plural  
SUBJECT → { íkayú / ##\_ } 'you (plural)'  
kayú
- (Sy2.5.6.15) N'  
second person  
-SUBJECT  
-OBLIQUE → mu
- (Sy2.5.6.16) N'  
second person plural  
-SUBJECT  
-OBLIQUE → yu
- (Sy2.5.6.17) N  
second person  
-SUBJECT  
OBLIQUE → \*ka+íka > kéka
- (Sy2.5.6.18) N  
second person plural  
-SUBJECT  
OBLIQUE → \*ka+íkayú > kékayú ~  
keko
- (Sy2.5.6.19) N'  
first person  
second person  
SUBJECT → { íkatá / ##\_ } 'you and I'  
katá
- (Sy2.5.6.20) N'  
first person  
second person plural  
SUBJECT → { íkatámu / ##\_ } 'you (plural) and I'  
'you and we'  
támu 'you (plural) and we'
- (Sy2.5.6.21) N'  
first person  
second person  
-SUBJECT  
-OBLIQUE → ta

- (Sy2.5.6.22) N'  
first person  
second person  
plural → támu  
-SUBJECT  
-OBLIQUE
- (Sy2.5.6.23) N  
first person → \*ka+íkatá > kékatá  
second person  
-SUBJECT  
OBLIQUE
- (Sy2.5.6.24) N  
first person → \*ka+íkatámu > kékatámu  
second person  
plural  
-SUBJECT  
OBLIQUE
- (Sy2.5.6.25) N  
demonstrative → itá 'that (yonder)'  
SUBJECT
- (Sy2.5.6.26) N  
plural → \*da+itá > déta 'those (yonder)'  
demonstrative  
SUBJECT
- (Sy2.5.6.27) N  
demonstrative → \*n+itá > níta  
-SUBJECT  
-OBLIQUE
- (Sy2.5.6.28) N  
plural → \*da+itá > déta  
demonstrative  
-SUBJECT  
-OBLIQUE (cf. Sy2.5.6.26)
- (Sy2.5.6.29) N  
demonstrative → { \*ka+n+itá > kaníta }  
-SUBJECT { ka+ itá > kéta }  
OBLIQUE
- (Sy2.5.6.30) N  
plural → \*ka+da+itá > \*kadéta >  
demonstrative karéta  
-SUBJECT  
OBLIQUE
- (Sy2.5.6.31) N  
demonstrative → iní 'this (near me)'  
proximate to speaker  
SUBJECT

- (Sy2.5.6.32) N  
 plural  
 demonstrative → \*da+iní > déni 'these (near me)'  
 proximate to speaker  
 SUBJECT
- (Sy2.5.6.33) N  
 demonstrative → \*n+iní > níni  
 proximate to speaker  
 -SUBJECT  
 -OBLIQUE
- (Sy2.5.6.34) N  
 plural  
 demonstrative → \*da+da+iní > \*dadéni >  
 proximate to speaker daréni
- (Sy2.5.6.35) N  
 demonstrative → { \*ka+n+iní > kaníni }  
 proximate to speaker { \*ka+iní > kéni }  
 -SUBJECT  
 OBLIQUE
- (Sy2.5.6.36) N  
 plural demonstrative → \*ka+da+iní > \*kadéni >  
 proximate to speaker karéni  
 -SUBJECT  
 OBLIQUE
- (Sy2.5.6.37) N  
 demonstrative → iyán 'that (near you)'  
 proximate to hearer  
 SUBJECT
- (Sy2.5.6.38) N  
 plural  
 demonstrative → \*da+iyán > dén  
 proximate to hearer  
 SUBJECT 'those (near you)'
- (Sy2.5.6.39) N  
 demonstrative → \*n+iyán > niyán  
 proximate to hearer  
 SUBJECT  
 -OBLIQUE
- (Sy2.5.6.40) N  
 plural  
 demonstrative → \*da+da+iyán > \*dadén >  
 proximate to hearer darén  
 -SUBJECT  
 -OBLIQUE

- (Sy2.5.6.41) N  
demonstrative →  
proximate to hearer  
-SUBJECT  
OBLIQUE  
\*ka+iyán > kén
- (Sy2.5.6.42) N  
plural  
demonstrative →  
proximate to hearer  
-SUBJECT  
OBLIQUE  
\*ka+da+iyán > \*kadén >  
karén
- (Sy2.5.6.43) N  
demonstrative →  
proximate to speaker  
proximate to hearer  
SUBJECT  
ití  
'this (near you and me)'
- (Sy2.5.6.44) N  
plural  
demonstrative →  
proximate to speaker  
proximate to hearer  
SUBJECT  
\*da+ití > déti
- (Sy2.5.6.45) N  
demonstrative →  
proximate to speaker  
proximate to hearer  
-SUBJECT  
-OBLIQUE  
\*n+ití > níti
- (Sy2.5.6.46) N  
plural  
demonstrative →  
proximate to speaker  
proximate to hearer  
-SUBJECT  
-OBLIQUE  
\*da+da+ití > \*dadéti >  
daréti
- (Sy2.5.6.47) N  
demonstrative →  
proximate to speaker  
proximate to hearer  
-SUBJECT  
OBLIQUE  
{ \*ka+n+ití > kaníti }  
{ \*ka+ití > kéti }
- (Sy2.5.6.48) N  
plural  
demonstrative →  
proximate to speaker  
proximate to hearer  
-SUBJECT  
OBLIQUE  
\*ka+da+ití > \*kadéti >  
karéti

## 2.5.7. First and Second Person Pronouns in V

The rules formulated for N's specified as first and/or second person permit the incorporation of two first and/or second person N's into V. Thus:

(2.5.7.1) kalugurán mu kú  
'I am loved by you.'

where mu is a symbolisation for  $\left[ \begin{array}{l} \text{N'} \\ \text{second person} \\ \text{-SUBJECT} \\ \text{-OBLIQUE} \end{array} \right]$  and ku is a symbol-

isation for  $\left[ \begin{array}{l} \text{N'} \\ \text{first person} \\ \text{SUBJECT} \end{array} \right]$ . It is interesting to note that one cannot

say in Pampangan 'You love me' but only 'I am loved by you'. The reason for this is that patient/complement/instrument/measure N, when -SUBJECT, can never be definite, as was shown earlier. If it is definite, it must be extraposed and subjectivised. And since first and/or second person is always definite, any occurrence of first and/or second person in a patient/complement/instrument/measure N is always extraposed and subjectivised.

Using the frame

X	<i>is loved by</i>	Y
SUBJECT		-SUBJECT -OBLIQUE

one may consider all the possible first and/or second person and third person combinations. The different possibilities are charted in Table 1. In general, the combinations are as predicted, with the application of certain phonological rules comparable to those already outlined for  $\overline{\text{N' N}}$  combinations for third persons, except for two combinations which will be explained.

Reflexive structures such as 'I am loved by myself' are not charted. Reflexive pronouns will be discussed in the next section.

Two combinations are irregular; they are noted by double lines in Table 1. In a sentence such as 'You are loved by me', if the occurrence of N copiers were perfectly regular, one would expect:

(2.5.7.2) <sup>x</sup>kalugurán ku ká

Instead, one has:

(2.5.7.2) kalugurán da ká

which also means 'You are loved by them'. Moreover, if one wanted to say 'You are loved by us', the expected combination would be:

SUBJECT								
	First Person	First Person Plural	Second Person	Second Person Plural	First Person	First Second Person Plural	Third Person	Third Person Plural
-SUBJECT -OBLIQUE								
First			*ku ka da ká	*ku kayú da kayú			*ku ya > ke	ku la
First Plural			*mi ka da ká	*mi kayú da kayú			*kamf ya > mi ya	*kamf la > mi lá
Second	mu kú	mu kamf					*mu ya > me	mu lá
Second Plural	yu kú	yu kamf					*yu ya > ye	yu lá
First							*ta ya > te	ta lá
Second								
First							*támu ya > tá ya	támu la > tá la
Second								
Plural								
Third	ná ku	na kamf	na ká	na kayú	na katá	na katámu	*na ya > ne	na lá
Third	dá ku	da kamf	da ká	da kayú	da katá	da katámu	*da ya > de	da lá
Plural								

TABLE 1

(2.5.7.2) <sup>x</sup>kalugurán ku ká

Instead, one has:

(2.5.7.2) kalugurán da ká

which also means 'You are loved by them'. Moreover, if one wanted to say 'You are loved by us', the expected combination would be:

(2.5.7.3) <sup>x</sup>kaluguránmi ká

Instead, however, one must say:

(2.5.7.3) kalugurán da ká

which means 'You are loved by us' as well as 'You are loved by me' and 'You are loved by them'. If one wanted to disambiguate (2.5.7.3), one would say:

(2.5.7.3a) yáku # kalugurán da ká  
'As for me, you are loved by me.'

(2.5.7.3b) íkamf # kalugurán da ká  
'As for us, you are loved by us.'

The same kind of ambiguity arises with:

(2.5.7.4) kalugurán da kayú

which may mean:

'You (plural) are loved by them.'

'You (plural) are loved by me.'

'You (plural) are loved by us.'

To disambiguate the last two meanings, one would say:

(2.5.7.4a) yáku # kalugurán da kayú  
'As for me, you (plural) are loved by me.'

(2.5.7.4b) íkamf # kalugurán da kayú  
'As for us, you (plural) are loved by us.'

The preceding double ambiguity is explained by a post-semantic neutralisation rule

(T30') First Person (Plural) Neutralisation Rule

N'	→	N'	/	V	N'	N'
first person						second person
(plural)		plural				(plural)
-SUBJECT		-SUBJECT		—		SUBJECT
-OBLIQUE		-OBLIQUE				

## 2.5.8. Reflexive Pronouns

Traditional reflexive pronouns in Pampangan arise when the agent N and the patient N are co-referential in a process-action V and when the agent N and the beneficiary or goal N are co-referential in an action V. The formative symbolising 'self' is \*sa+díli > saríli, which is best considered as introduced post-semantically. Consider the sentence:

- (2.5.8.1) papatén neḡ Pédru # iḡ saríli na  
*<sup>x</sup>'His self is being killed by Pedro.'* =  
*'Pedro is killing himself.'*

Note that in reflexive sentences, the formative 'self' is always definite and therefore either SUBJECT (as in the above) or OBLIQUE (as in the following example):

- (2.5.8.2) gágámit yaḡ larú? # kiḡ saríli na # i Pédru  
*'Pedro is using oil on himself.'*

Note too that 'self' is referentially neutral; it is specified by the copier incorporated into it, in this case, by na. Other copiers possible are:

- (2.5.8.3) kúkuskusán ku # iḡ saríli ku  
*<sup>x</sup>'My self is being wiped by me.'*  
 kúkuskusán me # iḡ saríli mu  
*<sup>x</sup>'Your self is being wiped by you.'*  
 kúkuskusán ta # iḡ saríli ta  
*<sup>x</sup>'Your and my self is being wiped by you and me.'*

To account for the post-semantic introduction of saríli, the necessary context is co-referentiality. What seems to happen is the following (taking 2.5.8.1 as an example):

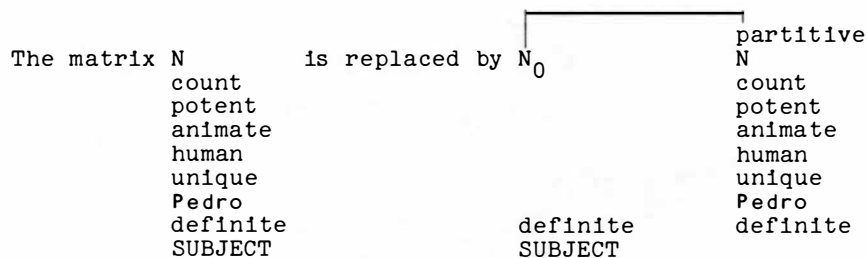

where the zero subscript for the first N is a notation for referential neutrality. Since one cannot say in Pampangan:

- (2.5.8.4) *<sup>x</sup>kaḡ Pédru # iḡ saríli na*  
*<sup>x</sup>'His self is part of Pedro.'*

the  $\overline{N}$  N configuration does not seem to arise from an underlying state V (as does *iŋ buntúk naŋ Pédru* 'the head which is part of Pedro' = 'Pedro's head') but is a direct replacement of N in a context of co-referentiality. Once the  $\overline{N}$  N configuration is generated, the usual rules for such configurations follow. Partitive is initially marked as OBLIQUE but then is shifted to -OBLIQUE. Then partitive N is copied into  $N_0$  (symbolised by *na*); since the root of the partitive N is -new (it is the same root found in the agent N matrix), it is deleted, leaving an N matrix without lexical specification and therefore deletable. The surface structure of the resulting noun phrase is:

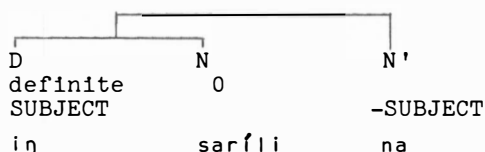

The relevant rule for generating reflexive pronouns is therefore:

(T31') Reflexive Rule

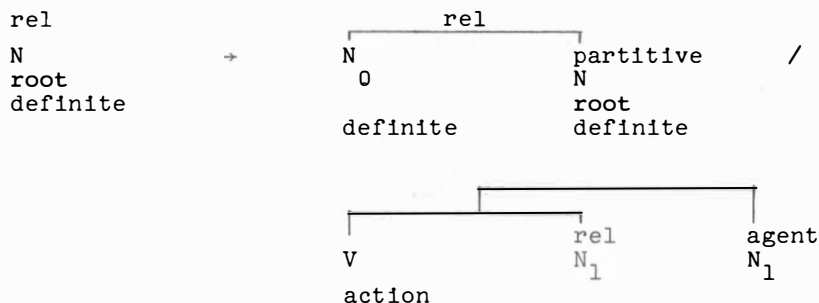

In Chapter I, sentences such as the following were cited:

- (2.5.8.5) *máŋpakamaté ya # i Pédru*  
'Pedro is committing suicide.'
- (2.5.8.6) *pálákad ya # i Pédru*  
'Pedro is having himself walked [by somebody].'  
'Pedro is managung [e.g. a factory].'

The above sentences are best accounted for as idioms, the semantic verb root 'to commit suicide' being literalised by *die+causativiser<sub>1</sub>* + *deprocessiviser* + *exertiviser*. In the second sentence, two separate roots 'to cause oneself to be walked [by somebody]' and 'to manage [something]' are both literalised as *walk + causativiser<sub>2</sub>*. Hence, the question of reflexive pronouns does not even arise in accounting for the above sentences.

## 2.6. REPLACEMENTS: DELETIONS AND NEUTRALISATIONS

In the preceding section on pronouns, deletion processes have already been discussed and a general deletion rule formulated. The deletion processes already discussed will be reformulated. The deletion processes already discussed will be recapitulated and discussed within a more comprehensive view of deletion processes in the language. In addition to deletions, an important neutralisation process was discovered which promises a partial solution to the thorny problem of verb subject markers in Pampangan.

The processes to be discussed in this section all involve replacement:

$$\begin{array}{l} \text{unit a} \quad \rightarrow \quad \text{unit b} \\ \\ \text{unit a} \quad \rightarrow \quad \left[ \begin{array}{l} \text{unit b} \\ \text{unit c} \\ \text{unit d} \end{array} \right] \end{array}$$

A particular type of replacement is:

$$\begin{array}{l} \text{unit a} \quad \rightarrow \quad \emptyset \\ \\ \left[ \begin{array}{l} \text{unit a} \\ \text{unit b} \\ \text{unit c} \end{array} \right] \quad \rightarrow \quad \emptyset \end{array}$$

which is, of course, deletion. On the other hand, one may have a replacement process such as:

$$\begin{array}{l} \left[ \begin{array}{l} \text{unit a} \\ \text{unit b} \\ \text{unit c} \end{array} \right] \quad \rightarrow \quad \text{unit a} \\ \\ \left[ \begin{array}{l} \text{unit a} \\ \text{unit b} \\ \text{unit c} \end{array} \right] \quad \rightarrow \quad \text{unit d} \end{array}$$

where, in effect, earlier established contrasts or oppositions are neutralised into a common unit; hence, the process is one of neutralisation.

This rather simplified typology has been adopted merely as a means of unifying the discussion of processes to be discussed in this section. A more detailed analysis will surely reveal other sub-types and render more subtle distinctions necessary.

Replacement, deletion, and neutralisation processes relevant to V's will first be discussed; then those relevant to N's. In general, the general principle is that all units necessary for symbolisation

must be retained, while those unnecessary for symbolisation must be post-semantically deleted: hence, in the theory, zero morphs, which troubled American structuralists so much, do not arise, since such zero morphs will have been deleted prior to the symbolisation process. Moreover, instances of ambiguity and polysemy are accounted for by either general replacement or neutralisation processes, whereby semantic distinctions are post-semantically neutralised in surface structure.

### 2.6.1. Replacements in V

#### 2.6.1.1. Deletion of V

Examples have been given in Chapter I of sentences which in surface structure have no verbs (favouritive/partitive/intentive/temporal/locative/possessive state V's). To cite only one example:

(2.6.1.1.1) kaŋ Pédro ya # iŋ áutu  
                   '*The car belongs to Pedro.*'

where the possessive state V matrix is not lexically specified by a verb root. Since V receives no symbolisation, it must be postulated as post-semantically deleted:

(T32') V Deletion Rule

V	→	∅
state		
(no lexical root)		

#### 2.6.1.2. Deletion of V Selectional Units

Once V has been narrowed down to a particular lexical unit, a verb root (basic or derived), the selectional units which functioned to narrow it down are no longer necessary and must consequently be deleted:

(T33') Deletion of V Selection Units Rule

V		V
x		
root	→	root
y		y

where x = selectional units; y = inflectional units

If a selectional unit is necessary as a context for later processes or for symbolisation, it must be retained; no such units were discovered for V.

### 2.6.1.3. Deletion of V Derivational Units

Because of the centrality of the verb as the nucleus of a sentence, a basic verb root, once selected, is never deleted in a  $\overline{V \quad N}$  structure. Of course, if a verb root were never selected in semantic structure, the Verb Deletion Rule (T32') would apply, in effect deleting the whole V branch. In Chapter III, however, where  $\overline{V \quad V}$  structures are discussed, the second occurrence of a verb root is a context for deletion, since the second root is then -new.

However, derivational units added to basic verb roots, if they are not eventually symbolised, must be inferred to be post-semantically deleted. In a more adequate grammar, such units must be marked by deletion-rule features in the lexicon. For example, among the derivational units posited in section 1.1.7 (see pages 64-5), the following units must be deleted: (1) processiviser: In a sentence such as *lalakáran na laḡ Pédro # diḡ úbas* 'The grapes are being trampled on by Pedro', the verb root is analysable as *walk* + processiviser. The unit is necessary to transform the action verb into a process-action verb. Since, however, -an is not a derivational unit but a marker for patient subject, processiviser receives no symbolisation and must then be inferred to be deleted. Thus, both the action verb root and the process-action verb root receive the same symbolisation, *lákad*. (2) deprocessiviser: In a sentence such as *púpútut ya # i Pédro* 'Pedro is cutting [something]', the inherent process-action verb root *pútut* has become an action verb root but with no change in symbolisation; hence, the unit deprocessiviser must be posited as deleted. (3) predicativiser: In *ának ya # i Pédro* 'Pedro is a child', the derived state V, *child* + predicativiser, receives the same symbolisation as 'child'; hence, predicativiser is postulated as deleted. (4) descriptiviser: In *ának ya # i Pédro* 'Pedro is young', the derived state V is *child* + descriptiviser; again, since the verb receives the same symbolisation as 'child', the unit descriptiviser must be postulated as deleted. (5) action verbaliser<sub>2</sub>: In *kákamagának ya # i Pédro* 'Pedro is engaging in the activity of making relatives', the derived action V, *relative* + action verbaliser<sub>2</sub> must be postulated as deleted. (6) process-action verbaliser: In *ánakan neḡ Suán # i Maryá* 'Maria will conceive because of Juan', the derived process-action V, *child* + process-action verbaliser, receives the same symbolisation as 'child', since -an is not a derivational unit but a marker for subject choice. Hence, the derivational unit must be postulated as deleted.

For the deletion of derivational units, particular rules will be necessary. Only a general rule (suggestive of the type of rule necessary) will be formulated:

## (T34') V Derivational Units Deletion Rule

V	→	V
root + derivational unit		root

## 2.6.1.4. Deletion and Replacement of V Inflectional Units

In Chapter I, V's were described as inflectionally specifiable by 'generic'.

In state V's, 'generic' receives no symbolisation and hence must be postulated as deleted; however, in non-state V's, 'generic' receives the same symbolisation as actual durative aspect:

(2.6.1.4.1) *lálákad ya # i Pédro*  
*'Pedro is walking [right now].'*  
*'Pedro walks [habitually].'*

Hence, a post-semantic rule must be posited replacing 'generic' by 'actual durative'.

Aspectual deletion rules must likewise be posited. In the above sentence, the unit 'actual' is not symbolised, 'durative' being symbolised by the re-duplication. Hence, it must be posited as deleted. Neither does the unit 'actual' receive any symbolisation in

(2.6.1.4.2) *línákad ya # i Pédro*  
*'Pedro walked.'*

where the unit 'completed' is symbolised by -in-. Moreover, in the following sentence, neither 'actual' nor 'completed' is symbolised but only 'immediate' (symbolised by ka- and reduplication of the whole root):

(2.6.1.4.3) *kalákadlákad na pá muḡ # Pédro*  
*'Pedro has just now walked.'*

The replacement and deletion processes postulated may be formulated by the following rules:

## (T35') Generic Deletion Rule

V		V
state		state
root	→	root
generic		

## (T36') Generic Replacement Rule

V		V
-state		-state
root	→	root
generic		actual durative

## (T37') Actual Deletion Rule

V	V
-state	-state
root	root
actual	
{durative }	{durative }
{completed }	{completed }

## (T38') Actual Completed Deletion Rule

V	V
-state	-state
root	root
actual	
completed	
immediate	immediate

## 2.6.1.5. Deletion and Neutralisation of Some V Subject Specifications

In section 2.1.4, an incorporation rule (T11') was formulated whereby the choice of subject is mirrored in the verb root as an inflectional specification of V. Hence, after the application of the incorporation rule, the V matrix is:

V
selectional units
root
inflectional units (aspect and repetition)
incorporated rel subject

Consider the following sentences, however:

- (2.5.1.5.1) makába yaŋ aduáŋ kilómetru # Iŋ dálan  
'The road is two kilometres long.'

where the patient N is subject. Now the verb root must be accompanied by a patient N as subject; no other subject is permitted. Yet, there is no overt subject marker, although semantically there is an incorporated specification 'patient subject'. The root is kába? 'length'; ma- is a derivational unit 'plenitiviser' and not a subject marker.

In general, there is a danger, in analysing the Philippine languages, to confuse derivational units like ma- with subject markers, which are often Ø. It is interesting to note that Bergaño distinguishes subject markers and derivational units quite clearly in his *Arte*; the overt subject markers he discusses under his 'tres pasivas' as voice markers (which they are) and the overt derivational units he discusses in a separate chapter as 'proto-compuestos' (his term for prefixed roots). Although eventually both subject markers and derivational units appear in symbolisation as verbal affixes, the two types of units are totally distinct types and must be so distinguished if confusion is not to result.

It is not only the specification 'patient subject' which is not overtly marked in the root of state V's but likewise other types of subject specification. For example, in:

(2.6.1.5.2) burf naŋ Pédrú # iŋ pámaŋán  
'The food is liked by Pedro.'

(2.6.1.5.3) b'isa yaŋ pámaŋán # i Pédrú  
'Pedro wants [some] food.'

neither buri? nor bisa? are overtly marked by 'patient topic' and 'experiencer topic', though both clearly must have these incorporated specifications since no other subject choice is possible.

Again, in a motivative state V:

(2.6.1.5.4) mákatúla ya # iŋ búbu  
'The clown is motivative of laughter.'

the verb root has no overt marker for the motive subject since máka- is not a subject marker but a derivational unit 'motivativiser'.

As a final example, one may cite:

(2.6.1.5.5) kasíŋ kátas neŋ Pédrú # iŋ anák  
'The child is as tall as Pedro.'

where again, the verb root must be accompanied by a patient subject; this obligatory specification 'patient subject' finds no overt marking, however, since kasíŋ and the m to k shift in mátas 'tall' is a symbolisation for 'equatativiser'.

Hence, a deletion rule which in effect deletes all incorporated subject specifications in a state V must be formulated:

(T39') Subject Specification Deletion Rule I

V		V
state		state
root	→	root
rel subject		

For process V's, except for the instances which will be discussed below, the same type of deletion seems to occur:

(2.6.1.5.6) mamamaté ya # iŋ táu  
'The man is dying.'

where the verb root \*matáy, which is specified as 'patient subject', has no overt marker for this specification. Again:

(2.6.1.5.7) mágkasakít ya # i Pédrú  
'Pedro is getting to have a sickness.'

where the obligatory beneficiary N subject is not overtly marked in the verb root, since magka- is a derivational unit meaning 'habitiviser'.

Or:

(2.6.1.5.8) mánákit yaŋ baié # i Pédrú  
'Pedro is seeing a house.'

where the experiencer N Pédro is subject; there is no overt marking for this subject specification since the verb is analysable as 'see' and inflectional marker for 'repetitive' symbolised by \*-ḡa-, hence, literally, 'to see repeatedly', where the experiential process of seeing seems to have been originally conceived of as a series of discrete successive experiences. In

- (2.6.1.5.9)\* máḡ+kailáḡan yaḡ áutu # i Pédro >  
 máḡailáḡan yaḡ áutu # i Pédro  
 'Pedro is needing a car.'

maḡ- is not a subject marker but a derivational unit which derives a state V, kailáḡan 'in a state of need', into a process V.

It seems that the subject specification is overtly marked only when the original configuration has been disturbed, in other words, when an extra-position rule has been applied. Hence:

- (2.6.1.5.10) méragúl yaḡ aduáḡ pulgáda # iḡ anák  
 'The child grew big by two inches.'

but

- (2.6.1.5.10a) KÉragulÁN na la niḡ anák # diḡ aduáḡ pulgáda  
 'The two inches were grown by the child.'

This matter, however, demands further study, since in the sentence

- (2.6.1.5.11) ákákit neḡ Pédro # iḡ balé  
 'The house is being seen by Pedro.'

there is no overt marker for the patient subject selection although the unmarked subject for experiential process V's is the experiencer N (see sentence 2.6.1.5.8).

Moreover, in a sentence such as:

- (2.6.1.5.12) KÉmatéN yaḡ kalugurán # i Pédro  
 'Pedro was bereft of a loved one.'

the choice of beneficiary subject is overtly marked by \*ka-....-an although no extra-position was necessary, since the beneficiary N is usually attached to the configuration after the patient N.

The following rule is therefore formulated with the proviso that certain roots will be exceptions:

(T40') Subject Specification Deletion Rule II

V	→	V	
process		process	
root		root	/if no extra-position rules
rel subject			have applied

It is with action V's and process-action V's that most problems arise with regard to the symbolisation of the subject specification. To begin with, if the V specification is 'agent subject', it is never overtly marked and therefore the specification must be postulated as deleted:

- (2.6.1.5.13) lálákad ya # i Pédrú  
'Pedro is walking.'
- (2.6.1.5.14) pálákad ya # i Pédrú  
'Pedro is managing something.'
- (2.6.1.5.15) mágáral ya # i Pédrú  
'Pedro is studying.'

where pa- is a marker for 'causativiser<sub>2</sub>' and where mag- is a marker for a derivational unit 'activatvise'. The following rule may therefore be formulated:

(T41') Subject Specification Deletion Rule III

V		V
(process)		(process)
action		action
root	→	root
agent subject		

Consider now the following sentences:

- (2.6.1.5.16) puputúTAN neḡ Pédrú # iḡ dútuḡ  
patient subject  
'The wood is being cut by Pedro.'
- (2.6.1.5.17) babásAN neḡ Pédrú # iḡ librú  
complement subject  
'The book is being read by Pedro.'
- (2.6.1.5.18) gagamftAN neḡ Pédrú # iḡ lagári?  
instrument subject  
'The saw is being used by Pedro.'
- (2.6.1.5.19) lalakárAN na iḡ Pédrú # diḡ aduáḡ kilómetru  
measure subject  
'The two kilometres are being walked by Pedro.'
- (2.6.1.5.20) dirínAN neḡ kuáltan Pédrú # i Suán  
beneficiary subject  
'Juan is being given money by Pedro.'
- (2.6.1.5.21) pupuntAN neḡ Pédrú # iḡ balé  
goal subject  
'The house is being gone to by Pedro.'

- (2.6.1.5.22) íbatÁN neḡ Pédrú # iḡ balé  
source subject  
x *'The house is being come from by Pedro.'* =  
*'Pedro is coming from the house.'*
- (2.6.1.5.23) gagáwAN neḡ lamésaḡ Pédrú # iḡ dútuḡ  
material subject  
*'The wood is being made into a table by Pedro.'*
- (2.6.1.5.24)\* máki+lákad+an na ya naḡ Pédrú # i Suán >  
PakilakárAN neḡ Pédrú # i Suán  
associate subject  
*'Juan is being joined by Pedro in walking.'*
- (2.6.1.5.25) pálakárAN neḡ Pédrú # i Suán  
agentive beneficiary subject  
*'Juan is being caused to walk by Pedro.'*

What the examples above show is that different subject specifications are neutralised into a common subject marker symbolised by suffix -an. This post-semantic neutralisation of various subject specifications into a common subject specification has caused undue confusion among certain linguists who have examined the Philippine languages. Some have subsumed all the above subject specifications under 'goal'. To do this, however, would be to return to the search for a 'common or basic meaning' for the surface subject marker, an enterprise that has proven unsatisfactory thus far. Only by straining can one consider the subject in sentence (2.6.1.5.22) as a 'goal', in this analysis, a source N. Another proposal has been to consider -an a general marker for a subject specification describable as 'unspecified locus'. Again, however, it is highly artificial to consider patients, complements, instruments, and measures as in any way locative. The more economical and certainly the more semantically plausible analysis would be to posit as many N relations to V as there are discoverable and then to postulate post-semantic rules to account for the convergences in symbolisation. In this case, what has happened can be accounted for by the following neutralisation rule:

## (T42') Subject Specification Neutralisation Rule I

V (process) action root*	→	V (process) action root*	
patient subject complement subject instrument subject measure subject beneficiary subject goal subject source subject material subject associative subject agentive beneficiary subject		common subject	a

where root\* means that this neutralisation rule applies to a particular subset of verb roots (a large subset); one cannot formulate a rule that applies to all roots since certain roots are not subject to this neutralisation rule. Moreover, common subject<sub>a</sub> indicates that there is more than one type of common subject. Thus:

- (2.6.1.5.26) Itúlak neḡ Pédrú # iḡ áutu  
 patient subject  
*'The car will be pushed by Pedro.'*
- (2.6.1.5.27) Ibiyé neḡ Pédrú # iḡ áutu  
 complement subject  
*'The car will be given by Pedro.'*
- (2.6.1.5.28) Igawá neḡ piyáílúḡan Pédrú # iḡ anák  
 beneficiary subject  
*'The child will be made for a toy by Pedro.' =*  
*'Pedro will make a toy for the child.'*

where patient, complement, and beneficiary subject are symbolised by a common subject marker i-. For the above verb roots, -an cannot be used as a symbolisation for the same subject specification. Another neutralisation rule may then be formulated:

## (T43') Subject Specification Neutralisation Rule II

V (process) action root**	→	V (process) action root**	
patient subject complement subject beneficiary subject		common subject <sub>b</sub>	

where root\*\* is an abbreviation for a subset of verb roots that take i- as a subject marker.

Undoubtedly, the deletion and neutralisation rules formulated would have to be expanded as the verb lexicon of Pampangan is more thoroughly investigated.

Below are listed the most common verb affixes which symbolise subject specification (in addition to -an and i-):

-anan	goal subject source subject
ipaŋ-	instrument subject beneficiary subject
pag-	beneficiary subject
*m>p-...-an	complement subject associate subject location subject
ka-...-an	beneficiary subject location subject time subject motive subject
aka-	motive subject

Bergaño cites only 'tres pasivas' or non-agent subject markers in his Arte (i-, -an, -anan) although the other affixes occur in his corpus. -anan seems to be a variant of -an, although in the following example, -anan is clearly preferable:

- (2.6.1.5.29) sulat<sup>Á</sup>ANAN neŋ Pédrú # i Suán  
'Juan will be written to by Pedro.'

On the other hand, -anan can not be used in the following:

- (2.6.1.5.30) sulúŋAN neŋ Pédrú # iŋ balé  
'The house will be proceeded to by Pedro.'

In the following sentence, -anan is obligatory:

- (2.6.1.5.31) kuan<sup>Á</sup>ANAN neŋ péraŋ Pédrú # i Suán  
x 'Juan will be gotten from money by Pedro.' =  
'Pedro will get money from Juan.'

And in

- (2.6.1.5.32) punt<sup>Á</sup>ANAN na laŋ Pédrú # diŋ kálugúran na  
'His friends will be gone to by Pedro.'

-anan has taken on (perhaps because of the reduplication) the added meaning of repetition or plurality of event.

## 2.6.2. Replacements in N

## 2.6.2.1. Deletion of Noun Root

In a semantic configuration, if a noun root is repeated, it is no longer new information. In such instances, it is optionally deletable, unless it is specified as TOPIC. The rule may be stated thus:

(T44') Noun Root Deletion Rule

rel		rel
N		N
x		x
root	- +	
y		y
-new		-new
-TOPIC		-TOPIC

where x = selectional units, y = inflectional units

In simple  $\overline{V} \quad \overline{N}$  configurations the deletion of a noun root is straightforward; in more complicated  $\overline{V} \quad \overline{V}$  configurations, however, where there is a hierarchy of N's arising from embeddings, the order of deletion is significant (such deletions in  $\overline{V} \quad \overline{V}$  configurations will be discussed in Chapter III).

## 2.6.2.2. Deletion of N

After incorporation processes have applied (resulting in the copying of specifications of N into V), there is a general rule (probably with parallels in other languages) whereby an N branch is deleted, if it has no lexical unit (the process is comparable to the deletion of V branches when V has no lexical unit), provided N is neither specified as OBLIQUE nor as TOPIC. The rule may be stated thus:

(T45') N Deletion Rule

N		
x	→	∅
(no root)		
y		
-OBLIQUE		
-TOPIC		

It is necessary to posit a two-step deletion process (Step 1: deletion of noun root; Step 2: deletion of N branch) since the second process (T45') is a more general rule, applicable to an N matrix which was not lexically specified by a noun root even in semantic structure (as in first and/or second person pronouns).

### 2.6.2.3. Deletion of N Selectional Units

After N has been lexically specified by a noun root, selectional units for N are superfluous and must be post-semantically deleted. However, unlike V selectional units, all of which are deleted, certain N selectional units are retained, where they are relevant for surface structure and eventual symbolisation. For example, unique human N's are distinguished in surface structure by the special determiner *i* (which is not used for unique -human N's). Moreover, as was shown in the section on classifiers in Chapter I, certain criterial selectional units are retained for the proper symbolisation of counters and measures. These criterial selectional units include '*clustered*' and '*twisted off*' for the symbolisation of *píliŋ* '*granular*' for the symbolisation of *bútil*, '*sliceable*' for *kapútut*, '*frangible*' for *kapirásu*. A general rule may thus be formulated:

(T46') N Selectional Units Deletion Rule

$$\begin{array}{c}
 \text{N} \\
 \times \\
 \left\{ \begin{array}{l}
 \langle (\text{classificatory specifications}) \rangle \\
 \left[ \begin{array}{l}
 (\text{human}) \\
 (\text{unique})
 \end{array} \right] \\
 \text{root} \\
 \langle (\text{counter/measure}) \rangle \\
 \text{y}
 \end{array} \right\} \rightarrow \\
 \text{N} \\
 \left\{ \begin{array}{l}
 \langle (\text{classificatory specifications}) \rangle \\
 \left[ \begin{array}{l}
 (\text{human}) \\
 (\text{unique})
 \end{array} \right] \\
 \text{root} \\
 \langle (\text{counter/measure}) \rangle \\
 \text{y}
 \end{array} \right\}
 \end{array}$$

### 2.6.2.4. Deletion of N Derivational Units

Among the N derivational units discussed in section 1.2.3. (see page 65), the only derivational unit which is to be deleted is the unit complementiser. In *makába? # iŋ lákad na* '*His trip is long*', *lákad* is analysable as *walk* + complementiser; since its symbolisation is identical with that of '*walk*', complementiser must be postulated as deleted. In general, it seems that noun derivational units are less subject to deletion than verb derivational units. The process may be formulated thus:

(T47') N Derivational Units Deletion Rule

$$\begin{array}{ccc}
 \text{N} & & \text{N} \\
 \text{root} + \text{derivational unit} & \rightarrow & \text{root}
 \end{array}$$

## 2.6.2.5. Deletion and Replacement of N Inflectional Units

Consider the sentence:

- (2.6.2.5.1) muntá ya # kiŋ Méníla? # i Pédrú  
'Pedro is going to Manila.'

One may likewise say:

- (2.6.2.5.1') muntá ya # Méníla? # i Pédrú

Again, consider the sentence:

- (2.6.2.5.2) kákawé ya # kiŋ ílug na niŋ Pampáŋga # i Pédrú ~  
kákawé ya # kiŋ ílug Pampáŋga # i Pédrú  
'Pedro is swimming in the river [which is part of Pampanga].'

It seems that the inflectional specifications of unique place N's are optionally deletable:

(T48') N Inflectional Units Deletion Rule I

N place unique root y	- →	N place unique root
-----------------------------------	-----	------------------------------

In a complete grammar, (T48') would have to be applied before the application of (T46'), which deletes selectional units of N.

In a sentence such as:

- (2.6.2.5.3) matápaŋ ía # di Pédrú  
'Pedro and [his] companions are brave.'

the determiner di is a symbolisation for

[	human unique definitive associative plural	]	.
---	--	---	---

However, since i is a symbolisation for

[	human unique definite	]	and d- is the
---	-----------------------------	---	---------------

usual symbolisation for plural, it seems that post-semantically, the 'associative' is deleted:

(T49') Associative Deletion Rule

N human unique root definite associative plural	→	N human unique root definite plural
---	---	--

In the sentence:

- (2.6.2.5.4) mámaṅán yaṅ ságin # i Pédrú  
 'Pedro is eating [a] banana.'  
 'Pedro is eating bananas.'

the non-subject and non-oblique patient N is neutralised as to number specification by the deletion of the unit 'plural':

(T50') N Plural Deletion Rule

N		N
root	→	root
plural		
-definite		-definite
-SUBJECT		-SUBJECT
-OBLIQUE		-OBLIQUE

The deletion of the unit 'total' in N' has already been mentioned:

- (2.6.2.5.5) mámaṅán la # diṅ gaṅ ának ~  
 mámaṅán laṅán # diṅ gaṅ ának  
 'All the children are eating.'

In cases where both N's are specified as 'total', the marker of the first N' is obligatorily deleted:

- (2.6.2.5.6)\* atí luṅṅan # di gaṅ Pédrú >  
 atí luṅán # di Pédrú  
 'Pedro and [his] companions are all here.'

The rules may be stated thus:

(T51') Total Deletion Rule I

N'	- →	N'
total		

(T52') Total Deletion Rule II

N'	→	N' /	V	N'	N'
total					total
					-

(T53') Total Deletion Rule III

N		N
human		human
unique		unique
root	→	root
definite		definite
associative		associative
plural		plural
total		

The last rule would have to be applied after the incorporation processes described, since 'total' is copied before it is deleted.

In section 1.2.3, it was stated that

(2.6.2.5.7) maragúl ya # iŋ patfŋ

is ambiguous, since it may mean:

*'The whale (a definite one) is big.'*

*'The whale (as a species) is big.'*

In its second meaning, where N is generic, the definite SUBJECT marker iŋ functions likewise as a generic indicator. Hence,  $\left[ \begin{array}{c} \text{generic} \\ \text{aggregate} \end{array} \right]$  is

replaced by [definite]. On the other hand, if N is  $\left[ \begin{array}{c} \text{generic} \\ \text{plural} \end{array} \right]$ , it is

replaced by  $\left[ \begin{array}{c} \text{plural} \\ \text{definite} \\ \text{demonstrative} \\ \text{proximate to hearer} \end{array} \right]$

(2.6.2.5.8) maragúl la # déŋ patfŋ

*'Those whales (near you) are big.'*

*'Whales (as a species) are big.'*

The relevant replacement rules may be formulated thus:

(T54') Generic Replacement Rule

$$\begin{array}{ccc}
 \begin{array}{c} \text{N} \\ \text{root} \\ \text{generic} \end{array} & \rightarrow & \begin{array}{c} \text{N} \\ \text{root} \end{array} \\
 \left\{ \begin{array}{c} [\text{aggregate}] \\ [\text{plural} \quad ] \end{array} \right\} \alpha & & \left[ \begin{array}{c} [\text{definite} \quad ] \\ \left[ \begin{array}{c} \text{plural} \\ \text{definite} \\ \text{demonstrative} \\ \text{proximate to hearer} \end{array} \right] \end{array} \right] \alpha
 \end{array}$$

## 2.7. LINEARISATIONS

### 2.7.1. Major Processes

The structures described thus far are essentially non-linear configurations, although the term 'extra-position' has been used in connection with the required context for subjectivisation. The term has been adopted merely as a convenient label; the structures up to this point of the derivation are still conceived of as non-linear (unless otherwise noted). The post-semantic processes thus far yield a non-linear semantic structure which may be represented thus (using a V with maximal specifications for accompanying N's):

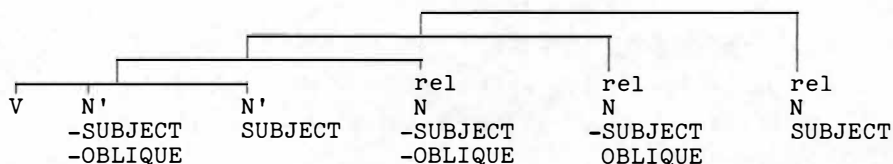

As a prelude to symbolisation, the whole structure must be linearised by a process to be labelled 'Primary Linearisation', following Chafe. As a notation for linear semantic structures, *rel* will no longer be indicated but only *V* and *N* (as well as *N'*). Hence, any configuration without *rel* is intended to be a linear (left to right) configuration. Besides Primary Linearisation, there will be three other types of major linearisation processes: Preposing, Post-posing (distinct from Extra-position), and Interposing. In a subsequent section, minor linearisation processes (linearisation within *V* and *N*) will be postulated.

#### 2.7.1.1. Primary Linearisation

The rule may be formulated thus:

(T55') Primary Linearisation Rule

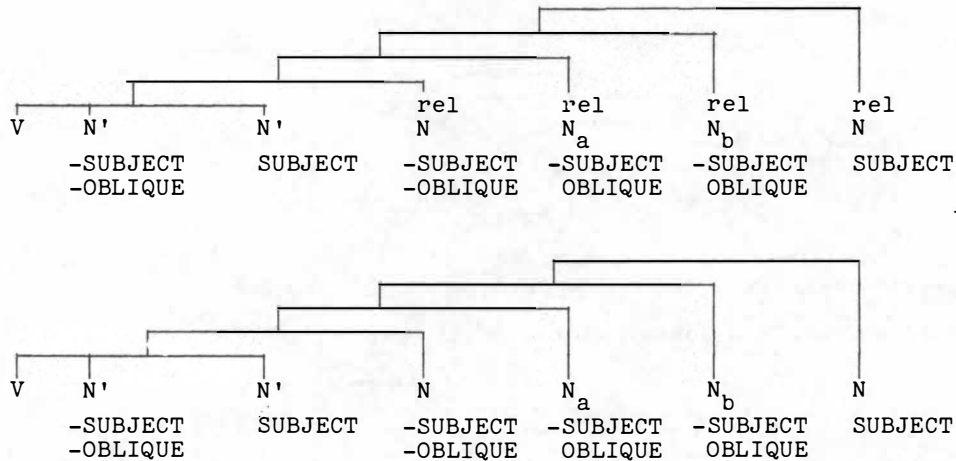

If no other major linearisation processes are applied, (T55') will yield such surface linear structures as:

(2.7.1.1.1)

babiyé ya # i Pédrú  
'Pedro is giving [something].'

pápabiyé ya kaŋ Suán # i Pédrú  
'Pedro is causing Juan to give [something].'

pápabiyé ya # kiŋ anák # kaŋ Suán # i Pédrú  
 'Pedro is causing Juan to give [something] to the child.'

papabiyé yaŋ kuáŋta # kiŋ anák # kaŋ Suán # i Pédrú  
 'Pedro is causing Juan to give money to the child.'

2.7.1.2. Post-Posing

Instead of the fourth sentence of (2.7.1.1), one may have:

(2.7.1.2.1')

pápabiyé yaŋ kuáŋta # kiŋ anák # i Pédrú # kaŋ Suán  
 'Pedro is causing money to be given to the child by Juan.'

The optional post-posing rule may be formulated thus:

(T56') OBLIQUE N Post-posing Rule I

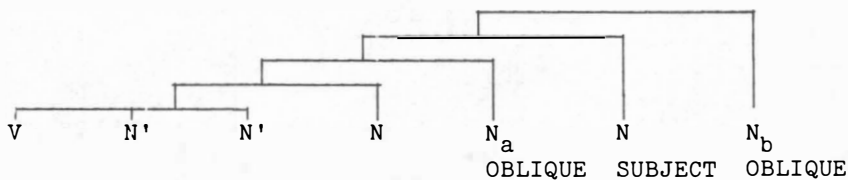
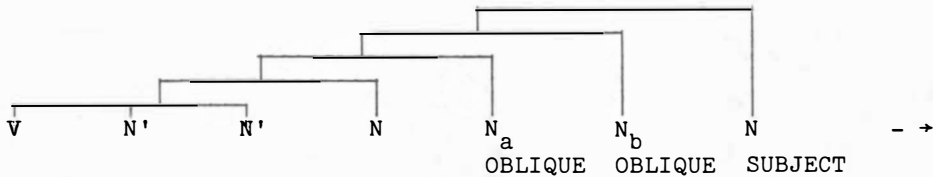

It is not only  $N_b$  which may be post-posed but likewise  $N_a$ . It seems, however, that if  $N_a$  is post-posed,  $N_b$  must likewise be post-posed:

(T57') OBLIQUE N Post-Posing Rule II

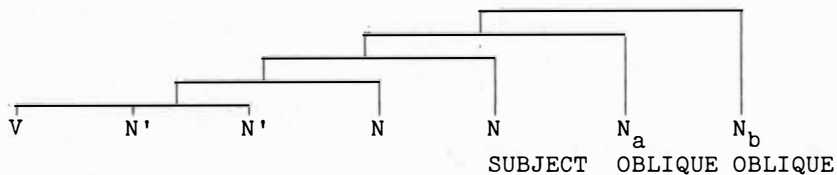
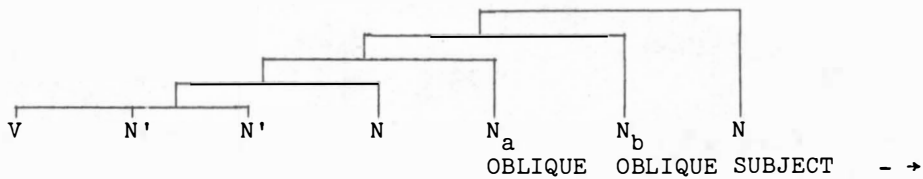

The above rule applies to a sentence with only one OBLIQUE N:

- (2.7.1.2.2) babiyé yaŋ kuáita # kiŋ anák # i Pédrú  
 babiyé yaŋ kuáita # i Pédrú # kiŋ anák  
 'Pedro is giving money to the child.'

### 2.7.1.3. Pre-Posing

In Pampangan, the main sentential accent falls on the initial phrase, which in sentences with unmarked linear order is V and any of its possible incorporations. It is possible, however, to highlight not V but one of the N's in the sentence. Such highlighting was labelled topicalisation in Chapter I (distinct from subjectivisation, which was discussed earlier in this Chapter). An N semantically specified as TOPIC must be pre-posed, to place it in the most prominent position in the sentence and to make it possible for the TOPIC N to receive the main sentential accent. Thus:

- (2.7.1.3.1) bíbiyé yaŋ kuáita # kiŋ anák # i Pédrú  
 'Pedro is giving money to the child.'
- (2.7.1.3.1a) i Pédrú # bíbiyé yaŋ kuáita # kiŋ anák  
 TOPIC  
 'As for Pedro, he is giving money to the child.'
- (2.7.1.3.1b) kiŋ anák ya bíbiyé kuáita # i Pédrú  
 TOPIC  
 'It is to the child that Pedro is giving money.'

When an OBLIQUE N is topicalised and pre-posed, it attracts to itself the copier (N'), in effect, deleting the boundary marker; moreover, it seems that in a sentence such as (2.7.1.3.1b), it is the whole initial phrase which receives sentential accent and not just anák.

As the rule for TOPIC specification has been formulated in Chapter I, kuáita cannot be topicalised since it is -definite. It is possible, however, to topicalise a -SUBJECT -OBLIQUE N, provided it is definite:

- (2.7.1.3.2) babiyé neŋ Pédrú # kiŋ anák # iŋ kuáita  
 'The money is being given to the child by Pedro.'
- (2.7.1.3.2a) i Pédrú # babiyé ne # kiŋ anák # iŋ kuáita  
 'As for Pedro, the money is being given by him to the child.'

Note, however, that when a -SUBJECT -OBLIQUE N is topicalised and fronted, determiner niŋ is replaced by determiner i, the SUBJECT determiner. In effect, sentence (2.7.1.3.2a) has two subjects, a primary subject, iŋ kuáita, and a secondary subject, i Pédrú, the latter a result of topicalisation and pre-posing.

The following rules need to be formulated for N's marked TOPIC:

(T58') TOPIC Pre-Posing Rule



(T59') N' Inter-posing Rule



(T60') Secondary Subjectivisation Rule

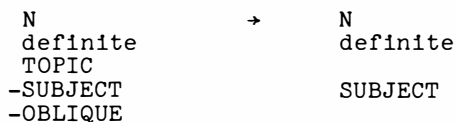

Pronouns may likewise be specified as TOPIC; if so specified, after the incorporation processes copying SUBJECT N and -SUBJECT -OBLIQUE N, the N matrix, instead of being deleted, is pre-posed and directly symbolised by the full SUBJECT form of the pronoun (in the symbolisation rules given, the form listed as occurring in the context ##\_\_):

(2.7.1.3.3) másakft ku # Ø

'I am sick.'

yáku # mäsakft ku

'As for me, I am sick.'

(2.7.1.3.4)\* b+in+iyáy ku ya # in librú >

biniyé ke # in librú

'The book was given to me.'

yáku # biniyé ke # in librú

'As for me, the book was given by me.'

OBLIQUE pronouns which are also TOPIC are pre-posed, attract the copier(s) to themselves and are symbolised by the usual oblique form of pronouns:

(2.7.1.3.5) biniyé neñ Pédrú # kanáku # in librú

'The book was given by Pedro to me.'

\* ka+n+áku na ya b+in+iyáy nañ Pédrú # in librú >

kanáku ne biniyé Pédrú # in librú

'It was to me that the book was given by Pedro.'

#### 2.7.1.4. Sentential Accent in Pampangan

The remarks on sentential accent that will be made in this section are tentative at best. They are based on the theory of generative phonology as a frame of reference and on what has been discovered so far concerning the acoustic correlates of accent (or stress) in non-tonal languages. More particularly, the hypotheses are based on a previous instrumental study of accent in Tagalog (see Gonzalez 1970), another Philippine language, closely related to Pampangan. Naturally, the hypotheses, where they have to do with acoustic correlates, would have to be confirmed by instrumental data, which unfortunately is unavailable for Pampangan at present. Still, the relevance of sentential accent to the material being discussed in the preceding section on pre-posing and topicalisation makes it worthwhile to at least essay some suggestions.

It has been observed that the ordinary intonation pattern of Tagalog sentences consists of an initial peak followed by descent. Since in both Tagalog and Pampangan, the nucleus of a sentence, V, is normally in initial position, the prominence given to initial position finds semantic justification. Bowen (1965:14) speaks of the 'descending stair-step pattern of Tagalog intonation' and Llamzon (1966) describes the intonation pattern of Tagalog statements as /221 ↓/ (using Trager and Smith notation). Gonzalez, using his own speech as data, confirmed this descending pattern instrumentally; it was discovered that after an initial peak, amplitude descended sharply although fundamental frequency remained more or less within the same range. Since, however, perceptual pitch is a function of both amplitude and fundamental frequency, Gonzalez' findings do not contradict the non-instrumental observations of either Bowen or Llamzon, although Bowen's postulation of a stair-step pattern

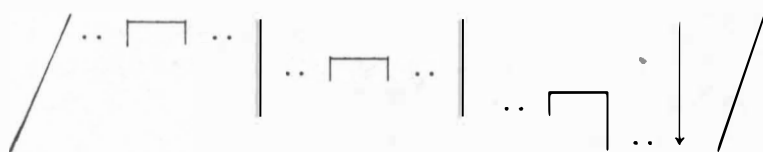

for longer sentences is perhaps a personal idiosyncrasy of his informants. What seems to be criterial is the initial peak followed by gradual descent, with the stages in this descent not significant. Hence, it would not do to consider the most common intonation pattern of Tagalog as the mirror-image of the rising terrace-level pattern of Acatlan Mixtec.

In Gonzales' study, however, the descending pattern was not found to obtain in the speech of a second informant, another native speaker.

In the data of the second informant, both amplitude and fundamental frequency remained more or less within the same range from the beginning of the sentence to the end, with naturally small peaks on the accented syllables. It would seem then that the descent is optional, perhaps a function of expressivity associated with new and -new information.

In general, the sound structure of Pampangan is almost identical with that of Tagalog. There are, of course, phonological differences between Tagalog and Pampangan, but the basic inventory of morphophonemes is identical.

Based solely on non-instrumental observation, I make the following hypotheses concerning accent in Pampangan: In a sentence such as

(2.7.1.4.1) mámaḡán yaḡ maís # i Pédru  
'Pedro is eating corn.'

all the accented vowels in morphophonemic representation begin with an initial value of 1 (acoustically, if the correlates of accent in Pampangan are the same as the correlates of accent in Tagalog, the vowel of accented syllables has a higher frequency, greater amplitude, and longer duration than a non-accented vowel). Thus:

mámaḡán yaḡ maís # i Pédru  
1 1 1 1

There is need for a phonological rule reducing value 1 to 2 for all accented vowels which are not the loci for the main accent of a polysyllabic word. Usually, this main accent falls on the root:

mámaḡán yaḡ maís # i Pédru  
2 1 2 1

There is likewise a noticeable lengthening of initial ma- [ ma: ]  
2

which is predictable and which would have to be noted in a less broad transcription. Unlike English, Pampangan phrases do not rise to a peak syllable. Hence, there seems to be no need to postulate a further phonological rule to reduce values of 2 to 3. In general, the intonation pattern of an all-new Pampangan sentence would be:

#

This relative uniformity (with accented syllables naturally forming minor crests) plus the lack of vowel reduction and well-nigh uniform CV - syllable structure of the language is doubtless responsible for the impression that it is a 'syllable-timed' language, for the preceding features give an impression of uniformity, although Gonzalez' instrument-measures data for Tagalog belies any claim to a uniform syllable duration for Tagalog (and presumably for Pampangan). The descending pattern

must still be accounted for, since it is quite common. It would seem that the descent occurs in phrases which are -new; these phrases are likewise candidates for deletion. Thus, if the subject N of the example is -new, an optional reduction to 3 of all accented vowels in the -new phrase may be postulated:

-new  
 mámaḡán yaḡ maís i Pédrú  
 2 1 1 3

This would give rise to a descending step-pattern:

\_\_\_\_\_ # \_\_\_\_\_

I shall hypothesise further that what may be contained in the first

part of the sentence may not only be V or  $\overline{V}$  N but even  $\overline{V}$   $\overline{N}$   $\overline{N}$   $\overline{N}$ , provided these N's are marked new. Where the N's are marked -new, the descent begins. Hence, the general intonation pattern of a sentence such as:

(2.7.1.4.2) babiyé yaḡ kuáita # kiḡ anák # i Pédrú  
 'Pedro is giving money to the child.'

would be

\_\_\_\_\_ # \_\_\_\_\_ # \_\_\_\_\_

It is interesting to note that when N is TOPIC and pre-posed, the peak occurs initially and there is usually a sharp descent after the TOPIC N:

(2.7.1.4.2a) i Pédrú # babiyé yaḡ kuáita # kiḡ anák  
 'As for Pedro, he is giving money to the child.'

When the topicalised N is OBLIQUE, it seems that the descent does not begin until after the first pause, since the OBLIQUE N has been incorporated into the verb phrase:

(2.7.1.4.2b) kiḡ anák ya babiyé kuáita # i Pédrú  
 'It is to the child that Pedro is giving money.'

The descent (or reduction to value 3) is optional, since if the descent does not occur, communication is not impaired, although its non-occurrence in -new phrases would seem unusual to a native speaker.

## 2.7.2. Minor Linearisation Processes

Sequential to the major linearisation processes described in section 2.7.1. will be minor linearisation processes involving V and each one of the accompanying N's.

## 2.7.2.1. Linearisation of V

The first linearisation process separates negative (if it occurs) from the rest of the V matrix: V is replaced by  $\overbrace{\text{negative V}}^{\text{root}}$

root  
 y  
 negative

root  
 y

Moreover, like the pre-posed OBLIQUE N which is topicalised, negative attracts the copiers to itself so that an interposing process would have to be postulated to account for:

- (2.7.2.1.1)      lálákad ya # i Pédru 'Pedro is walking.'  
                   é ya lálákad    # i Pédru 'Pedro is not walking.'

If V has more than one copier, then both copiers must be interposed between the negative and the verb root:

- (2.7.2.1.2)      biniyé ne niḡ anák # iḡ áutu  
                   é ne biniyé    niḡ anák # iḡ áutu  
                                   'The car was given by the child.'  
                                   'The car was not given by the child.'

The usual symbolisation for 'negative' is tonic é. However, the symbolisation for the expression 'No' is aíf. And when the verb root is deleted, the symbolisation for 'not' is likewise aíf: aíf ya 'He is not' instead of \*é ya. The two forms are most likely from a Proto-Pampangan form \*aíf > aíf > é. It is not uncommon for Proto-Austronesian \*l to become y and eventually Ø in Pampangan. The ai > e shift is a current phonological rule.

After negative specification has been linearised into a separate sub-branch, there will be need of a rule linearising V further into

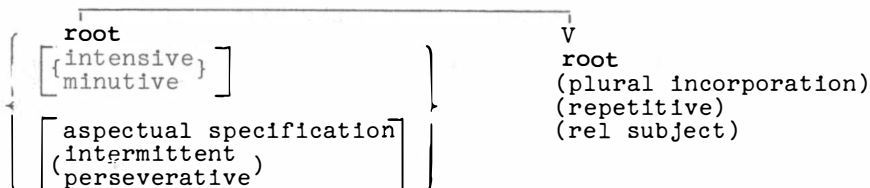

At this point in the derivation, the deletion processes have already applied; hence, it is possible for the incorporated rel subject to have been deleted. In a pedagogical grammar, it will perhaps be more economical to symbolise

$\left[ \begin{array}{l} \text{V} \\ \text{root} \\ \text{(plural)} \\ \text{(repetitive)} \\ \text{(rel subject)} \end{array} \right]$

directly since the final linearis-

ation of V (root and inflectional specifications) is erratic, although the agglutination is relatively transparent once the sequence is known.

A general pattern of verb root linearisation is

PREFIX	INFIX	ROOT	SUFFIX
--------	-------	------	--------

Incorporated plural, symbolised by *-ŋa-* is always an infix; if there is no prefix, \**mag-* is used, as in: *lákad* 'walk' \**mag+ŋa+lákad* > *maŋlákad* 'to walk repeatedly'. While rel subject is often  $\emptyset$  in unmarked configurations, if extra-position has taken place, rel subject is overtly symbolised. The marker for rel subject may be a prefix (e.g. *i-*) or a suffix (e.g. *-an*) or a discontinuous morph (e.g., *ka-...-an*). In the latter case, some type of 'affix-hopping rule' would have to be formulated as part of the symbolisation process: \**ka-...-an+matáy* → *kamatáyan*.

In terms of the theory, 'zero morphs' (semantic units which receive no symbolisation), to use the terminology of American structural linguistics, do not arise, since they are post-semantically deleted before symbolisation takes place. So called 'portmanteau morphs' are directly symbolised as matrices of semantic units (determiners, counters, measures, copiers, non-lexically specified N's which are not deleted). It is 'carriers' such as \**mag-* in *maŋlákad* which give rise to 'empty morphs' (symbolisations with no correlative semantic unit).

The remaining units (aspectual specifications, intensive, minutive, perseverative, intermittent) pre-suppose that the root with its affixes has already been symbolised before their own symbolisation can take place. Aspect is symbolised in Pampangan by various processes: accental shift, infixing, suffixing, reduplication, or a combination of these. The other specifications are symbolised by various types of reduplications. Hence, another symbolisation process of the following type must be posited:

aspectual	+ symbolised root	→	XXX
specifications	with affixes		

For example:

durative	+ <i>maŋlákad</i>	→	<i>máŋlákad</i>
----------	-------------------	---	-----------------

Still a third stage of symbolisation must be posited if the output of the above rule is specified as intensive/minutive (for state V's) or intermittent/perseverative (for -state V's). The latter specifications pre-suppose symbolisation of V for root and for aspect and use this symbolisation as input. Thus:

$$\left\{ \begin{array}{l} \{ \text{intensive,} \\ \text{minutive} \} \\ \text{intermittent} \\ \text{perseverative} \end{array} \right\} + \left[ \begin{array}{l} \text{symbolised root} \\ \text{symbolised aspect} \end{array} \right] \rightarrow \text{YYY}$$

For example:

intermittent + maḡlákad → maḡ+laká+lákad

The following linearisation processes for V must be posited:

(T61') V Linearisation Rule I

$$\begin{array}{l} \text{V} \\ \text{root} \end{array} \rightarrow \left\{ \begin{array}{l} \{ \text{intensive,} \\ \text{minutive} \} \\ \text{repetitive} \\ \text{intermittent} \\ \text{perseverative} \end{array} \right\}$$

(aspectual specifications)  
 (negative)  
 (incorporated) plural  
 (incorporated) rel subject

(negative)	$\left\{ \begin{array}{l} \{ \text{intensive,} \\ \text{minutive} \} \\ \text{intermittent} \\ \text{perseverative} \end{array} \right\}$	(aspectual specifications)	V
			root
			(plural)
			(repetitive)
			(rel subject)

(T62') V Linearisation Rule II

$$\begin{array}{l} \text{V} \\ \text{root} \\ \text{(plural/repetitive)} \\ \text{(rel subject)} \end{array} \rightarrow$$

PREFIX	INFIX	ROOT	SUFFIX
--------	-------	------	--------

The last rule is intended only as a general statement since various roots manifest idiosyncratic properties of linearisation based on their constituent roots (basic or derived) and affixes. For purposes of analysis, linearisations of the above type would be useful; for pedagogical purposes, however, it is perhaps more economical to by-pass (T62') and symbolise its input directly. For V's inflected as negative, there is a further linearising rule necessary:

## (T63') Negative Inter-posing Rule

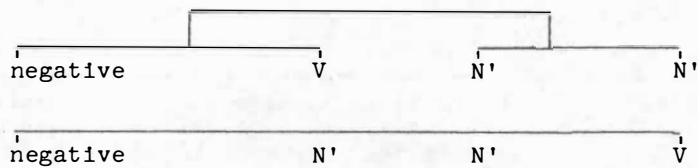

## Symbolisation of Aspect

The symbolisations of the different aspectual inflections vary according as V is a basic root or V is accompanied by affixes. A table of the type set down in Table II would have to be consulted for the symbolisation of aspect:

TABLE II:  
Verb Inflection Aspectual Paradigms

	Aspect 1: actual	Aspect 2: actual completed	Aspect 3: actual durative generic	Aspect 4: actual completed immediate
ROOT CV(C)CVC lákad 'to walk' ladiád 'to lay out'	C+um+V(C)CVC lumákad lumadiád	C+in+V(C)CVC línákad línadiád	CV+CV(C)CVC lálákad láladiád	ka+(root) <sup>2</sup> kalákadlákad kaladiádladiád
VCVC urán 'rain'	m+VCVC murán	m+in+CVC minurán	m+V+m+VCVC múmurán	ka+(root) <sup>2</sup> kauránurán
VC í? 'urine'	m+VC mí?	m+inVC mini?	m+V+m+VC mímfí?	ka+(root) <sup>2</sup> *ka+í?+í?>kai?
PREFIX (ES)+ROOT a(ka)+CV(C)CVC asúlat 'write' akasúlat	a(ka)+CV(C)CVC ásúlat ákasúlat	a(ka)+CV(C)CVC ásúlat ákasúlat	a+CV+CV(C)CVC a+ka+ka+CV(C)CVC ásusúlat ákakasúlat	
i+CV(C)CVC isúlat	i+CV(C)CVC isúlat	C+in+V(C)CVC sinúlat	CV+CV(C)CVC súsúlat	
ma(ka)+ maki+ maŋ+CV(C)CVC ma(ŋa)+ maŋapa+ man+ mag(pa)+ magiŋ+ magiŋmarók 'to turn bad'	ma(ka)+ maki+ maŋ+CV(C)CVC ma(ŋa)+ maŋapa+ man+ mag(pa)+ magiŋ+ magiŋmarók	me(ka)+ meki+ meŋ+CV(C)CVC me(ŋa)+ meŋapa+ men+ {migi(pa)+ } {meg+ } megiŋ+ mégiŋmarók	ma(ka)+ maki+ maŋ+CV(C)CVC ma(ŋa)+ maŋapa+ man+ mag(pa)+ magiŋ+ mágiŋmarók	

Table II Cont'd:

	Aspect 1: actual	Aspect 2: actual completed	Aspect 3: actual durative generic	Aspect 4: actual completed immediate
<p>ROOT+SUFFIX</p> <p>CV(C)CVC+an(an)</p> <p>sukatánan 'write'</p>	<p>CV(C)CVC+anan CV(C)CVC+an</p> <p>sulatánan</p>	<p>C{<sup>i</sup><sub>e</sub>}(C)CVC+anan C{<sup>i</sup><sub>e</sub>}(C)CVC+an</p> <p>sílatánan</p>	<p>CV+CV(C)CVC+anan CV+CV(C)CVC+an</p> <p>susulatánan</p>	
<p>PREFIX+ROOT+SUFFIX</p> <p>ma+CV(C)CVC+(an)</p> <p>malakáran 'walk'</p>	<p>ma+CV(C)CVC+an ma+CV(C)CVC</p> <p>malakáran</p>	<p>m{<sup>i</sup><sub>e</sub>}(C)CVC+an m{<sup>i</sup><sub>e</sub>}(C)CVC</p> <p>mélakáran</p>	<p>ma+CV(C)CVC+an ma+CV(C)CVC ma-</p> <p>malalakáran</p>	
<p>mipag+CV(C)+CVC+(an)</p> <p>mipa+</p> <p>mipaglabánan 'fight'</p>	<p>mipag+CV(C)CVC +an mipa+CV(C)CVC mipaglabánan</p>	<p>mipag+CV(C)CVC +an mipa+CV(C)CVC mípaglabánan</p>	<p>mipag+CV(C)CVC+an mipa+CV(C)CVC mipáglabánan</p>	
<p>pa+</p> <p>paka+</p> <p>paki+CV(C)CVC+(an)</p> <p>ipaŋ+</p> <p>ipant+</p> <p>*ipant+súlat 'write'</p>	<p>pa+</p> <p>paka+CV(C)CVC+an paki+CV(C)CVC ipaŋ+</p> <p>ipant+</p> <p>ipanyúlat</p>	<p>pepa+</p> <p>peka+CV(C)CVC+an peki+CV(C)CVC peŋ+</p> <p>pent+</p> <p>pényúlat</p>	<p>papa+</p> <p>paka+CV(C)CVC+an paki+CV(C)CVC paŋ+</p> <p>pan+</p> <p>pányúlat</p>	
<p>pipag+CV(C)CVC+(an)</p> <p>pipagsulátan 'write'</p>	<p>pipag+CV(C)CVC +an pipag+CV(C)CVC pipagsulátan</p>	<p>pipag+CV(C)CVC +an pipag+CV(C)CVC pípagsulátan</p>	<p>pipag+CV(C)CVC+an pipag+CV(C)CVC pipágsulátan</p>	

## 2.7.2.2. Linearisation of N

Consider the sentence:

(2.7.2.2.1) *mátudtúd lanán # détlń sablńń ának a réti*  
*'Each and all of these children (near you and me)*  
*are sleeping.'*

where the child is N which must be linearised by a  
 'child'  
 plural  
 definite  
 demonstrative  
 proximate to speaker  
 proximate to hearer  
 total  
 individuated  
 SUBJECT

minor process into

D a	D b	N
plural	total	'child'
definite	individuated	plural
demonstrative		
proximate to speaker		
proximate to hearer		
SUBJECT		

where D is a convenient label for determiner (the subdivision into two types, a and b, is rendered necessary because of other processes that will be described subsequently). Note that the unit 'plural' is not transferred into Da but is copied into Da. This retention of 'plural' in N seems to be a property of particular lexical roots, in this case, 'child': *anáń* 'child' *ának* 'children'. Other roots do not retain the plural specification. Moreover, whenever N is inflectionally specified as demonstrative, there is an optional copying process:

D a	D a '
plural	plural
definite	definite
demonstrative	demonstrative
proximate to speaker	proximate to speaker
proximate to hearer	proximate to hearer
SUBJECT	SUBJECT

It is not clear whether this copying process (an instance of re-duplication of a certain type) adds meaning; perhaps the re-duplication emphasises the unit 'demonstrative'. In my idiolect, it seems that the re-duplication adds no new meaning. Conceivably, it could. This would mean that the unit 'demonstrative' may be further specified as 'emphatic'. The context then for the copying process

outlined above would be the unit 'emphatic'. After Da has been copied, its copier, Da ', must be post-posed. Hence, the surface sub-structure of the subject phrase of sentence (2.7.2.2.1) would be:

D a	D b	N	D a '
plural	total	plural	plural
definite	individuated		definite
demonstrative			demonstrative
proximate to speaker			proximate to speaker
proximate to hearer			proximate to hearer
SUBJECT			SUBJECT
*dėti+η	sabla?+η	ának a	dėti

In such instances, after the linearisation of N, there has to be another inter-posing process placing 'two' in the position between D a and N:

D a	V	N	D a '
plural	'two'	'child'	plural
definite		plural	definite
demonstrative			demonstrative
proximate to speaker			proximate to speaker
proximate to hearer			proximate to hearer
SUBJECT			SUBJECT

N, if -definite, can be both quantitative and partitive:

(2.7.2.2.3) ménaη yaη aduá kariη dalandán # i Pédrú  
'Pedro ate two of the oranges.'

in which the patient N is N . The semantic sub-structure

plural  
quantitative  
numerical  
two  
partitive

may be represented thus:

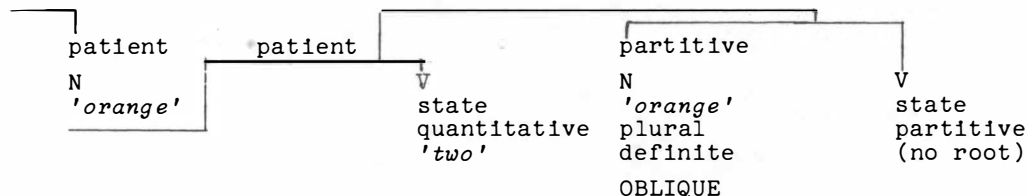

A variant (actually the preferred one) of (2.7.2.2.1) is:

(2.7.2.2.1') mátuđtúđ laηán # diη sablań anak a réti

It would seem then that the copying process for demonstratives has a variant output:

	- →		
D a		D a	D a '
plural		plural	plural
definite		definite	definite
demonstrative			demonstrative
proximate to speaker			proximate to speaker
proximate to hearer			proximate to hearer
SUBJECT		SUBJECT	SUBJECT

Consider now the sentence:

(2.7.2.2.2) máttudtúð ía # détiŋ aduáŋ ának a réti  
*'These two children (near you and me) are sleeping.'*

It was shown in Chapter I that when N is specified as quantitative (estimateive or numerical), the structure of N is replaced by:

patient		patient
N		V
'child'		state
plural		quantitative
definite		numerical
demonstrative		'two'
proximate to speaker		
proximate to hearer		
SUBJECT		

Since 'orange' is repeated, one of the occurrences is -new. In partitive matrices, it seems that it is the unit to the left which is deleted; moreover, since the partitive state V is without lexical specification, it is likewise deleted, leaving only a  $\overline{V}$  N structure. After N has been linearised, the surface sub-structure is:

V		D		N
'two'		plural		'orange'
		definite		
		OBLIQUE		
*aduá?		ka+díŋ		dalandán

N may likewise be inflectionally specified for counters or measures, as in:

(2.7.2.2.4) kinuá na íaŋ Pédrú # díŋ aduáŋ píliŋ a ságin  
*'The two bunches of bananas were taken by Pédrú.'*

The subject N may be characterised thus:

N  
 clustered  
 twisted off  
  
 counter  
 indefinite  
 plural  
 definite  
 quantitative  
 numerical  
 two  
 SUBJECT

The matrix must first be linearised thus:

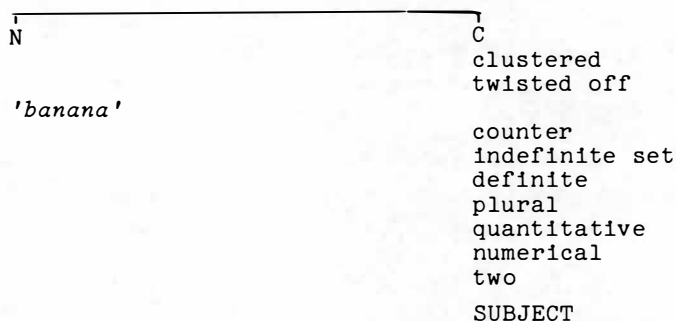

C post-semantically behaves as an ordinary N. It must be replaced by:

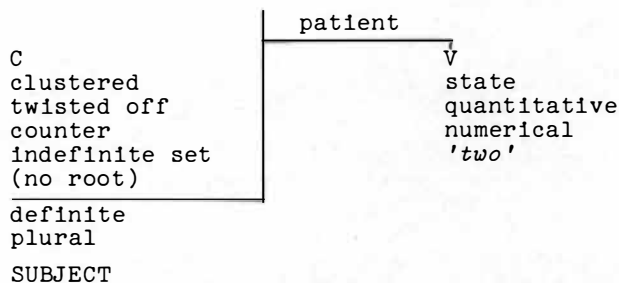

The usual processes for quantitative N's are then applied; in surface sub-structure, N is post-posed; 'two' is inter-posed between the subject determiner and the classifier:

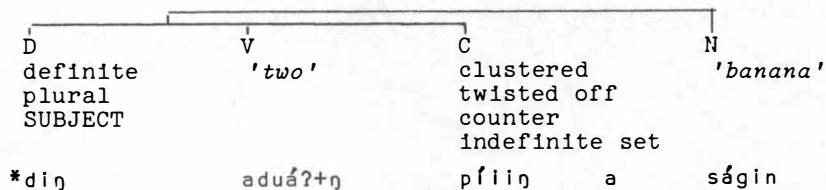

As with verb roots, there will be need of a further linearisation process for noun roots:

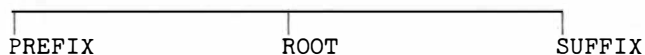

The root itself, of course, may be a derived root, composed of several basic roots or a re-duplicated root. Again, as with verbs, in the symbolisation process, there will be need for an 'affix-hopping rule' as in:

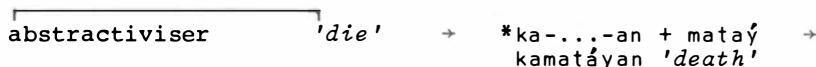

In general, infixes do not occur in noun roots, unless of course one considers a prefix to which is added still another prefix as a kind of infix. Hence, in the linearisation of the noun root set down above, INFIX is not included.

The minor linearisation processes for N may be formulated thus (it is assumed that the numerical state V and the partitive state V which may accompany N are generated by the semantic rules):

(T64') Noun Root Deletion Rule for Partitive

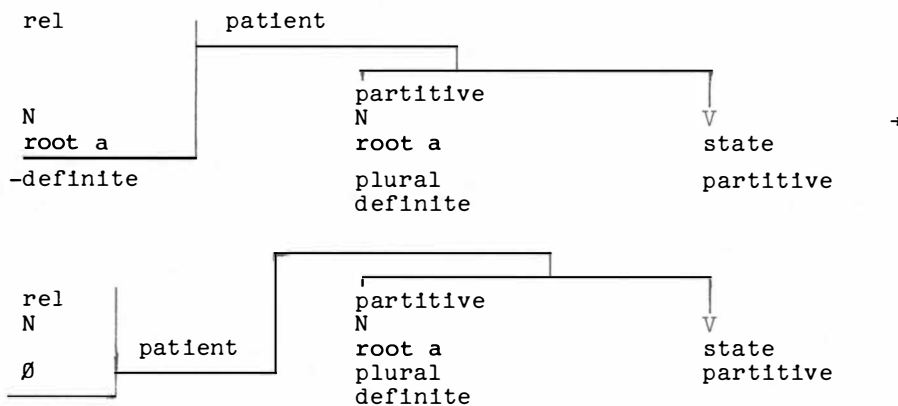

(Eventually, both  $\overset{\text{rel}}{N}$  and  $V$  state partitive are deleted, but such branch

deletions of V and N have already been formulated.)

(T65') C Linearisation Rule I

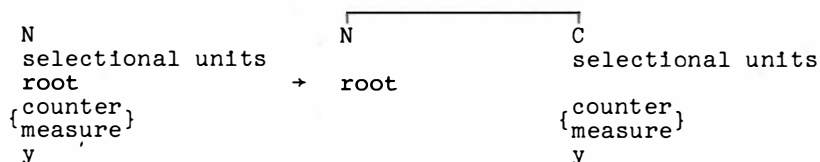

where selectional units = units not deleted by the process deleting selectional units; for classifiers, these include criterial units such as '*sliceable*', '*human*', '*twisted off*', and the like; y = inflectional units which have not been deleted by previous processes

## (T66') C Linearisation Rule II

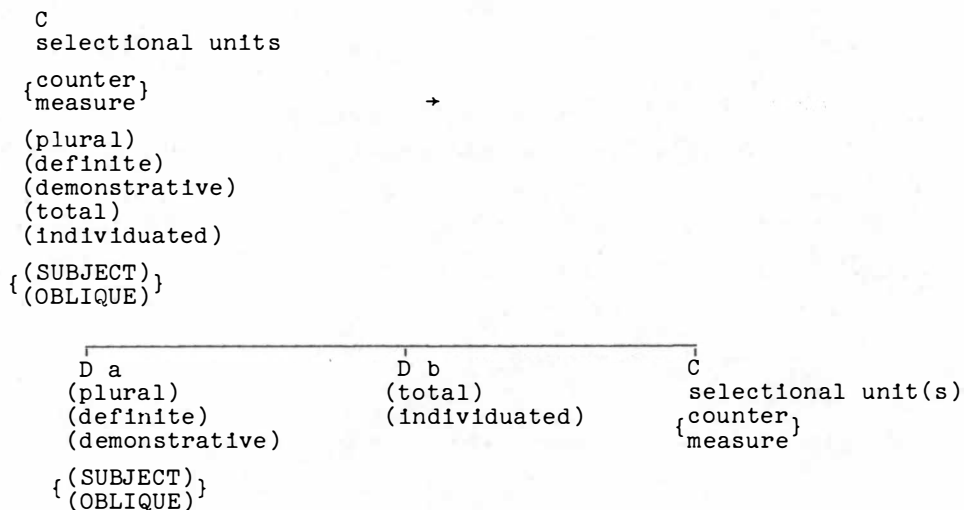

## (T67') N Linearisation Rule

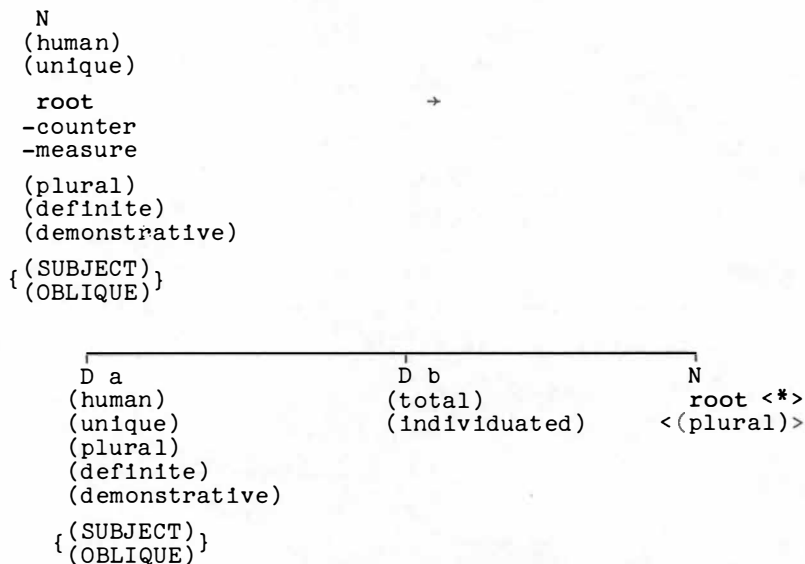

where root \* indicates a subset of roots which retain plural

## (T68') Demonstrative Copying Rule

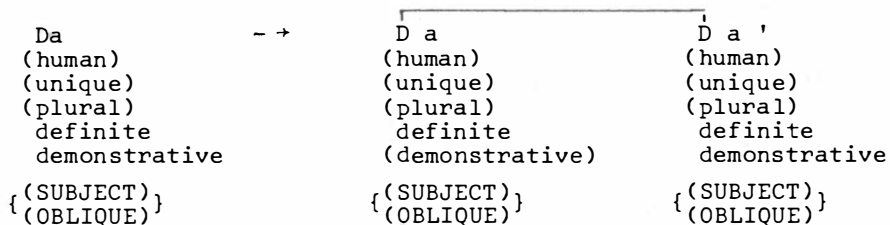

(Certain of the units listed in parentheses in T66' and T67' are mutually exclusive; the earlier semantic rules with their restrictions will prevent their occurrence. The rule is merely intended to show how units will be linearised; not all the units listed occur at once.)

## (T69') Demonstrative Copier Post-posing Rule

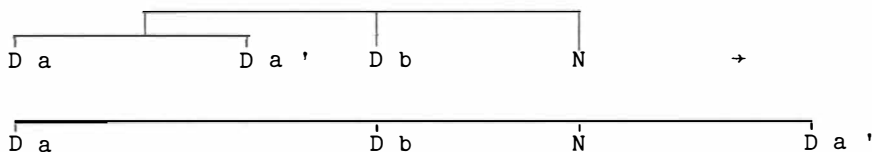

## (T70') Number Inter-posing Rule

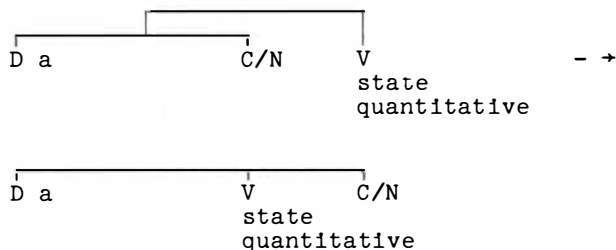

(The rule is optional since one can give *dij anak a adua?* 'the two children' as well as *dij aduañ anak*; *dij pflin a ságin a adua?* 'the two bunches of bananas' as well as *dij aduañ pflin a ságin*.)

## (T71') Noun Root Linearisation Rule

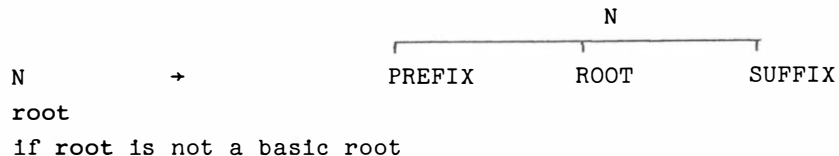

## 2.8. SUMMARY

In this section, the rules formulated in sections 2.1 to 2.7 will be set down successively, with the revisions and the re-ordering suggested by the topics discussed. These rules will then be applied to the post-semantic derivation of the semantic structure generated at the conclusion of Chapter I to show how the rules apply.

## 2.8.1. Re-statement of Rules

(The numbering of the rules in this section supersedes that of previous sections; in the derivation of the sentence in the sentence following, this numbering will be followed.)

## (T1) Extra-position Rule I

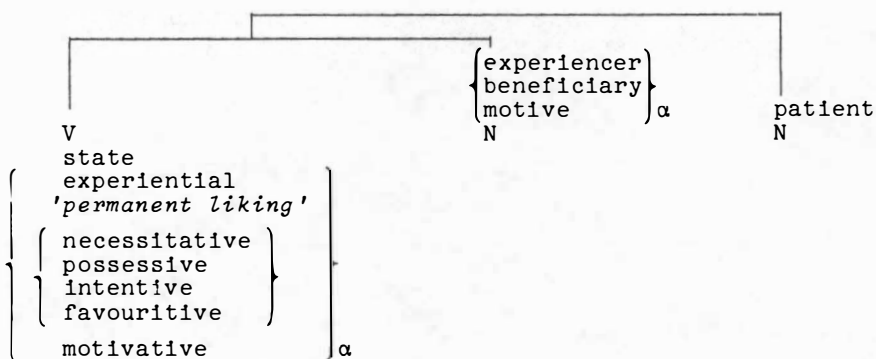
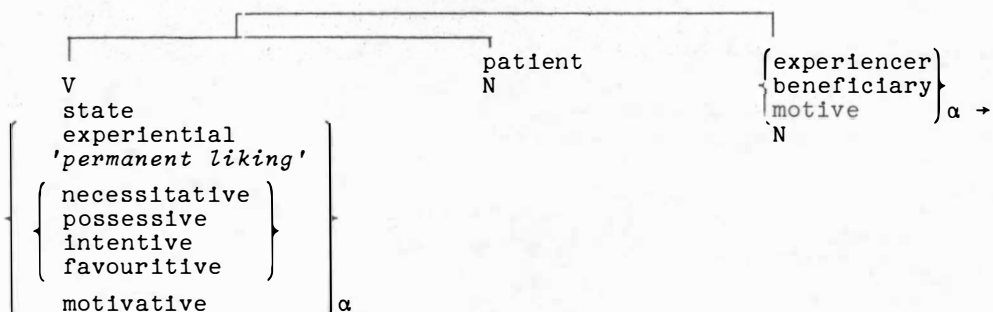

## Extra-position Rule II

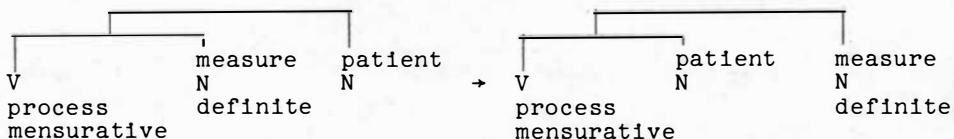

Extra-position Rule III

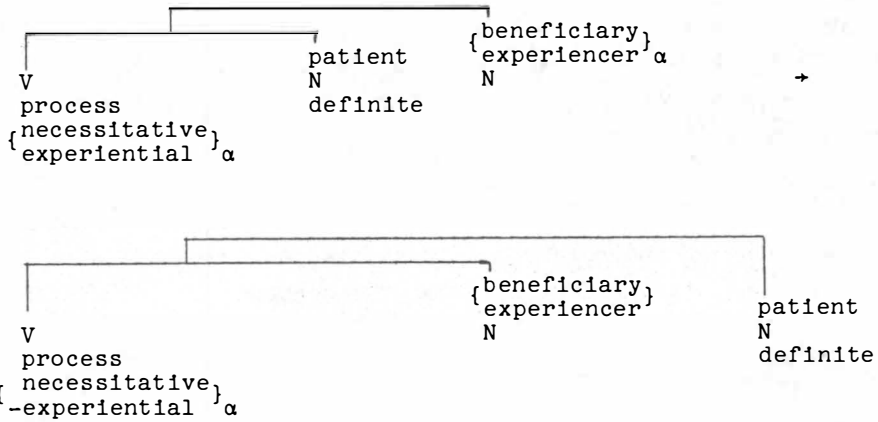

Extra-position Rule IV

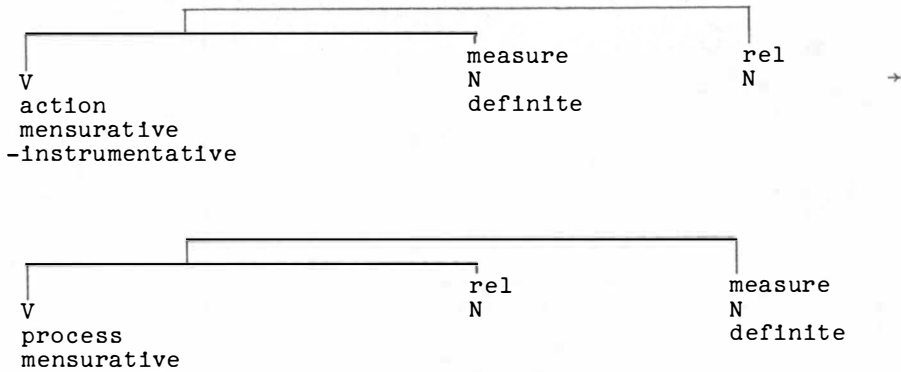

Extra-position Rule V

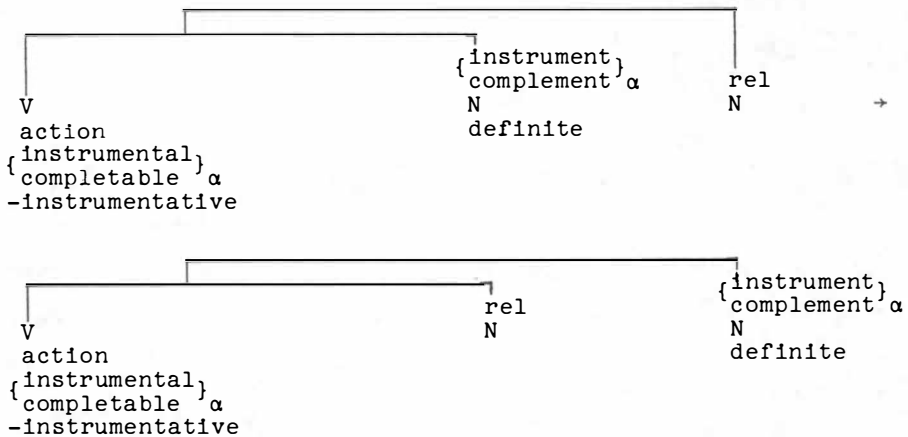

Extra-position Rule VI

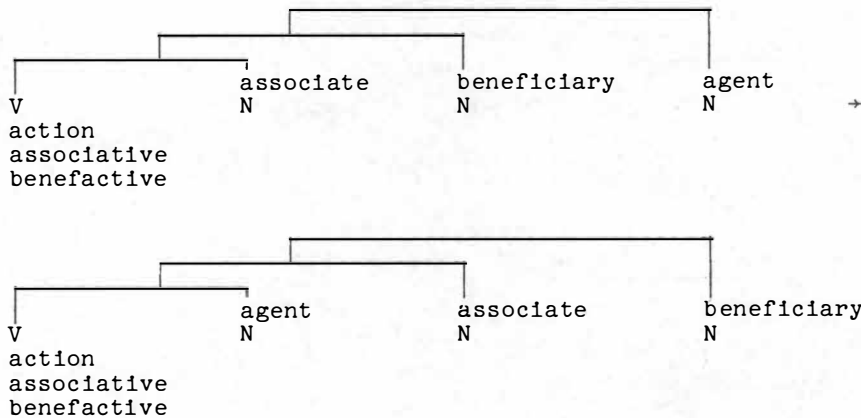

Extra-position Rule VII

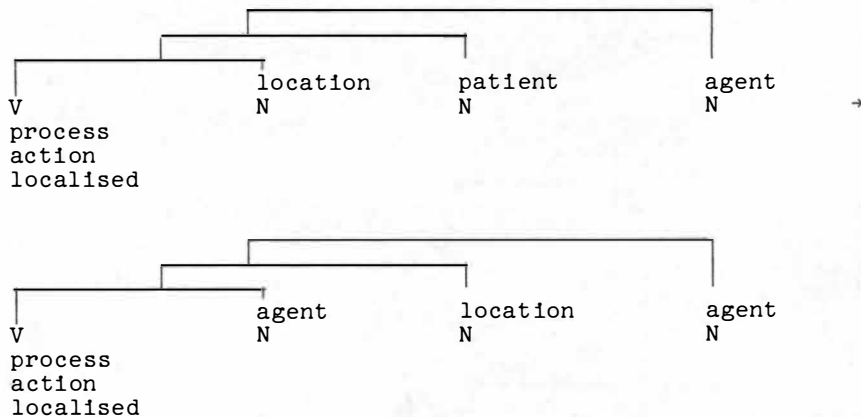

The next rule applies only if (T1) has not applied

(T2) Extra-position Rule I (for -new N)

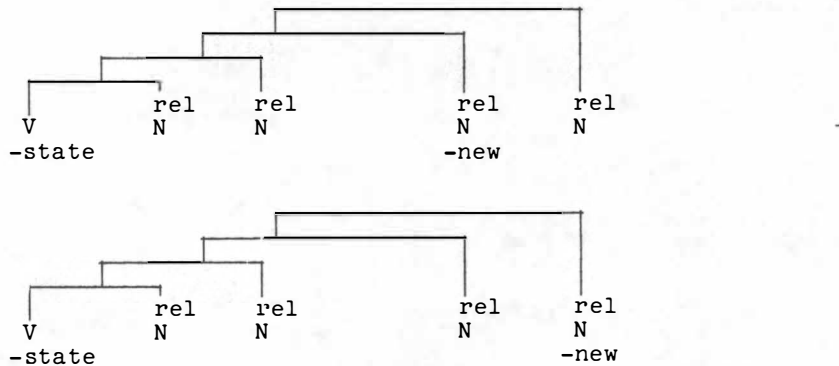

Extra-position Rule II (for -new N)

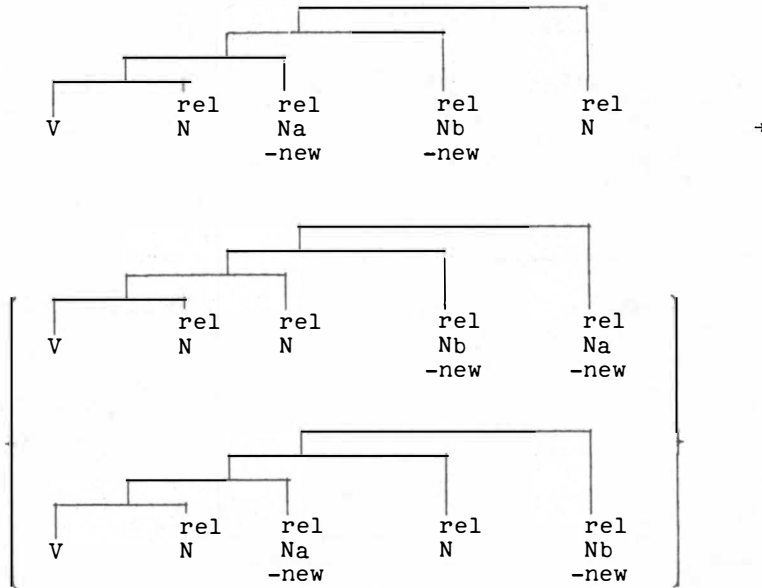

(T3) Reflexive Rule

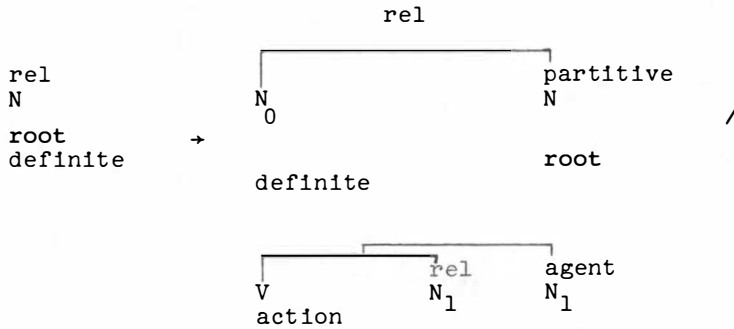

(T4) Subjectivisation Rule

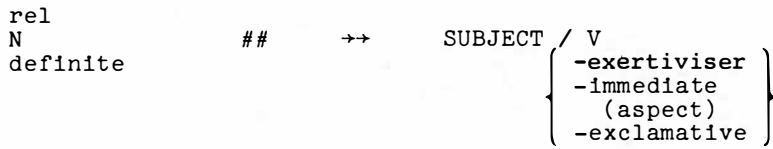

where ## means outermost or extra-posed N

(T5) Subject Incorporation Rule

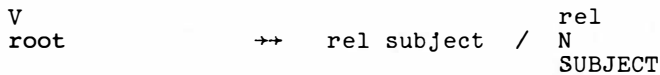

## (T6) Syncretisation Rule

agentive beneficiary beneficiary motive norm associate partitive material source goal location time N	→→	OBLIQUE
--	----	---------

## (T7) OBLIQUE to -OBLIQUE Shift Rule I

{motive beneficiary norm N OBLIQUE}	→	{motive beneficiary norm N -OBLIQUE}	/	V {due to needing equatativiser similaritativiser}
---	---	--	---	--

## OBLIQUE to -OBLIQUE Shift Rule II

beneficiary N OBLIQUE	- →	beneficiary N -OBLIQUE	/	<table style="border-collapse: collapse; margin: auto;"> <tr><td style="border-top: 1px solid black; border-bottom: 1px solid black; padding: 0 5px;">N</td><td style="border-top: 1px solid black; border-bottom: 1px solid black; padding: 0 5px;">N</td></tr> <tr><td style="padding: 0 5px;">beneficiary</td><td style="padding: 0 5px;">beneficiary</td></tr> </table>	N	N	beneficiary	beneficiary
N	N							
beneficiary	beneficiary							
partitive N OBLIQUE	→	partitive N -OBLIQUE	/	<table style="border-collapse: collapse; margin: auto;"> <tr><td style="border-top: 1px solid black; border-bottom: 1px solid black; padding: 0 5px;">N</td><td style="border-top: 1px solid black; border-bottom: 1px solid black; padding: 0 5px;">N</td></tr> <tr><td style="padding: 0 5px;">partitive</td><td style="padding: 0 5px;">partitive</td></tr> </table>	N	N	partitive	partitive
N	N							
partitive	partitive							

## (T8) -OBLIQUE to OBLIQUE Shift Rule

{patient agent N -SUBJECT -OBLIQUE}	→	{patient agent N -SUBJECT OBLIQUE}	/	V {state motivativiser action non-active abilitativiser}
---	---	--	---	--

## (T9) SUBJECT Incorporation Rule Ia

<table style="border-collapse: collapse;"> <tr><td style="border-top: 1px solid black; border-bottom: 1px solid black; padding: 0 5px;">V</td><td style="border-top: 1px solid black; border-bottom: 1px solid black; padding: 0 5px;">rel</td></tr> <tr><td style="padding: 0 5px;"></td><td style="padding: 0 5px;">N</td></tr> </table>	V	rel		N	→	<table style="border-collapse: collapse;"> <tr><td style="border-top: 1px solid black; border-bottom: 1px solid black; padding: 0 5px;">V</td><td style="border-top: 1px solid black; border-bottom: 1px solid black; padding: 0 5px;">N'</td><td style="border-top: 1px solid black; border-bottom: 1px solid black; padding: 0 5px;">rel</td></tr> <tr><td style="padding: 0 5px;"></td><td style="padding: 0 5px;"></td><td style="padding: 0 5px;">N</td></tr> </table>	V	N'	rel			N
V	rel											
	N											
V	N'	rel										
		N										
-abstract count root (plural) (total) SUBJECT		(plural) (total) SUBJECT	/	-abstract count root (plural) (total) SUBJECT								

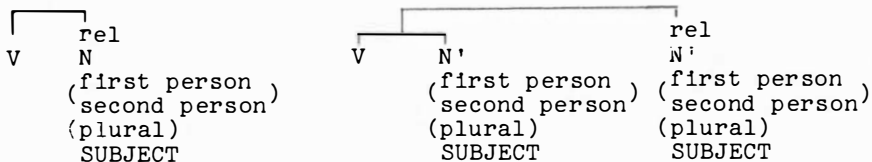

SUBJECT Incorporation Rule II

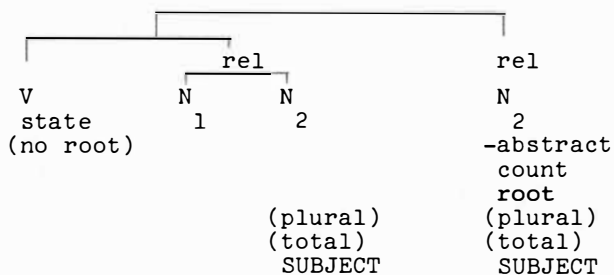
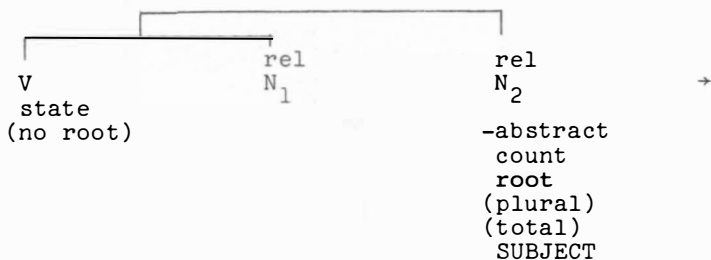

{T10} -SUBJECT -OBLIQUE Incorporation Rule Ia

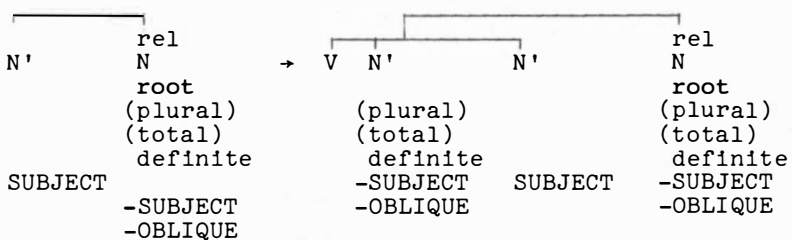

-SUBJECT -OBLIQUE Incorporation Rule Ib

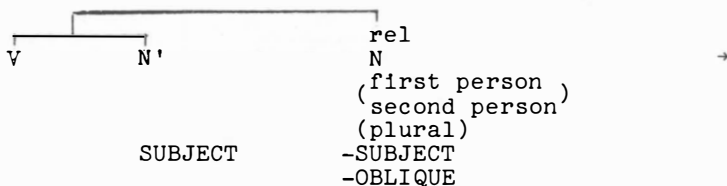

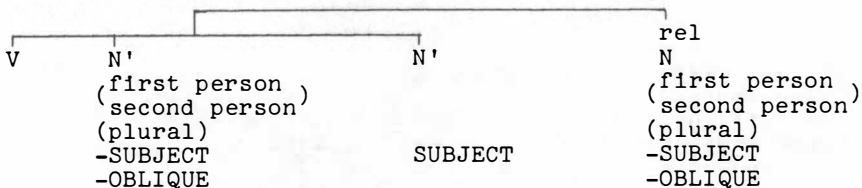

-SUBJECT -OBLIQUE Incorporation Rule IIa

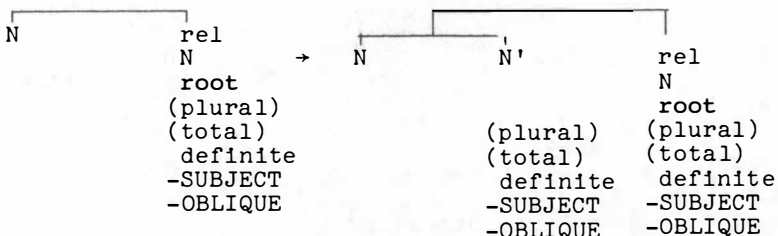

-SUBJECT -OBLIQUE Incorporation Rule IIb

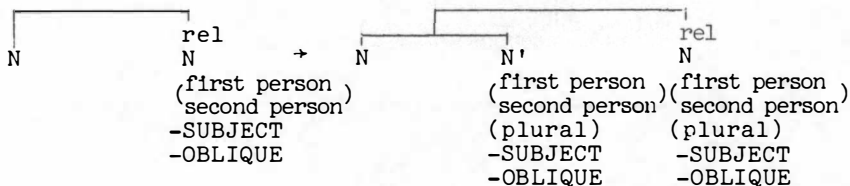

(T11) OBLIQUE Incorporation Rule

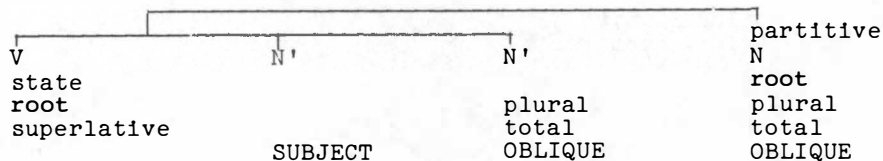
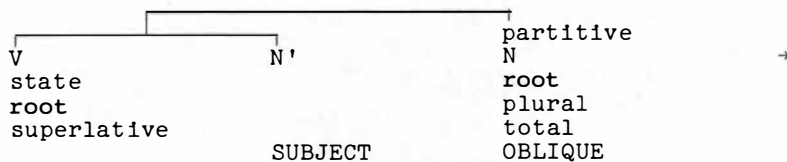

## (T12) Plural Incorporation Rule

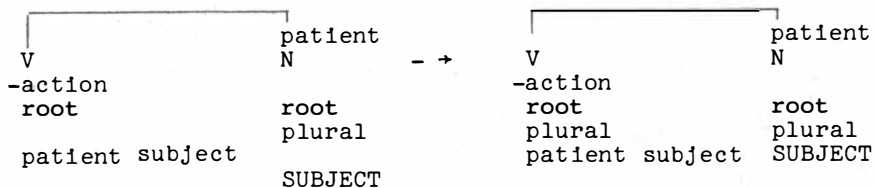

## (T13) First Person Plural Neutralisation Rule

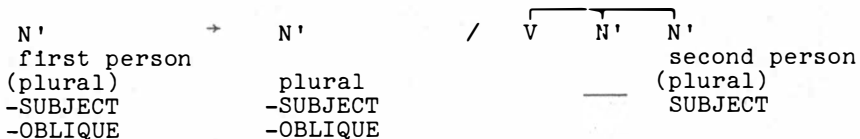

## (T14) -SUBJECT -OBLIQUE N Incorporation Rule

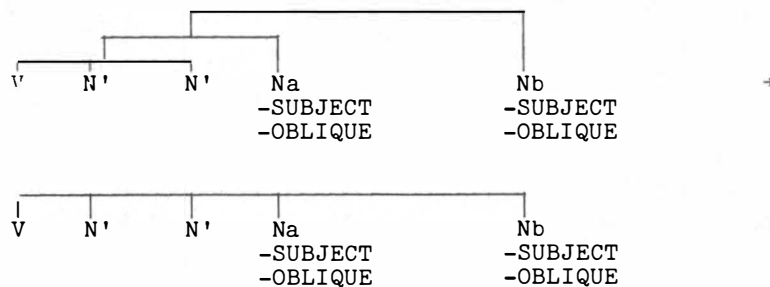

## (T15) -SUBJECT -OBLIQUE (Incorporated) N Transposition Rule

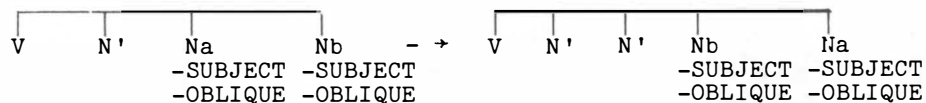

## (T16) V Deletion Rule

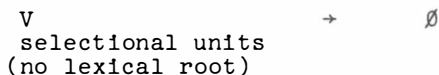

## (T17) V Derivational Units Deletion Rule

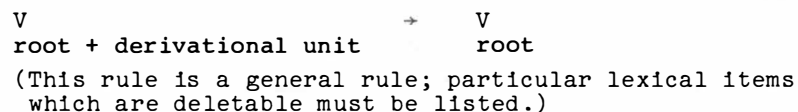

## (T18) Aspect Replacement Rules

V state root generic	→	V state root
V -state root generic	→	V -state root actual durative
V -state root actual durative actual completed actual completed immediate	→	V -state root durative completed immediate

$\alpha$

## (T19) Rel Subject Specification Deletion Rules

V state root rel subject	→	V state root
V process root rel subject	→	V process root
V (process) action root agent subject	→	V (process) action root

-(T1)  
/ -(T2)

## (T20) Rel Subject Specification Neutralisation Rules

V (process) action root*	→	V (process) action root*
{ patient complement instrument measure beneficiary goal source material associate agentive beneficiary }	subject	common subject

$a$

root\* = subset of V roots that take -an

V (process) action root**			V (process) action root**
{ patient complement beneficiary }	subject	→	common subject
			b

root\*\* = subset of V roots that take i-

(T21) V Selectional Units Deletion Rule

V selectional units root inflectional units		→	V root inflectional units
--	--	---	---------------------------------

(T22) N Root Deletion Rule

N selectional units root inflectional units -new -TOPIC		- →	N selectional units inflectional units -new -TOPIC
--	--	-----	--

(T23) N Deletion Rule

N selectional units (no lexical root) inflectional units -TOPIC -OBLIQUE		→	∅
---	--	---	---

(T24) N Derivational Units Deletion Rule

N root + derivational unit		→	N root
(This rule is a general rule; particular lexical items which are deletable must be listed.)			

(T25) N Inflectional Units Deletion Rules

N place unique root inflectional units		- →	N place unique root
N root associative plural total		→	N root associative plural
			/ V state presential

partitive N plural total	- →	partitive N plural
N unique root associative plural	→	N unique root plural
N root -definite plural -SUBJECT -OBLIQUE	→	N root -definite -SUBJECT -OBLIQUE
N' total	- →	N'
N' total	→	N' / V $\overbrace{\text{N' N'}}$ total

(T26) Generic Replacement Rule

N	→	N
generic { [aggregate] } { [plural ] } <sub>α</sub>		{ [definite ] } { [plural definite demonstrative proximate to hearer] } <sub>α</sub>

(T27) N Selectional Units Deletion Rule

N { <(classificatory units)> } x { [(human) (unique)] } root <{(counter) (measure)}> y	→	N { <(classificatory units)> } { [(human) (unique)] } root <{(counter) (measure)}> y
--	---	---

x = other selectional units besides those listed  
y = other inflectional units besides those listed

(T28) Primary Linearisation

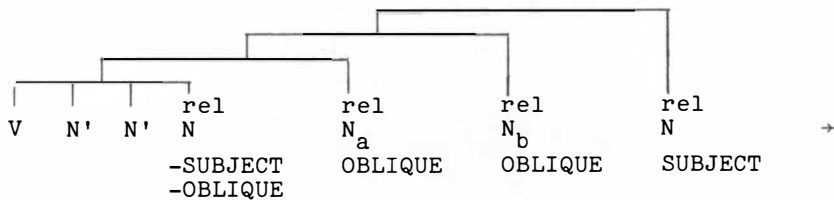



## (T32) Secondary Subjectivisation Rule

N	→	N
TOPIC		
-SUBJECT		SUBJECT
-OBLIQUE		

## (T33) V Linearisation Rule

(Not all the units listed under V are compatible; previous semantic rules would prevent incompatible co-occurrence. The rule is merely intended to suggest how the units are linearised when they DO occur.)

V			
root + derivational unit			→
plural			
repetitive			
intermittent			
perseverative			
intensive			
minutive			
ASPECT			
rel subject			
negative			

negative	intermittent	ASPECT	V
	perseverative		root + derivational unit
	intensive		plural
	minutive		repetitive

## (T34) N' Inter-posing Rule II

negative	V	N'	N'	→	negative N' N' V

## (T35) Verb Root Linearisation Rule

V	
root + (derivational unit)	→
(plural)	V
(repetitive)	PREFIX INFIX ROOT SUFFIX

## (T36) C Linearisation Rule

N	→	N	C
classificatory unit(s)		root	classificatory unit(s)
root		{ counter }	
{ counter }		{ measure }	
{ measure }		y	

y = inflectional units

(T37) N (and C) Linearisation Rule

(The units listed under N are not all compatible; the rules for semantic structure would prevent incompatible co-occurrence. The rule is meant to suggest how these units are linearised when they DO occur.)

N/C  
 classificatory unit(s)  
 human  
 unique  
 root  
 {<—>}  
 plural  
 definite  
 demonstrative  
 total  
 individuated  
 <{counter}>  
 {measure}>  
 {SUBJECT}  
 {OBLIQUE}

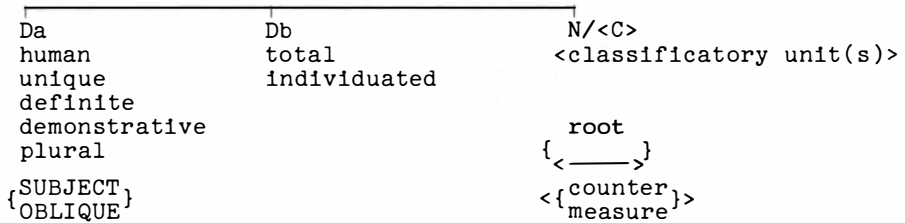

(T38) Quantitative Inter-posing Rule



(T39) N Root Deletion Rule in Partitive Phrases

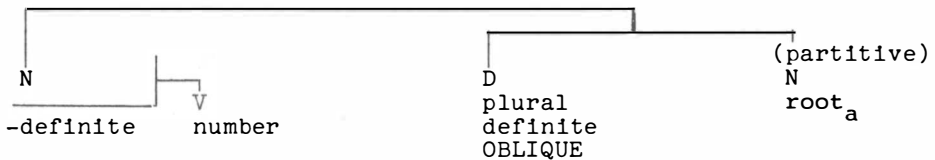

## (T40) Demonstrative Copying Rule

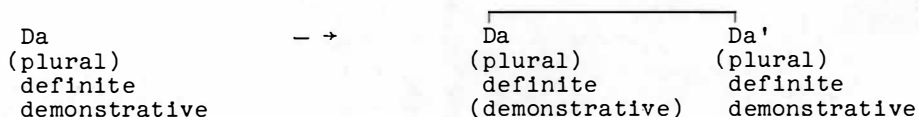

## (T41) Demonstrative Copier Post-posing Rule

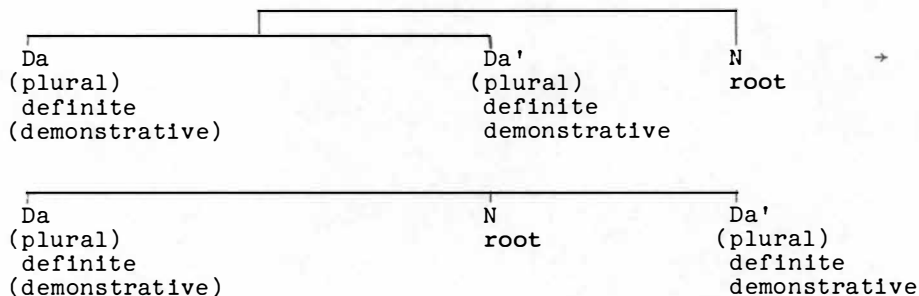

## (T42) Noun Root Linearisation Rule

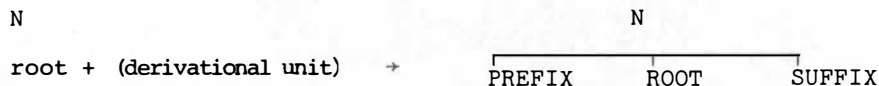

## 2.8.2. Post-semantic Derivation of a Pampangan Sentence

By way of example, the semantic structure derived at the conclusion of Chapter I will be derived post-semantically into a surface structure through the application of the rules re-stated in section 2.8.1. All T numbers refer to this section and not to the preceding sections.

The sentence which was semantically generated in Chapter I was:

- (2.8.2.1) mákibiyé laŋ digálu # kariŋ ának # di Pédrú # kariŋ bábáyi  
 'Pedro and [his] companions are joining the women in  
 giving gift(s) to the children.'

(makibiyé 'to join in giving', digálu 'gift(s)', ának 'children', bábáyi 'women'). Applying the rules of Chapter I, the sentence has the following semantic structure:

SEMANTIC STRUCTURE

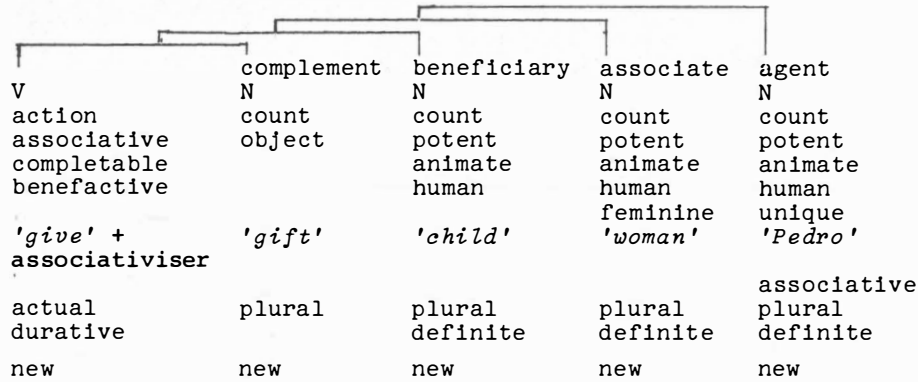

SUBJECT

agent subject

OBLIQUE

OBLIQUE

POST-SEMANTIC PROCESSES

- (1) T4: Subjectivisation Rule
- (2) T5: Subject Incorporation Rule
- (3) T6: Syncretisation Rule

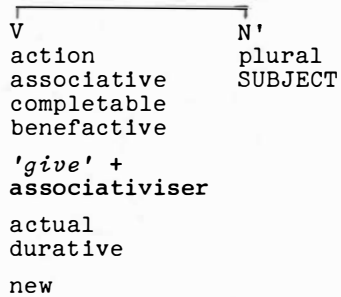

- (4) T9: Subject Incorporation Rule Ia

V	N'	complement
action	plural	N
associative	SUBJECT	count
completable		object
benefactive		
<i>'give'</i> +		
associativiser		<i>'gift'</i>
actual		plural
durative		
new		new
agent subject		
actual → ∅		
agent subject → ∅		

V  
*'give'* +  
 associativiser  
 durative  
 new

complement  
 N  
 count  
 object

*'gift'*  
 plural → ∅

agent  
 N  
 count  
 potent  
 animate  
 human  
 unique  
*'Pedro'*  
 associative → ∅  
 plural  
 definite

(5) T14: -SUBJECT -OBLIQUE N  
 Incorporation Rule

(6) T18: Aspect Replacement

(7) T19: Rel Subject Specifi-  
 cation Deletion Rule

(8) T21: V Selectional Units  
 Deletion Rule

(9) T25: N Inflectional Units  
 Deletion Rule

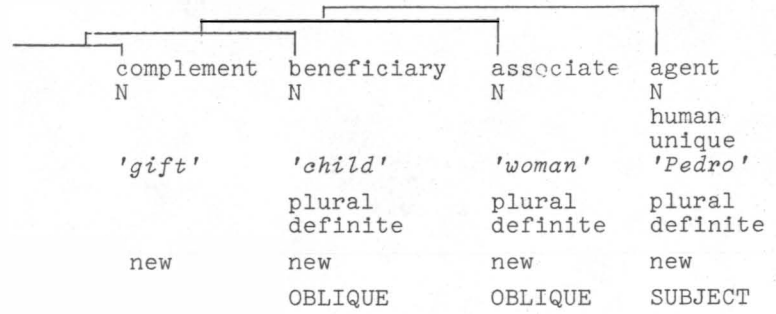

(10) T27: N Selectional Units Deletion Rule

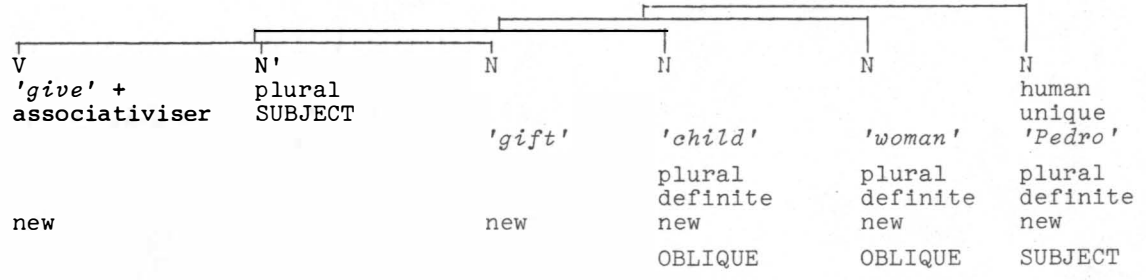

(11) T28: Primary Linearisation Rule

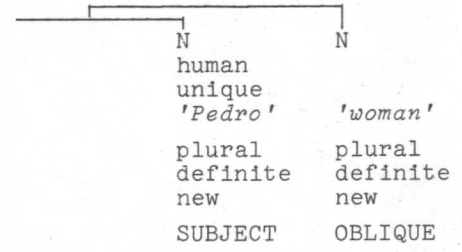

(12) T29: Post-Posing Rule

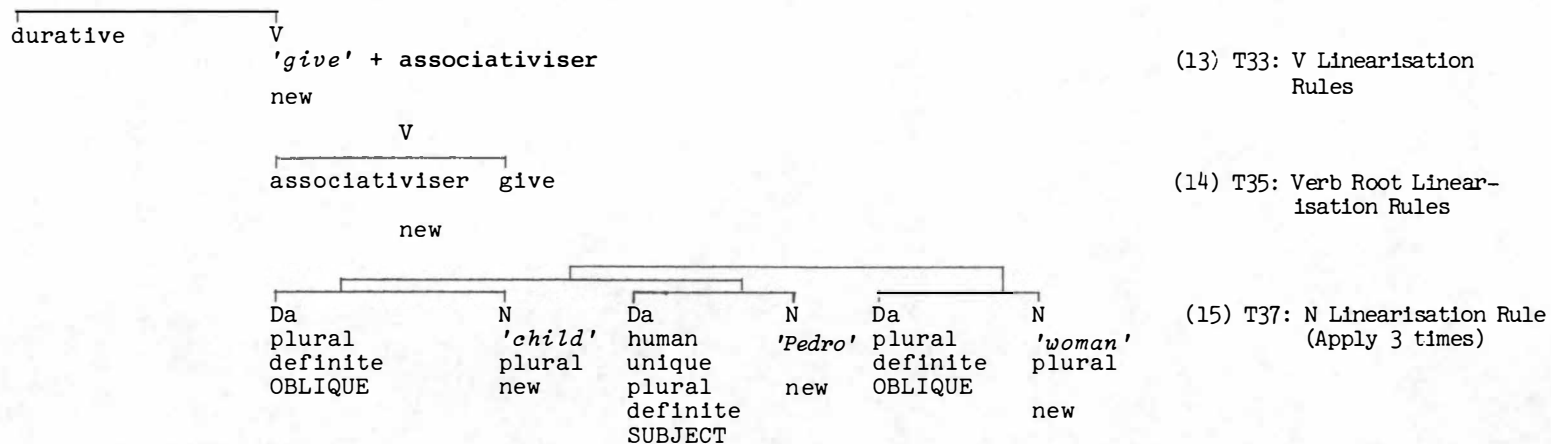

The surface structure is as follows:



## CHAPTER III

### MULTIPLE V'S IN SEMANTIC STRUCTURES

#### 3. INTRODUCTION

This chapter will treat of various topics. It is unified, however, in that every structure considered is a structure of more than one V. The discussion will be informal. As the exposition proceeds, there will be need to add to or revise the semantic and post-semantic rules formulated in Chapters I and II. However, no attempt will be made to integrate these additions and revisions into the sets of rules already formulated in the preceding chapters. As more is learned about the structures of Pampangan, there will be need for further revision and modification. Each one of the topics treated in this chapter is deserving of separate treatment; until these topics are discussed in detail, it will not be possible to have an adequate grammar of Pampangan. In a study of this sort, with quite limited objectives, it would serve no useful purpose to formalise the additions and revisions to the rules to be suggested by structures of more than one V; the rules formulated in Chapters I and II were meant to be suggestive rather than definitive. With knowledge so scarce concerning structures of more complex nature, the formulation of definitive rules would be an unrealistic objective. Rather, the structures suggested by the different topics in this chapter will be described and then informal suggestions will be given as to what post-semantic processes would be required to derive such semantic structures into surface structures.

The first major subdivision of the chapter considers structures in which  $\overbrace{V \quad V}$  are of equal rank; the second major subdivision considers structures in which  $\overbrace{V \quad V}$  are of unequal rank. In the second sub-

division will be treated structures in Pampangan manifesting complementation and embedding, to use the terminology of transformational generative grammar. The final section summarises the chapter by informally discussing the semantic and post-semantic derivation of a complex sentence.

### 3.1. $\overline{V \quad V}$ CONFIGURATIONS OF EQUAL RANK

#### 3.1.1. Explicit Linking

##### 3.1.1.1. Conjunctive

The most unproblematic  $\overline{V \quad V}$  configuration of equal rank is that exemplified by V structures linked by 'and':

- (3.1.1.1.1) malagú ya # i Maryá ## at (saká?) ## maganaká ya # i Ána  
'Maria is pretty and Ana is kind.'

(malagú? 'pretty', maganaká? 'kind', at (saká?) 'and (also)'). A variant of the conjunctive linker is ampó; the latter, in my dialect, is preferable for  $\overline{N \quad N}$  linking. Note that in the example, none of the N's or the V's are repeated. All are marked new (presuming initial discourse) and there is therefore no context for deletion. It is possible, however, to have either V or N, or both V and N, to be repeated in such configurations. Consider first the sentence:

- (3.1.1.1.2) gǫǫilǫ yan kárni # i Pédrú ## at saká?  
## mágbukál yan manúk # i Suán  
'Pedro is slicing meat and Juan is boiling [a] chicken.'

(gǫǫilǫ? 'to slice', kárni 'meat' from Spanish carne, magbukál 'to boil', manúk 'chicken'). Since no repetition of any root occurs, no deletion is possible. It is possible, however, for both V's to have the same root:

- (3.1.1.1.3) gǫǫilǫ yan kárni # i Pédrú ## at saká?  
## gǫǫilǫ yan manúk # i Suán  
'Pedro is slicing meat and Juan is slicing [a] chicken.'

Although both V's have the same lexical unit gǫǫilǫ? 'to slice', no deletion is possible. Neither is there deletion possible if both  $\overline{V \quad N}$  configurations have the same patient N but different verb roots:

- (3.1.1.1.4) gǫǫilǫ yan kárni # i Pédrú ## at saká? ##  
mágbukál yan kárni # i Suán  
'Pedro is slicing meat and Juan is boiling meat.'

However, if both  $\overline{V \quad N}$  configurations share the same verb root and the same (patient) noun root, one may have:

(3.1.1.5) gígilíf yaŋ kárni # i Pédrú #(#) at saká? #(#) i Suán  
*'Pedro and Juan are slicing meat.'*

It should be noted that reference-wise, the two actions are distinct. Pedro and Juan are not participating in the same action, although they are engaging in the same type of activity. Thus, it seems that the context for deletion is not identity of reference, what Frege (1952) calls *Bedeutung*, but identity of meaning, what Frege calls *Sinn*, in the frame of reference used in this study, identity of semantic lexical units. The repeated lexical unit is -new. If deletion is to take place, however, the whole branch, V with all its incorporations, must be deleted, and not just V or incorporated N in V.

Both subjects may be specified as TOPIC, in which case they must be preposed:

(3.1.1.1.6) i Pédrú #(#) at saká? #(#) i Suán # gígilíf iaŋ kárni  
*'As for Pedro and Juan, they are slicing meat.'*

Note, however, that in topicalising the two conjoined subjects, there is an additional post-semantic process pluralising the copier (ya to ia), thus in effect integrating the two conjoined sentences into an even more compact unit. Other examples of this integrating drift will be shown with regard to certain adverbs.

A variant of (3.1.1.1.5) is:

(3.1.1.1.5)\* gí+gíilíf? ya+ŋ kárni # i Pédrú íla na naŋ Suán >  
 gígilíf yaŋ kárni i Pédrú iaŋ Suán  
<sup>x</sup>*'Pedro, they [as well as] Juan, is slicing meat.'* =  
*'Pedro and Juan are slicing meat.'*

What seems to have happened in this sentence is that the conjoined subjects undergo a post-semantic copying process whereby N'  
 plural  
 SUBJECT

symbolised by íla 'they' is generated and inter-posed between the two N's. There is an added post-semantic process deleting SUBJECT in the second N: i to naŋ. Again, this copying process seems to manifest the same tendency towards integration.

It was remarked earlier that when two sentences are conjoined and when they have the same lexical unit for a patient N but different verb roots, such a patient N cannot be deleted. This is true as long as patient N is -definite. If the second patient N is definite (because it refers to the same object), then it can be deleted:

(3.1.1.1.7) gígilíf yaŋ kárni # i Pédrú ## at saká? ## búbukál  
 neŋ Suán (# iŋ kárni)  
*'Pedro is slicing meat, and it [the meat] is being  
 boiled by Juan.'*

In this sentence, the second occurrence of 'meat' is definite, and following earlier rules laid down for extra-position and subjectivisation, it must be extra-posed and subjectivised because definite. Because it is -new, however, it is deletable.

### 3.1.1.2. *Adversative*

Consider the sentence:

- (3.1.1.2.1) malagú ya # i Maryá ## dápot ## é ya maganaká? (# i Maryá)  
'*Maria is pretty, but she is not kind.*'

Besides dápot, there are other symbolisations for 'but': subálit, ónen, and Spanish loanword però (note the accentual shift). Each  $\overline{V \quad N}$  combination undergoes the post-semantic processes already described, with the adversative relation symbolised by the formatives already mentioned. Admittedly, the label 'adversative' does not capture all the uses of dápot; in a more adequate grammar, there may be several types of 'adversative'.

### 3.1.1.3. *Supererogative*

In the sentence:

- (3.1.1.3.1) é ya mu malagú? # i Maryá ## nuṅ é maganaká ya (mu)  
namán (# i Maryá)  
'*Maria is not only pretty but she is likewise kind.*'

Combined in the collocation é mu? (lit. 'not only')...nuṅ é (lit. 'but not')...mu? namán ('also') are notions of conjunction and addition. Perhaps it is best to consider the unit as semantically 'supererogative', an idiom literalised by the units already mentioned in the collocation; the second instance of mu? is optionally deletable. An alternative method of treating the unit 'supererogative' is to directly symbolise it by the collocation and then to posit affix-hopping rules of symbolisation that will distribute these units across the sequence of formatives. The inter-posing of ya between é and mu? has already been discussed in connection with negatives.

### 3.1.1.4. *Purposive*

Consider the sentence:

- (3.1.1.4.1) tínalakád ya # i Pédrú ## bá yaṅ lumákad (# i Pédrú)  
'*Pedro stood up in order that he will walk.*'

Again, no special problems are posed by the structure other than that of inter-posing N' (ya) between ba and the V root. ba symbolises 'purposive'. What is interesting, however, is that through this

inter-posing, the semantic unit 'purposive' is integrated into the V phrase, so that in surface structure, one obtains  $\overbrace{\text{Purposive N' V}}^{\text{SUBJECT}}$ ,

with the loss of boundary marker and the occurrence of linker -ŋ. Exactly how to formulate this change is difficult. The following is merely suggestive:



Another example involving 'purposive' points to still another problem:

- (3.1.1.4.2) míminúm yaŋ panúlu # i Pédrú ## báŋ  
 kaníta ## kumáyap ya (# i Pédrú)  
*'Pedro is taking (lit. drinking) medicine  
 so that (from such an action) he will get well.'*

The analysis of kaníta is problematic. Obviously, it is a symbolisation

for  $\left[ \begin{array}{l} \text{N} \\ \text{(no root)} \\ \text{definite} \\ \text{demonstrative} \\ \text{OBLIQUE} \end{array} \right]$ . Unlike other instances of non-lexically speci-

fied N's, however, kaníta does not refer to an object but seemingly to the whole preceding  $\overbrace{\text{V N}}$  configuration, the fact of Pedro taking his medicine. Strictly speaking then, kaníta is not a pro noun but a pro sentence. If one accepts this analysis, then one must posit a copying process by which whole  $\overbrace{\text{V N}}$  configurations are somehow reified, hence N, and then copied as N' and incorporated into the linker 'purposive'. With such a pro-sentence, the second  $\overbrace{\text{V N}}$  configuration is completely free to undergo the usual post-semantic processes, without further changes from 'purposive'. The process may be described thus:

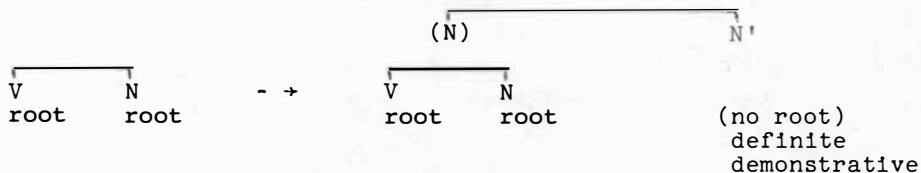

N' would have to be specified as OBLIQUE and then incorporated into the linker:

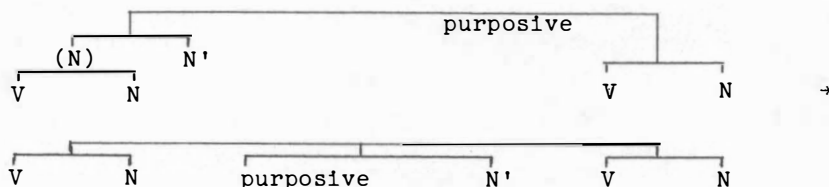

## 3.1.1.5. Resultative

Consider the sentence:

- (3.1.1.5.1) méggóbra ya # i Pédrú ## inyá? ##  
 mfkualtá ya (# i Pédrú)  
*'Pedro worked; hence, he got rich.'*

The first  $\overline{V}$   $\overline{N}$  configuration may be characterised as 'cause' and the second  $\overline{V}$   $\overline{N}$  configuration as 'effect' and this relationship is symbolised by inyá? 'hence, that is why'. Again, no special problems seem to obtain with such cause-effect sentences from the point of view of grammatical structure. The converse of cause-effect sentences are effect-cause sentences, such as:

- (3.1.1.5.2) kákáyap ya # i Pédrú ## úliŋ ##  
 mfinúm yaŋ panúlu (# i Pédrú)  
*'Pedro is getting well because he is taking medicine.'*

The symbolisation of the linker 'causative' is úliŋ 'because'.

## 3.1.1.6. Concessive

In the sentence:

- (3.1.1.6.1) malagú ya mú rin # i Maryá ## { agiyáŋ } ##  
 aglyáman }  
 é ya maganaká? (# i Maryá)  
*'Maria is in any case pretty although  
 she may not be kind.'*

The collocation 'in any case', symbolised by \*mú rin, will be discussed in a subsequent section as a separate unit in itself. Although not absolutely essential, it is preferable to include \*mú rin when using 'concessive', symbolised by agiyá? ~ agiyáman 'although, even if'.

## 3.1.1.7. Disjunctive

## 3.1.1.7.1. Disjunctive Sentences

Consider the sentence:

- (3.1.1.7.1.1) malagú ya # i Maryá † ## o ## masípag  
 ya # i Ána†  
*'Either Maria is pretty, or Ana is hard-working.'*

(o 'or' is probably from Spanish ó; note that the intonation drops at the end of each part of the disjunction). As in conjunctive sentences, the occurrence of the same lexical root presents contexts for deletion. Thus:

- (3.1.1.7.1.2) malagú ya # i Maryá ## o ##  
 malagú ya # í Ana  
*'Either Maria is pretty, or Ana is pretty.'*

The second V is -new because repeated; it has no incorporated N's which are new and which may therefore block deletion. Hence, the second V may be deleted:

- (3.1.1.7.1.2') malagú ya # i Maryá ## o ## i Ána  
*'Either Maria or Ana is pretty.'*

On the other hand, it may be the N root which is lexically the same:

- (3.1.1.7.1.3) malagú ya # i Maryá ## o ##  
 masípag ya # i Maryá  
*'Either Maria is pretty, or Maria is hard-working.'*

With the optional deletion of the -new N, one has:

- (3.1.1.7.1.3') malagú ya # i Maryá ## o ##  
 masípag ya  
*'Either Maria is pretty, or she is hard-working.'*

There is an optional post-posing rule of the SUBJECT N which is possible:

- (3.1.1.7.1.3'') malagú ya #( # ) o #( # ) masípag ya # i Maryá  
*'Maria is either pretty or hard-working.'*

On the other hand, the subject may be marked TOPIC:

- (3.1.1.7.1.3a) i Maryá # malagú ya #( # ) o #( # ) masípag ya  
*'As for Maria, she is either pretty or hard-working.'*

(where → is a notation for non-terminal or sustained pause). The various transpositions exemplified give rise to the deletion of at least one boundary marker when boundary marker is #( # ), since the pause is decidedly shorter. This deletion of one of the boundary markers can probably be formulated as a phonological rule rather than a semantic rule, since it has no semantic import and unlike the deletion of single boundary markers does not signal incorporation.

It is possible, in a disjunction, to have the second  $\overline{V}$  N identical with the first  $\overline{V}$  N except for negative:

- (3.1.1.7.1.4) malagú ya # i Maryá #( # ) o #( # )  
 é ya malagú? # i Maryá  
*'Either Maria is pretty, or Maria is not pretty.'*

The utterance of such a statement is perhaps limited to logic classes, but the sentence is grammatical. With a sentence such as the above, the following deletions are possible:

(3.1.1.7.1.4') malagú ya # i Maryá #(#) o #(#) é ya malagú?  
'Either Maria is pretty, or she is not pretty.'

(3.1.1.7.1.4'') malagú ya #(#) o #(#) é ya malagú? # i Maryá  
'Maria is either pretty, or (she is) not pretty.'

The latter sentence is identical with the former one except for the post-posing of the subject. Another variant is:

(3.1.1.7.1.4''') malagú ya # i Maryá #(#) o #(#) alí ya  
'Either Maria is pretty, or she is not.'

Again, this last sentence may have the subject post-posed:

(3.1.1.7.1.4''''') malagú ya #(#) o #(#) alí ya # i Maryá  
'Maria is either pretty or not.'

In the last two examples, the change in the symbolisation of negative from é to alí should be noted. Finally, the subject may be marked TOPIC:

(3.1.1.7.1.4''''''') i Maryá # malagú ya #(#) o #(#) alí ya  
'As for Maria, she is either pretty, or she is not.'

### 3.1.1.7.2. Disjunctive Clauses in Conjunctive Sentences

Consider the sentence:

(3.1.1.7.2.1) b́sa ya mán † #(#) é ya man b́sa? #  
i Pédrú †##(##) makó ku‡  
'Whether Pedro likes it or does not like  
it, I am leaving.'

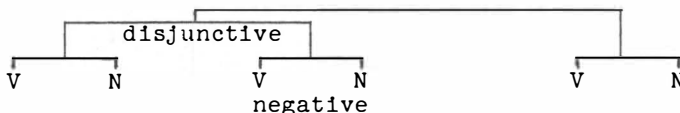

The example is interesting insofar as it shows a disjunction with the symbolisation man...man, probably more representative of the language than the Spanish loanword ó.

Moreover, the terminal markers for intonation (‡ for unmarked breath-group, † for marked breath-group, → for sustained pause: the notation is a mere convenience and is not based on phonemic theory) are interesting. At the end of the first part of the disjunction, there is a marked breath-group (the label is based on Lieberman 1967). It will be seen in Chapter IV that the same phenomenon (marked breath-group) occurs at the end of the first clause of a disjunctive interrogative. In disjunctive statements, however, the unmarked breath-group occurs at the end of each part of the disjunction, except seemingly when the disjunctive statement is part of a larger statement, in which case the marked breath-group occurs.

Chafe (see 1970b, Chapter 19) proposes, quite convincingly, that in English, the marked breath-group arises not because of the unit 'interrogative' but because of the unit 'disjunctive'. In Pampangan, initially, this does not seem to be so, since it was found that in ordinary disjunctive statements, † occurs at the end of each part of the disjunction. However, if one takes † to be a marker for 'interrogative', it will be difficult to explain why † occurs in sentence (3.1.1.7.2.1) and in a sentence such as

- (3.1.1.7.2.2) dátaŋ ya<sup>→</sup> # i Pédro † #(# ) o #(# ) i Suán†  
'Either Pedro or Juan will arrive.'

where † occurs and where 'interrogative' is clearly absent; † is the context for the u > o shift in Pédro

Because of the occurrence of sentences (3.1.1.7.2.1) and (3.1.1.7.2.2), tentatively, I shall take the position that † is a marker not for 'interrogative' but for 'disjunctive'. I am now left with the problem of accounting for the occurrence of † in disjunctive questions.

I shall account for the latter by postulating a phonological rule

$$\begin{array}{ccccccc}
 \text{(Ph.} & \text{)} & \uparrow & \rightarrow & \downarrow & / & \boxed{\begin{array}{c} \text{disjunctive} \\ \text{-interrogative} \end{array}} \\
 & & & & & & \begin{array}{c} \text{V} \qquad \qquad \qquad \text{V} \\ \text{---} \end{array} \\
 & & & & & & \text{##}
 \end{array}$$

the motivation of which seems to be the avoidance of homophony. It will be shown in Chapter IV that yes-no questions in Pampangan are differentiated from corresponding statements only by intonation, since there is no interrogative marker or change in word order:

- (3.1.1.7.2.3) dátaŋ ya<sup>→</sup> # i Pédro† #(# ) o #(# ) é ya  
dátaŋ<sup>→</sup> # i Pédro†  
'Either Pedro will come, or Pedro will not come.'

- (3.1.1.7.2.4) dátaŋ ya<sup>→</sup> # i Pédro† #(# ) o #(# ) é ya  
dátaŋ # i Pédro†  
'Will Pedro come, or will Pedro not come?'

To prevent homophony, the phonological rule applies to (3.1.1.7.2.3). In larger statements, however, where the context would disambiguate any potential ambiguity, there is no need for the phonological rule and the usual symbolisation for 'disjunctive' (†) occurs:

- (3.1.1.7.2.5) dátaŋ ya mánt † #(# ) é ya man dátaŋ<sup>→</sup> #  
i Pédro<sup>→</sup> ##(##) makó ku†  
'Whether Pedro will come or Pedro will not come,  
I am leaving.'

3.1.1.8. *Conditional*

A  $\overline{V \quad V}$  configuration of equal rank may be specified as conditional, expressing an if-then relation:

- (3.1.1.8.1) nuḡ murán ## luḡúb ya # kiḡ balé # iḡ anák  
*'If it rains, the child will go into the house.'*

in which the condition is factual and non-generic. It seems that unmarked conditions of this type have the added stipulation that the apodosis (or then clause) must also be specified as -actual (aspect). Any other aspect specification would bring in the notion of inference, which will be discussed in Chapter IV, or a general condition:

- (3.1.1.8.2) nuḡ minurán ## línub ya # kiḡ balé # iḡ anák  
*'If it rained, then [I infer that] the child went into the house.'*

- (3.1.1.8.3) nuḡ múmurán ## lúlub ya # kiḡ balé # iḡ anák  
*'Whenever it rains, the child goes into the house.'*

The latter sentence is generic. In generic conditions, other symbolisations of 'if' are ustúḡ 'whenever' (from Spanish *justo* 'punctually'), or patiyé 'whenever' or andát ~ indát 'whenever'. In generic conditions, both V's are usually generic. However, it is possible to have the second V -actual, as in:

- (3.1.1.8.4) núḡ múmúran # kéní # aldóldó ## makó ku  
*'If it rains here every day, then I shall leave.'*

It is possible for a conditional to be specified as contra-factual (or subjunctive):

- (3.1.1.8.5) nuḡ dínatán ya sána # i Pédro ##  
 mintá kamí sána # kiḡ pistá  
*'If Pedro had come, then we would have gone to the fiesta [but he did not come].'*

Contra-factual sentences pre-suppose a previous occurrence which contradicts the protasis (or 'if' clause). The semantic structure of the sentence may be represented thus:

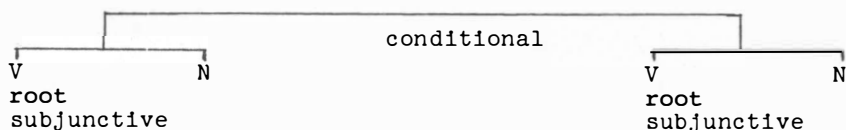

The unit 'subjunctive' may thus be considered an inflectional unit specifying the V matrix further as 'contrary to fact' in the same way that in Chapter I, 'negative' was considered as specifying a V matrix further. Since 'subjunctive' may specify any V root and does not serve

to narrow down lexical choice to a particular unit, it is best seen as an inflectional unit. In Pampangan, the unit specifies both V's in a conditional sentence and is eventually linearised and symbolised as *sána*.

In contra-factual or subjunctive conditions, the state or event may be specified for its usual aspectual possibilities; the only restriction seems to be that if  $V_1$  is -actual, then  $V_2$  must likewise be -actual. If  $V_1$  is actual,  $V_2$  may be specified for any aspect, dictated only by reality:

(3.1.1.8.6) nuṅ dátaṅ ya *sána* # i Pédro ## muntá  
kamí *sána* # kiṅ pistá  
*'If Pedro were coming, we would then go  
to the fiesta (but he is not coming).'*

(3.1.1.8.7) nuṅ dínatáṅ ya *sána* # i Pédro ##  
muntá kamí *sána* # kiṅ pistá  
*'If Pedro had come, then we would go to  
the fiesta (but he did not come).'*

(3.1.1.8.8) nuṅ dínatáṅ ya *sána* # i Pédro ##  
púpuntá kamí *sána* # ḡéni # kiṅ pistá  
*'If Pedro had come, then we would be going  
to the fiesta right now (but he did not come).'*

A conditional sentence can be both generic and subjunctive:

(3.1.1.8.9) nuṅ é ya *sána* mamamaté # iṅ táu ##  
magíṅ paraisú ya *sána* # iṅ yátuṅ ití  
*'If man were not mortal (lit. is not dying)  
then this world would become a paradise.'*

Unlike English, Pampangan shows no post-semantic aspectual shifts necessary for different conditional combinations. Aspectual specification seems to arise from the constraints of extramental reality itself, with no necessary post-semantic shifts in aspectual specification to derive surface structures. Rather, markers such as 'subjunctive' are symbolised by particles such as *sána* and *sá?* linearised within the V phrase.

### 3.1.1.9. Summary

The discussion in the preceding sections may be summarised by the rule (conceived of as a semantic rule necessary for  $\overline{V}$  V structures):





$N_2$  is semantically marked as additive, from the preceding linguistic context; post-semantically, however, 'additive' is incorporated into V. This specification in V renders  $V_1$ , which is -new, immune from deletion. Eventually, 'additive' is linearised within the V phrase and symbolised as (mu) namán. On the other hand, it may not be N but V which is specified initially as additive:

- (3.1.2.1.2) lálákad ya # i Pédro ##  
 bábása yá namañ (# i Pédro)  
 'Pedro is walking.'  
 '[In addition to walking] he is likewise reading.'  
 '(He is reading while walking).'

The structure may be shown thus:



Since the second  $N_1$  is -new and since it has no other specifications which would block deletion, the second  $N_1$  is deleted. 'Additive' is incorporated into  $V_2$  and is eventually linearised in  $V_2$  and symbolised as namán. (Note the similarity as well as difference in symbolisation with an additive arising from N, (mu) namán.) Because of optional mu, ambiguity obtains in a sentence such as:

- (3.1.2.1.3) mágáral yá namán # in anák  
 'The child [like someone else] is studying.'  
 'The child [in addition to doing other things]  
 is studying.'

The first meaning may be expressed unambiguously by:

- (3.1.2.1.3') mágáral yá mu namán # in anák

Or 'child' may be TOPIC and pre-posed:

- (3.1.2.1.3") in anák man mágáral ya  
 'As for the child, he [like someone else]  
 is studying.'

Note that in the above instance, 'additive' is not incorporated into V but stays as a unit under (pre-posed) N. Of course, it is possible to say:

- (3.1.2.1.4) iŋ anák man # mágáral yá namán  
 'As for the child, he [like someone else] is likewise  
 studying [in addition to doing other things].'

### 3.1.2.2. Iterative

Consider the sentence:

- (3.1.2.2.1) línákad ya # nápun # i Pédrú ##  
 línákad né namán # ǵéni (# i Pédrú)  
 'Pedro walked yesterday.'  
 'He again walked today.'

The semantic structure of the sentence is:



The second occurrence of  $V_1$  is specified as iterative; this additional specification seems to block deletion (as did the specification additive). On the other hand,  $N_1$  is deleted since it has the necessary context for deletion. It is possible to have a predicate noun specified as iterative:

- (3.1.2.2.2) nínú # iŋ minyambút  
 i Pédrú na namán # iŋ minyambút  
 'Who is it who won?'  
 'It was Pedro again who won.'

The symbolisation of 'iterative' is na namán (na in this collocation must not be confused with non-subject and non-oblique copier na). 'Iterative' occurs when V and N are a repetition of a preceding V and N and is incorporated only into V.

### 3.1.2.3. Seriative

Consider the sentences:

- (3.1.2.3.1) dakál ya gáwan # i Pédrú ##  
 sfnúlat ya (# i Pédrú) ##  
 magáral ya pá (# i Pédrú)  
 'Pedro has many things to do.'  
 'He wrote [a letter].'  
 'He will still study.'

The structure is:

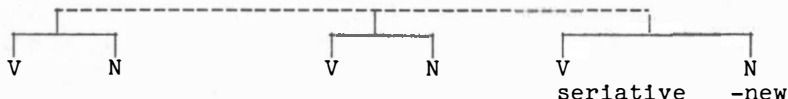

pa signals that V is part of a series, something still remaining. If the sequence of actions is located in the past, it is possible to have V actual:

- (3.1.2.3.2) mégóbra ya # i Pédro ##  
 línákad ya pá (# i Pédro)  
 'Pedro worked.'  
 'He still walked.'

However, when the temporal specification is -past, V is usually -actual, since it expresses something still waiting to be done.

In the sentence sequence

- (3.1.2.3.3) línákad ya # nandín ábak # i Pédro ##  
 lálákad ya pá # nénéi (# i Pédro)  
 'Pedro [began to] walk this morning.'  
 'He is still walking now.'

It is not clear whether pa expresses a different semantic unit '-completed' to emphasise aspectual 'durative'. For the moment, I shall subsume '-completed' under 'seriative'. Clearly pa is seriative when it occurs with a predicate noun:

- (3.1.2.3.4) nínu pa # in dáratán  
 i Pédro pa # in dáratán  
 'Who else is arriving?'  
 'Pedro still [is to be listed among] those  
 who are arriving.'

Seriative may be specified of either V or N. The following example presents an interesting instance of ambiguity: If one wanted to ask in Pampangan 'Who is still eating?', it would seem that the correct utterance would be:

- (3.1.2.3.5)<sup>x</sup> nínu # in mámanán pa  
 'Who is it who is eating still?'

However, there seems to be a general constraint against placing the formatives being discussed in this section (3.1.2) outside of the initial phrase, which is usually V, so that pa must be incorporated into the initial phrase:

- (3.1.2.3.5') nínu pa # in mámanán

which now becomes ambiguous, since it may mean:

- 'Who else is eating?'  
 'Who is still eating?'

3.1.2.4. *Subitive*

Consider the sentences:

- (3.1.2.4.1)\* még+áral na ya # iŋ ának >  
 mégáral ne # iŋ anák  
 'The child has already studied.'

(na 'already' is not to be confused with copier na 'non-subject and non-oblique he'.)

- (3.1.2.4.2)<sub>x</sub> magáral na ká  
 'Study already.' = 'Study [it's time].'

- (3.1.2.4.3) makó ne # i Pédru  
 'Pedro is ready to leave.'

It is difficult to characterise the meaning of na; it is not even clear whether several units are expressed homophonously by na. Tentatively, the meanings are subsumed under 'subitive', admittedly an unsatisfactory label. Perhaps 'immediate' would be more apropos; however 'immediate' has been used in connection with aspect. Although both concepts are clearly related and even co-occur, they must be kept separate; hence, the choice of a different label. Moreover, it is difficult to characterise the preceding linguistic context that gives rise to na because there are so many possible ones: when na occurs with a command, it means that the person giving the mandate is telling the executor that it is time to accomplish the task; on the other hand, na may signal posterior, not prior, immediacy, as when one reports that something has been accomplished. Again, one may report that a state or situation obtains as expected, as in:

- (3.1.2.4.4) masalése ne # i Pédru  
 'Pedro is already well [he was sick before].'

The occurrence of na may be semantically represented thus:

VARIOUS PRE-SUPPOSITIONS  $\overline{\text{V} \quad \text{N}}$   
 subitive

Another interesting occurrence of na is:

- (3.1.2.4.5) SPEAKER A: nínu # iŋ magóbra  
 SPEAKER B: i Pédru na # iŋ magóbra  
 'Who is it who will work?'  
 'Let Pedro be the one who will work.'

where now na does not signal 'subitive' but 'selective'. Conative functions of language will be discussed in detail in Chapter IV. It seems that 'selective' is a distinct unit from 'subitive'.



3.1.2.7. *Caditive*

Consider the sentence:

- (3.1.2.7.1) *lumákad yá mú rin # i Pédru*  
 '(No matter what happens) Pedro will walk.'

where the semantic structure is representable as:

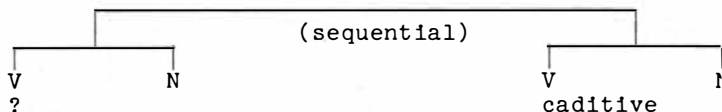

In structures of this type, the previous context may be any event or state which in point of time is prior to what is expressed (hence, what is expressed is sequential to what is unexpressed) and the expressed V incorporates 'caditive' as an inflectional marker (from *cadere* 'to fall, happen'), translatable as 'in any case'. 'Caditive' is symbolised by \*(mu)din. Again, 'caditive' may be incorporated into a predicate noun:

- (3.1.2.7.2) *i Pédru mú rin # in gáwa kin balé*  
 'The one who will build the house will be  
 Pedro in any case.'

3.1.2.8. *Explanative*

Consider the sentence:

- (3.1.2.8.1) *métudtúd ya # i Pédru ##*  
*mitutundú ya kasí (# i Pédru)*  
 'Pedro went to sleep.'  
 '(Because) he was sleepy.'

where the semantic structure is representable as:

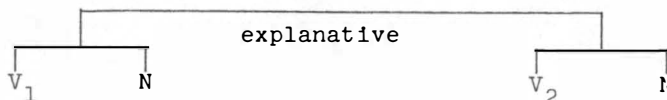

The unit 'explanative' is incorporated into  $V_2$ , although semantically, it is the whole  $\overbrace{V_2 \quad N}$  configuration which explains the reason for  $\overbrace{V_1 \quad N}$ . 'Explanative' is post-semantically linearised and symbolised by *kasí*.

3.1.2.9. *Summary*

In addition to the units which may specify the link between two V's of equal rank, the units 'explanative' and 'sequential' must be posited:

$$(S) \quad \overbrace{V_1 \quad V_2} = \quad - \rightarrow \quad \left\{ \begin{array}{l} \text{explanative} \\ \text{sequential} \end{array} \right\}$$

What makes the two units above different from the other overt linkers discussed in section 3.1.1 is that they are not directly symbolised by particles but provide the context for the incorporation of units into either V, units which in turn are symbolised by particles within the V phrase:

$$(S) \quad V_1 \quad - \rightarrow \quad \text{precedent} \quad / \quad \overbrace{V_1 \quad V_2} = \text{sequential} =$$

$$(S) \quad V_2 \quad \rightarrow \rightarrow \quad \text{explanative} \quad / \quad \overbrace{V_1 \quad V_2} = \text{explanative} =$$

The above two rules may be integrated into more general rules:

$$(S) \quad V_1 \quad - \rightarrow \quad \text{precedent} \quad / \quad \overbrace{V_1 \quad V_2} = \text{sequential} =$$

$$(S) \quad V_2 \quad - \rightarrow \quad \left( \begin{array}{l} \text{additive} \\ \text{solitive} \\ \text{iterative} \\ \text{subitive} \\ \text{seriative} \\ \text{cadtive} \\ \text{explanative} \end{array} \right) \quad / \quad \text{in various}$$

preceding linguistic contexts in  $\overbrace{V_1 \quad V_2}$   
configurations or with various pre-suppositions

The reasons for the co-occurrence restrictions of the various specification units of  $V_2$  seem to be phonological rather than semantic. Semantically, there is nothing to prevent the specifications from occurring together, except perhaps 'additive' and 'solitive', although cases are imaginable when the two may co-occur. Rather, what seems to prevent occurrence together is the avoidance of homophony, since many

of the symbolisations are quite similar, and in the case of discontinuous morphs, some particles are identical:

precedent	pa?	(mu?)
seriative	pa	
solitive	mu?	(namán)
additive	(mu)	namán
iterative	na	namán
subitive	na	
caditive	(mu)	din
explanative	kasí	

The linearisation rule for such particles is quite rigid:

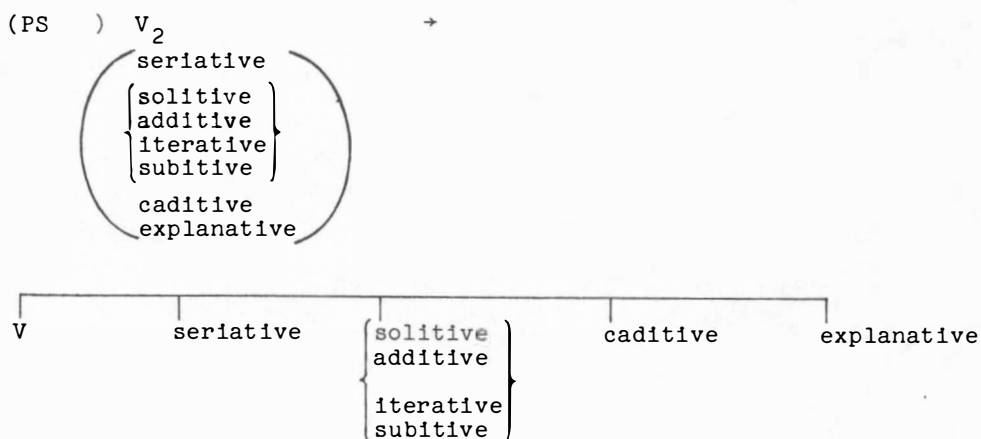

An example of a maximally specified V<sub>2</sub> would be:

(3.1.2.9.1) lálákad ya pá mu namán din kasí # i Pédro  
*'Because, in any case, Pedro is still only walking (he is doing nothing else).'*

where the verb is V is linearised as

walk	seriative	solitive	caditive	explanative
lálákad	ya pá	mu? namán	din	kasí

Fortunately, the particles do not occur in such formidable combinations in actual usage.

The units discussed are interesting since they act as linkers in discourse and would no doubt figure prominently in a semantic analysis that is extended to the discourse level. Moreover, they mirror pre-

ceding sentences which may not immediately precede the sentence in which they are incorporated. It is thus possible to carry over into succeeding sentences indicators from previous sentences quite distant from the present sentence being uttered.

In Chapter IV, other particles which may be incorporated into V in addition to those discussed thus far will be described.

### 3.2. $\overbrace{V \quad V}$ CONFIGURATIONS OF UNEQUAL RANK

The structures to be described in this second major division of the chapter consist of structures of more than one V. Unlike the structures discussed in the first division, however, the second V in these structures is unequal in rank with regard to the first V. In this section will be discussed different types of adverbs, nominalisation, complementation, and relativisation.

#### 3.2.1. $\overbrace{V \quad V} \quad \overbrace{N}$ Configurations

##### 3.2.1.1. Manner Adverbs

Consider the sentence:

(3.2.1.1.1) *masalése yaŋ káwe # iŋ anák*  
'The child swims well.'

The basic configuration seems to be

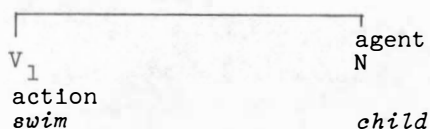

Now, *masalése* 'well, adeptly', a state V in its own right, specifies the verb root 'to swim' further by describing the manner of swimming. It is necessary then in semantic representation to show the relation between V<sub>1</sub> and this new state V<sub>2</sub>; at the same time, it is necessary to show that this relation obtains only between V<sub>1</sub> and V<sub>2</sub> and not between V<sub>2</sub> and the agent N. Chafe (1970b) would represent the above sentence as:

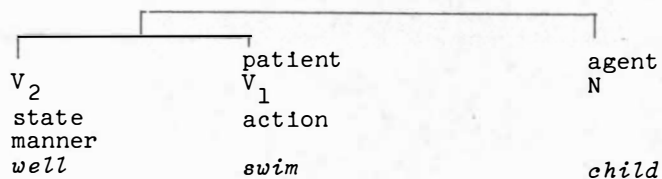

I find the above representation unsatisfactory insofar as it does not seem to show the subordination of  $V_2$  to  $V_1$  adequately nor does it neatly represent the stipulation that the agent N accompanies  $V_1$  and not  $V_2$ . Tentatively, I would like to propose that  $V_2$  is a kind of inflectional unit specifying  $V_1$  further and like any inflectional unit not really serving to narrow down lexical choice to a particular unit but pre-supposing lexical choice and adding new specifications to this already selected lexical unit. Hence:

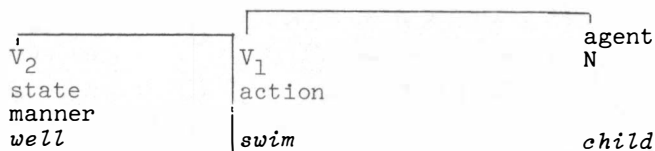

The post-semantic processes that the above configuration would have to undergo are: subjectivisation of the agent N, incorporation of specifications of the agent N into  $V_1$ , inter-posing of the copier  $ya$  between  $V_2$  and  $V_1$ , and various linearisations.

Sentence (3.2.1.1.1) is ambiguous, since it means

*'The child is swimming well [right now].'*

*'The child [habitually] swims well.'*

The second meaning is more naturally expressed by sentence (3.2.1.1.1); it should be noticed that the aspectual specifications of  $V_1$  have been post-semantically deleted. If one wanted to maintain the overt marking for actual durative, one would apply a permutation rule:

(3.2.1.1.1')  $kákawé\ ya\ \eta\ masalése\ \#\ i\ \eta\ anák$

*'The child is swimming well.'*

It is possible for  $V_2$  to be inflectionally negative:

(3.2.1.1.2)  $é\ ya\ masalése\ káwe\ \#\ i\ \eta\ anák$

*'The child does not swim well.'*

Note that when  $ya$  is interposed between negative and  $V_2$ , the linker  $-\eta$  does not occur whereas when  $ya$  is interposed between  $V_2$  and  $V_1$ , the linker  $-\eta$  does occur. It was stated earlier that the linker occurs when two branches (N and/or V) previously separate are incorporated into one branch, which is what happens when  $ya$  is inter-posed between  $V_2$  and V:



The specification 'negative', however, does not arise from a separate branch but from an inflectional unit of  $V_2$ . When N' is interposed

between negative and  $V_2$ , the two branches have already been incorporated into one branch; hence, the non-occurrence of the linker  $-n$  finds a plausible explanation by appeal to rule ordering.

In sentences such as (3.2.1.1.2), the copier  $ya$  is optionally deletable:

(3.2.1.1.2')  $\acute{e}$  masalése káwe # in anák

If the subject is  $-new$ , the whole branch may be deleted, yielding a surface structure without overt reflexes of accompanying N's (from this point of view, similar to structures with ambient V's):

(3.2.1.1.2")  $\acute{e}$  masalése káwe  
'He does not swim well.'

In Chapter I, sentences such as

(3.2.1.1.3) máyap yaŋ máyap # in anák  
'The child is exceedingly good.'

were analysed as having state V inflectionally specified as 'intensive'; in turn, the unit 'intensive' was symbolised by the re-duplication process. An alternative would be to analyse 'intensive' as arising from a separate state V:

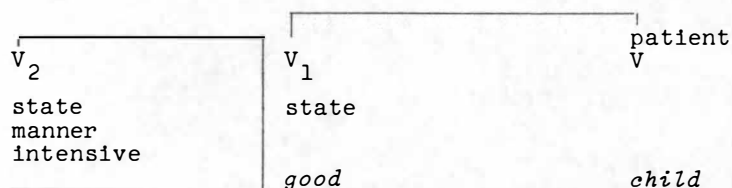

In this case, the  $V_2$  branch is not lexically specified; a post-semantic process would copy the root of  $V_1$  into  $V_2$ , thus generating the re-duplication quite neatly. If one accepts this analysis, then a sentence such as

(3.2.1.1.4)\*  $l\acute{a}+l\acute{á}kad$  na yaŋ  $l\acute{á}+l\acute{á}kad$  # i Pédro  
 $l\acute{á}l\acute{á}kad$  neŋ  $l\acute{á}l\acute{á}kad$  # i Pédro  
'Pedro perseveres in walking.'

would be analysable as

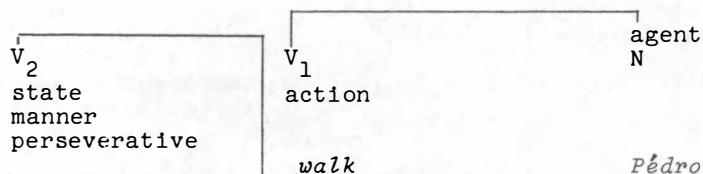

where again the state V is not lexically specified but post-semantically accepts an incorporated verb root from  $V_1$ . The interposed *na* (distinct from copier *na* and 'subitive' *na*) is introduced post-semantically and is semantically vacuous.

### 3.2.1.2. Frequency and Instance Adverbs

Consider the sentence:

- (3.2.1.2.1) *maralás yaŋ kákawé # i Pédro*  
'Pedro swims often.'

where again it seems that the nucleus of the sentence is

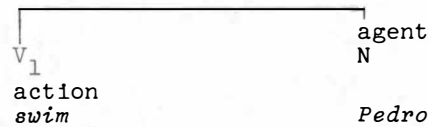

Now the notion of frequency of 'often' specifies 'to swim' quasi-inflectionally; moreover, it is not directly related to the agent N. For this reason, it seems to share properties of manner adverbs (and in surface structure appears as a manner adverb). Hence:

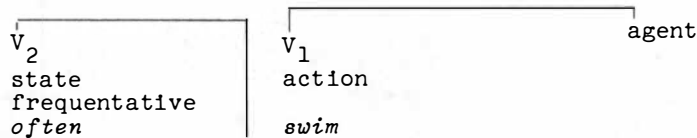

Again, the usual post-semantic processes apply: subjectivisation of the agent N, incorporation of specifications of the agent N into  $V_1$ , interposing of the copier between  $V_2$  and  $V_1$ , and various linearisations.

Instead of frequentative,  $V_2$  may be specified as instantive; in such cases, the verb root is usually a form derived from a number formative:

- (3.2.1.2.2) *makatatlú yaŋ kínawé # i Pédro*  
'Pedro swam three times.'

where *makatatlú?* is analysable as *three* + instantiviser.

### 3.2.2. V V N Configurations

#### 3.2.2.1. Sentential Adverbs

##### 3.2.2.1.1. Commentative, Validative, Certainative, Necessitative, Frequentative

Consider the sentence:

- (3.2.2.1.1.1) *máyap #(#) iŋ kákawé ya # iŋ anák*  
'The [fact that] the child is swimming  
is good [to hear].'

The semantic structure of the sentence is:

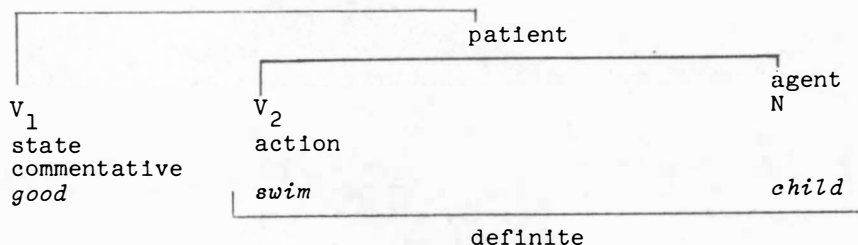

where the embedded  $\overline{V_2}$  N sub-configuration is in a patient relation to the commentative state  $V_1$ . It is necessary to differentiate sentence (3.2.2.1.1.1) from a sentence such as:

- (3.2.2.1.1.2) máyap yan káwe # iŋ anák  
'The child swims well.'

The first sentence has a sentential adverb predicated of a  $\overline{V}$  N configuration while the second sentence has a manner adverb predicated of another V. The nominal nature of the embedded patient is corroborated by the definite specification (itself the context for the subjectivisation of the whole clause). Since the embedded sub-configuration is abstract, it is not copied into  $V_1$ . However, within the embedded  $\overline{V}$  N configuration, the usual post-semantic processes of subjectivisation and incorporation apply.

By a later deletion process, the determiner iŋ is optionally deletable, so that one can have the variant:

- (3.2.2.1.1.1') máyap #(#) kákawé ya # iŋ anák  
'[That] the child is swimming is good [to hear].'

It should be noted that if the boundary marker is not # but ##, as in

- (3.2.2.1.1.3) máyap ## kákawé ya # iŋ anák  
'Good: The child is swimming.'

the sentence, although semantically similar to (3.2.2.1.1.1) in its overall communicative effect, has a different semantic configuration. In sentence (3.2.2.1.1.3) what obtains is a  $\overline{V}$   $\overline{V}$  configuration of equal rank with no overt marker between the two V's.

The negative counterpart of (3.2.2.1.1.1) is:

- (3.2.2.1.1.1a) é mayap #(#) iŋ kákawé ya # iŋ anák  
'The [fact that] the child is swimming is not good [to hear].'

In the above example, the subject determiner iŋ is not deletable; hence, the specification 'definite' is necessary in semantic structure.

Other types of sentential adverbs (validative, certainative, necessitative) need only exemplification:

- (3.2.2.1.1.4) tutú? #(#) iη kákawé ya # iη anák  
'The [fact that] the child is swimming is true.'
- (3.2.2.1.1.5) pífú #(#) iη kákawé ya # iη anák  
'The [fact that] the child is swimming is almost certain.'
- (3.2.2.1.1.6) kailáŋan #(#) iη káwe ya # iη anák  
'The [happening that] the child will swim is necessary.'

In the above sentences, it is possible for the boundary marker to be deleted altogether; phonologically, this deletion provides the context for vowel syncope and in (3.2.2.1.1.6) nasal simplification:

- (3.2.2.1.1.4') tutú+ŋ kákawé ya # iη anák  
(3.2.2.1.1.5') pífú+ŋ kákawé ya # iη anák  
(3.2.2.1.1.6')\* kailáŋan+ŋ káwe ya # iη anák >  
kailáŋan káwe ya # iη anák

It was necessary to list the variants to show their essential sameness; failure to note their essential sameness leads to difficulties in analysis. Moreover, (3.2.2.1.1.5) has a variant:

- (3.2.2.1.1.5") pífú yaŋ kákawé # iη anák

where the interposition of the copier makes the surface structure similar to the surface structure of sentences with manner adverbs.

In section 3.2.1.2, frequency adverbs were discussed. There, it was stated that frequency adverbs in general do not modify a  $\overline{V \quad N}$  configuration but only another V. However, it is likewise possible to have a frequency adverb as a sentential adverb. Contrast the two sentences:

- (3.2.2.1.1.7) maralás yaŋ kákawé # iη anák  
'The child swims often.'
- (3.2.2.1.1.8) maralás #(#) iη kákawé ya # iη anák  
'The [fact that] the child is swimming [happens] often.'

The specification generic usually co-occurs with a frequentative sentential adverb:

- (3.2.2.1.1.9) a|dó|dó #(#) kákawé ya # iη anák  
'That the child is swimming [happens] daily.' =  
'Daily the child swims.'

Other derived frequentative state V's are béŋibéŋi 'nightly' (lit. *night + night*) and búlanbúlan 'monthly' (lit. *moon + moon*). Sentences such as (3.2.2.1.1.9') usually delete the determiner iη; its retention would render the sentence unnatural although not ungrammatical. Moreover, the frequentative state V may be post-posed or interposed:

(3.2.2.1.1.9') kákawé ya # iη anák #(#) aldóldó  
 kákawé ya #(#) aldóldó #(#) iη anák

### 3.2.2.1.2. Adverbial Phrases of Place, Time, Benefaction, and Motivation

#### 3.2.2.1.2.1. Locative

Consider the sentence:

(3.2.2.1.2.1.1) kiη balé # iη pistá  
 'The fiesta [is taking place] in the house.'

A simple structure such as the above may be juxtaposed and compared to a more complicated structure which seems to manifest the same basic configuration:

(3.2.2.1.2.1.2) kiη balé ## mégáral ya # iη anák  
 'In the house the child studied.'

In both examples, what seems to obtain is an object or event (with its accompanying dramatis personae) located in some space; in other words, the semantic structure of the first example seems to be

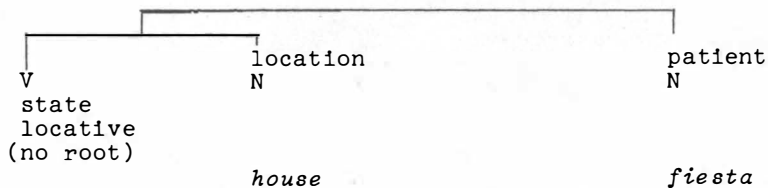

while the semantic structure of the second example is

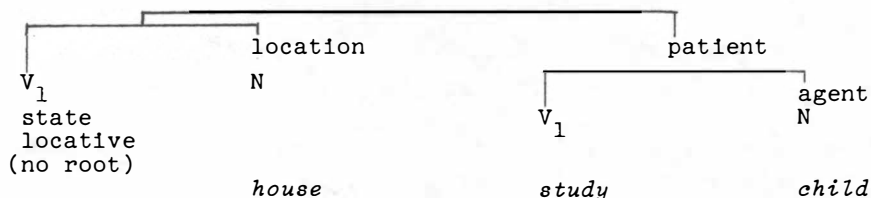

Since the locative state V is not lexically specified, it is deleted. On the other hand, the patient sub-structure undergoes the usual post-semantic processes of any V (subjectivisation and incorporation and various linearisations), finally yielding the surface structure:

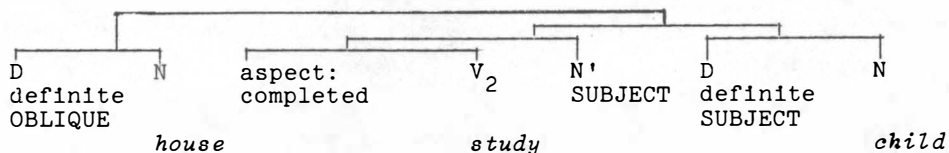

The location N may be post-posed, yielding the preferred variant:

(3.2.2.1.2.1.2') mēgáral ya # iṅ anák #(#) kiṅ balé

Or the location N may be interposed between  $V_2$  and subject:

(3.2.2.1.2.1.2'') mēgáral ya #(#) kiṅ balé #(#) iṅ anák

If the location N is specified as TOPIC, it must be pre-posed:

(3.2.2.1.2.1.2''') kiṅ balé ye mēgáral # iṅ anák  
*'It was in the house that the child studied.'*

Still another possibility is offered for location N. If location N is -new, as in the sequence

(3.2.2.1.2.1.3) atíṅ silfd ##  
 mágáral ya # in anák #(#) karfn kiṅ silfd  
*'There is a room.'*  
*'The child is studying there in the room.'*

Now, the second occurrence of silfd renders it -new. kiṅ silfd may therefore be deleted:

(3.2.2.1.2.1.3') mágáral ya # iṅ anák #(#) karfn  
*'The child is studying there.'*

Or, one may say:

(3.2.2.1.2.1.3'') atíṅ silfd ##  
 pipágarálan ne niṅ anák (# iṅ silfd)  
*'There is a room.'*  
*'The room is being studied in by the child.'*

where the location N in the second sentence is extra-posed and subjectivised, copied into  $V_2$  as \*ya, and then deleted because -new. The integration of the location N into the  $\overline{V_2}$  N configuration is now complete, since in surface structure, the configuration resembles as

$\overline{V}$     N    N configuration.

This process will be called 'Integrating Subjectivisation'; more examples of it will be given in subsequent sections. For this reason, no rule will be formulated at this juncture.

It might be objected that this way of viewing location N's is artificial and unnecessarily complicates semantic structure. Why not consider the location N in the example as just another accompanying N by specifying the action V as locative instead of postulating the location N as traceable to a separate state V? Pāṇini seemingly held this view, for he postulated adhikāraṇa 'place in which' as a basic kāraka relation.

There is no doubt that a location N accompanies the nuclear structure of certain non-state V's and even certain state V's which are not

specified as locative. For example, in the rules formulated in Chapter I, a presential state V may be optionally accompanied by a location N. Moreover, directional action V's are accompanied by a kind of location N insofar as a source or a goal N is a kind of location N. However, in sentences such as (3.2.2.1.2.1.3), the location N is clearly extraneous to the nucleus of the second sentence. To include a location N in a verb root such as *'to study'* would unduly complicate the semantic rules formulated in Chapter I, since as a result, any non-state V and many state V's can be specified as locative and then accompanied by a location N. Moreover, such a view would miss the clear parallelism between sentences (3.2.2.1.2.1.1) and (3.2.2.1.2.1.2).

A final word should be said about the symbolisation of oblique determiners in location N's. In Chapter II, symbolisation rules were given for oblique-marked demonstrative pronouns (the symbolisations of which were homophonous with oblique-marked demonstrative determiners):

kanítaŋ anák	<i>'to that child'</i>
kaníta	<i>'to that [one]'</i>

In the rules given, there were variant symbolisations for these oblique-marked demonstrative pronouns:

kanítaŋ anák	<i>'to that child'</i>
ké taŋ balé	<i>'to that house'</i>

kaníta is usually used with human N's but kéta occurs with any N (including human N's). What is interesting is that kéta is likewise a symbolisation for the locative proform *'there (neither near you nor me)'* unlike in English, where there is a distinction between *'that'* and *'there'* (and *'this'* and *'here'*). To cite the other types of demonstratives:

kaníniŋ anák	<i>'to this child (near me)'</i>
*ka+iní+ŋ baláy >	
kéniŋ balé	<i>'to this house (near me)'</i>
kéni	<i>'to this [place] near me = here'</i>
*ka+iyán+ŋ anák >	
kéŋ anák	<i>'to that child (near you)'</i>
kéŋ balé	<i>'to that house (near you)'</i>
kéŋ	<i>'to that [place] near you = there'</i>
kanítinŋ anák	<i>'to this child (near you and me)'</i>
*ka+ití+ŋ baláy >	
kétinŋ balé	<i>'to this house (near you and me)'</i>
kéti	<i>'to this place near you and me = here'</i>

Besides *kéta*, *kéni*, *kén*, and *kéti*, there is another locative proform *karfn* 'there yonder' which is analysable as '-proximate to speaker, -proximate to hearer, distal'. 'Distal' is a new specification hitherto not discussed in connection with demonstratives. It is necessary to account for *karfn* and for *nandfn* 'earlier on the same day', a temporal proform (to be discussed in the next section). *karfn* and *nandfn* are unusual since there is no subject form for these demonstratives.

### 3.2.2.1.2.2. Temporal

#### 3.2.2.1.2.2.1. Temporal Idioms

Consider the following sentence:

(3.2.2.1.2.2.1.1) *búkas # in pistá*  
'The fiesta [will take place] tomorrow.'

where there is a V . Other temporal verb roots are *nápun* 'yes-  
state  
temporal  
future  
tomorrow

*terday*' (lit. *late afternoon* + preteritiviser), *nábéni* 'last night' (lit. *night* + preteritiviser), *póta* 'later'. Aside from such inherently temporal verb roots, time is likewise indicated in Pampangan by a non-lexically specified temporal state V accompanied by a time N with the root *aldó* < \**aldáw* 'day' (lit. *sun*) and/or spatial units.

It is perhaps a language universal that time is expressed in terms of spatial units such as 'proximate to speaker' and 'proximate to hearer'. What is interesting is the degree to which Pampangan exploits the dimensions of space to express different temporal categories. To account for such temporal state V's expressed in spatial units, post-semantic literalisation rules whereby semantic units of time are replaced by semantic units of space will be needed. These time semantic units are idioms (following Chafe's definition of idioms) and must be literalised by matrices of spatial units. Like other idioms, temporal idioms present special problems which must be noted in the lexicon.

To express 'today' (for the purposes of this analysis, 'today' will be characterised as  $\left[ \begin{array}{l} \text{-past} \\ \text{-future} \\ \text{specific} \end{array} \right]$ , where 'specific' is paraphrasable as

'specific day'), there are alternative ways:

(3.2.2.1.2.2.1.2) *infn aldó a inf # in pistá*  
'The fiesta [will take place on] this day.'

where 'on this day' is literalised as *sun* .  
definite  
demonstrative  
proximate to speaker  
SUBJECT

The post-semantic process of demonstrative copying (formulated in Chapter II) must likewise be applied. One can likewise say:

(3.2.2.1.2.2.1.2') itŋ aldó a itf # iŋ pistá  
'The fiesta [will take place on] this day,'

where now 'on this day' is literalised as

sun
definite
demonstrative
proximate to speaker
proximate to hearer
SUBJECT

It is not clear whether there is a difference in meaning between itŋ aldó a inf and itŋ aldó a itf; in my idiolect, they are genuine variants, but it could very well be that in some other dialect, the former would have the added specification 'immediate'.

Still a third way of expressing 'on this day' is:

(3.2.2.1.2.2.1.2") ġéniŋ aldó a inf # iŋ pistá  
'The fiesta [will take place on] this day.'

where now the literalisation is

sun
definite
demonstrative
proximate to speaker
-SUBJECT
-OBLIQUE

To express [past  
-specific], one says:

(3.2.2.1.2.2.1.3) kétaŋ aldó # iŋ pistá  
'The fiesta [took place] on that  
sun neither near you nor me.' =  
'The fiesta [took place] at some  
point in the past.'

where the literalisation is

sun
definite
demonstrative
OBLIQUE

. If one wanted to be

specific, one would say:

(3.2.2.1.2.2.1.3a) itán aldó a itá # iŋ pistá  
'The fiesta [took place on] that  
specific day in the past.'

where now the literalisation is

sun
definite
demonstrative
SUBJECT

and where the process of

demonstrative copying must likewise be applied. A variant of the preceding sentence is

(3.2.2.1.2.2.1.3a') kέtaη aldó a itá # iη pistá  
*'The fiesta [took place] on that  
 specific day in the past.'*

where, instead of SUBJECT, 'sun' is OBLIQUE, with the usual demonstrative copying process.

To express  $\left[ \begin{array}{l} \text{future} \\ \text{specific} \end{array} \right]$ , one would say:

(3.2.2.1.2.2.1.4) kέη aldó a iyán # iη pistá  
 iyán aldó a iyán # iη pistá  
*'The fiesta [will take place] on  
 that specific day.'*

where the literalisation is *sun*  
 definite  
 demonstrative  
 proximate to hearer  
 SUBJECT/OBLIQUE

Other temporal idioms do not use the lexical unit 'sun' but N without lexical specification:

(3.2.2.1.2.2.1.5) ηέni # iη pistá  
*'The fiesta [is taking place] presently.'*  
*'The fiesta [will take place] today.'*  
*'The fiesta [took place] today.'*

Note that ηέni is unmarked as to time; a preceding linguistic context will have to specify the time. 'Today' is literalised as

N . The same symbolisation ηέni is likewise used  
 definite  
 demonstrative  
 proximate to speaker  
 -SUBJECT  
 -OBLIQUE

for 'right now' which may be characterised as  $\left[ \begin{array}{l} \text{-future} \\ \text{-past} \\ \text{specific} \\ \text{immediate} \end{array} \right]$  while

'today' is characterisable as  $\left[ \begin{array}{l} \text{-future} \\ \text{-past} \\ \text{specific} \end{array} \right]$ . To emphasise the notion

of 'immediate', the Spanish loanword mismo 'same' is added:

(3.2.2.1.2.2.1.6) ηέni mismú # iη pistá  
*'The fiesta [is taking place] right now.'*

To express 'earlier on the same day' another non-lexically specified N is used:

(3.2.2.1.2.2.1.7) nandfn # iq pistá  
 'The fiesta [took place] earlier today.'

The temporal juncture referred to by 'earlier on the same day' is difficult to fit into the sub-system of contrasting temporal dimensions described thus far without introducing uneconomical distinctions. Perhaps a simpler alternative would be to consider 'earlier on the same day' an idiom literalised by N . The unit 'distal' has

definite  
 demonstrative  
 distal  
 -SUBJECT  
 -OBLIQUE

already been introduced in connection with karfn 'there yonder'.

To express 'during daytime', the lexical unit 'sun' is used once more:

(3.2.2.1.2.2.1.8) néq aldó # iq pistá  
 'The fiesta [takes place] during daytime.'

where the idiom is literalised as sun  
 definite  
 demonstrative  
 proximate to hearer  
 -SUBJECT  
 -OBLIQUE

In the sentence

(3.2.2.1.2.2.1.9) indát búlan # iq pistá  
 'The fiesta [takes place] each month.'

the time N is literalised as moon . indát is used to symbolise  
 definite  
 individuated  
 SUBJECT

'each' and is used in expressing temporal recurrence.

Undoubtedly, there are many more such idioms. The following literalisation rules are by way of illustration. They show that although spatial dimensions are exploited to express temporal dimensions, the correspondences are ad hoc and not completely regular:

## (T ) Temporal to Spatial Literalisation Rule I

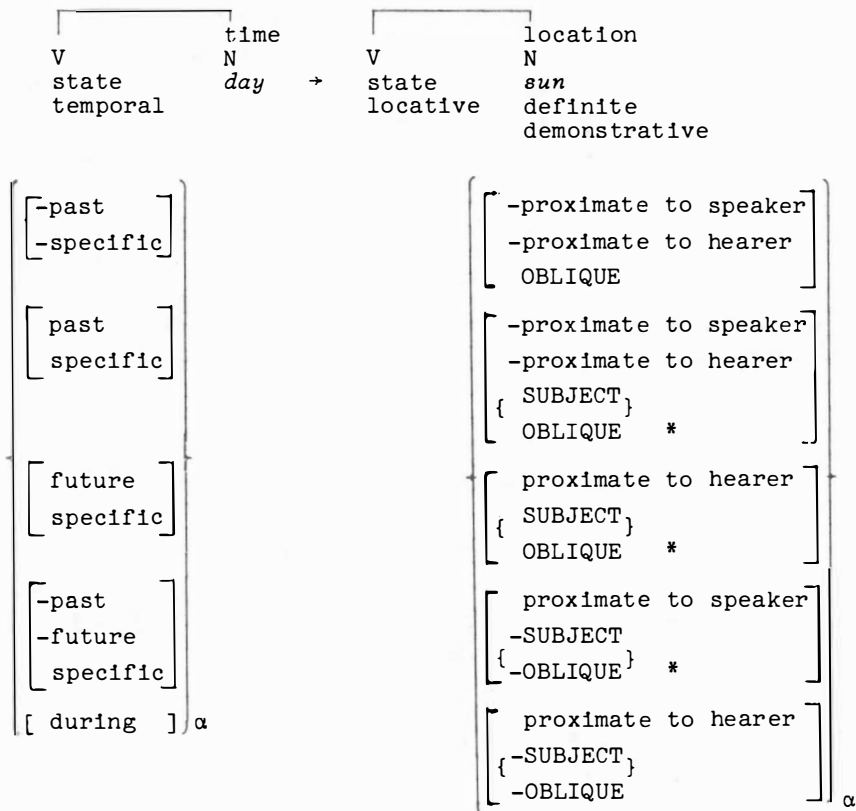

\*The Demonstrative Copying Rule must likewise be applied.

## (T ) Temporal to Spatial Literalisation Rule II

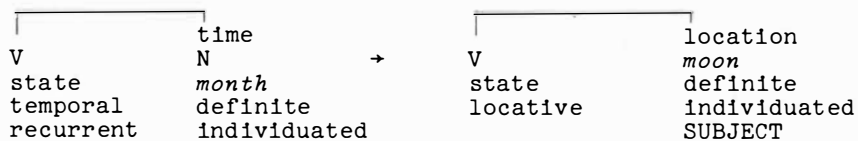

(T ) Temporal to Spatial Literalisation Rule III

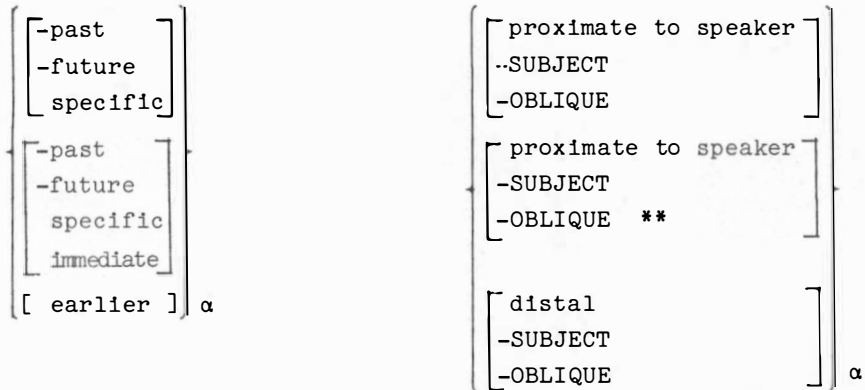
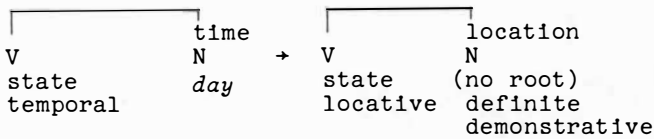

\*\*This particular matrix likewise requires the addition of an emphatic specification symbolised by the Spanish loanword mismo.

3.2.2.1.2.2.2. Adverbial Phrases of Time

Consider the sentence:

(3.2.2.1.2.2.2.1) ketaη aldó a itá # in pistá  
 'The fiesta [took place] on that specific day.'

the semantic structure of which may be represented thus:

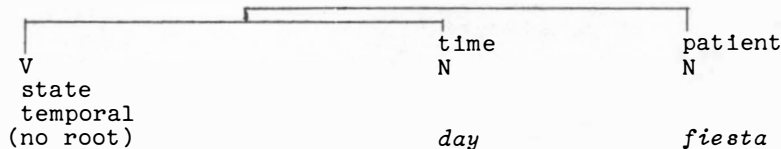

Now a state V which is temporal may be predicated not only of a patient N but of a V N configuration in a patient relation to the temporal state V:

(3.2.2.1.2.2.2.2) ketaη aldó a itá #(#)  
 migpistá ya # | Pédru  
 'On that specific day Pedro held a celebration.'

where the semantic structure is

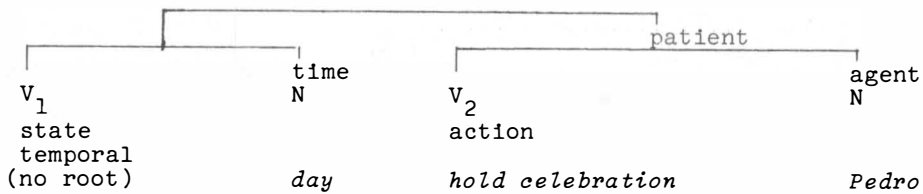

As with locative state V's which are not lexically specified, the temporal state V is post-semantically deleted. In turn, the patient sub-structure undergoes the usual processes of subjectivisation and incorporation. The time N may be post-posed:

(3.2.2.1.2.2.2.2') migpistá ya # i Pédrú #(#)  
kétan aldó a itá

Or the time N may be interposed between V<sub>2</sub> and the subject:

(3.2.2.1.2.2.2.2'') migpistá ya #(#) kétan aldó a itá #(#) i Pédrú

Or if the time N is TOPIC:

(3.2.2.1.2.2.2.2.2a) kétan aldó a itá ya migpistá # i Pédrú  
'It was on that specific day that Pedro held  
a celebration.'

It should be noted that the above sentence, following the literalisation rules earlier set down, may likewise be expressed by:

(3.2.2.1.2.2.2.2''') itán aldó a itá #(#) migpistá ya # i Pédrú

where the occurrence of two subject N's is another cogent confirmation of the claim that the time N in this sentence is somehow unintegrated with the rest of the sentence. The two subject N's corroborate the hypothesis that the structure is originally a  $\overline{V}$  V structure.

Consider the sentence sequence:

(3.2.2.1.2.2.2.2.3) kasayá na nin aldó a itá ##  
pípagpistán neñ Pédrú (# itán aldó a itá)  
'How happy that specific day was!'  
'That specific day was feasted in by Pedro.'

In the first sentence, 'that specific day' is a non-subject patient N. The sentence following has the same semantic structure as (3.2.2.1.2.2.2.2); however, because the time N is -new, it is extraposed and subjectivised, with the incorporated time subject marker pipag-...-an added to the verb root. This process is similar to the one described in the section on locative adverbs as 'Integrating Subjectivisation', so that in effect,

what was semantically a  $\overline{V \quad V}$  configuration (with the second V embedded) becomes in surface structure at  $\overline{V \quad \overline{N \quad N}}$  configuration, with the time N subjectivised.

### 3.2.2.1.2.2.3. Aspectual Harmony

If the proposed analysis of time adverbs is accepted, namely, that traditional adverbs of time are actually state temporal V's predicated of an embedded  $\overline{V \quad N}$  configuration, then aspectual harmony rules whereby the specifications of  $V_1$  constrain the aspectual specification of  $V_2$  must likewise be posited.

If  $V_1$  is future,  $V_2$  must be -actual:

(3.2.2.1.2.2.3.1)  $k\acute{e}n \acute{l}\acute{u}n\acute{i}s \#(\#) \acute{m}ak\acute{o} \acute{y}a \# \acute{i} \acute{P}\acute{e}dru$   
'Next Monday Pedro will leave.'

If  $V_1$  is past,  $V_2$  cannot be -actual:

(3.2.2.1.2.2.3.2)  $k\acute{e}t\acute{a}\eta \acute{l}\acute{u}n\acute{i}s \#(\#) \acute{m}\acute{e}k\acute{o} \acute{y}a \# \acute{i} \acute{P}\acute{e}dru$   
'Last Monday Pedro left.'

(3.2.2.1.2.2.3.3)  $k\acute{e}t\acute{a}\eta \acute{l}\acute{u}n\acute{i}s \#(\#) \acute{m}\acute{a}m\acute{a}k\acute{o} \acute{y}a \# \acute{i} \acute{P}\acute{e}dru$   
'Last Monday Pedro was leaving.'

If  $V_1$  is neither past nor future, there seem to be no constraints on aspectual specification of  $V_2$ :

(3.2.2.1.2.2.3.4)  $\eta\acute{e}n\eta \acute{l}\acute{u}n\acute{i}s \acute{a} \acute{i}n\acute{f} \#(\#) \acute{m}ak\acute{o} \acute{y}a \# \acute{i} \acute{P}\acute{e}dru$   
'On this Monday [today] Pedro will leave.'

(3.2.2.1.2.2.3.5)  $\eta\acute{e}n\eta \acute{l}\acute{u}n\acute{i}s \acute{a} \acute{i}n\acute{f} \#(\#) \acute{m}\acute{a}m\acute{a}k\acute{o} \acute{y}a \# \acute{i} \acute{P}\acute{e}dru$   
'On this Monday [today] Pedro is leaving [presently].'

(3.2.2.1.2.2.3.6)  $\eta\acute{e}n\eta \acute{l}\acute{u}n\acute{i}s \acute{a} \acute{i}n\acute{f} \#(\#) \acute{m}\acute{e}k\acute{o} \acute{y}a \# \acute{i} \acute{P}\acute{e}dru$   
'On this Monday [today] Pedro left.'

(3.2.2.1.2.2.3.7)  $\eta\acute{e}n\eta \acute{l}\acute{u}n\acute{i}s \acute{a} \acute{i}n\acute{f} \#(\#) \acute{k}al\acute{a}k\acute{o}l\acute{a}k\acute{o}$   
 $na \acute{p}\acute{a} \acute{m}\acute{u}\eta \acute{P}\acute{e}dru$   
'On this Monday today Pedro has just now left.'

The semantic rules for aspectual harmony may be formulated thus:

(S )  $V_2 \leftrightarrow$  -actual /  $V_1$   
future

(S )  $V_2 \leftrightarrow$  actual /  $V_1$   
past

A sentence such was

(3.2.2.1.2.2.3.8) *mámakó ya # i Pédrú*

may be translated in English as

*'Pedro is leaving.'*

*'Pedro was leaving.'*

In Pampangan, it is unmarked for time. The whole event may be located in time only by a preceding temporal state V uttered earlier in the discourse or obvious from the context of situation.

A seeming exception to the aspectual harmony rules formulated in the sentence sequence:

(3.2.2.1.2.2.3.9) *nápun #( # ) mámakó ya sána # i*

*Pédrú ## óneŋ ## dínatán ya #*

*in kapatád na ## é ne méko ##*

*'Yesterday Pedro intended to leave*

*but his brother came.'*

*'He did not leave anymore.'*

Problematic is the sentence *makó ya sána # i Pédrú* 'Pedro intended to leave' where V is -actual, although  $V_1$  is temporal past. It was stated earlier that if  $V_1$  is past,  $V_2$  must always be actual. The cause for the apparent irregularity is the presence of the semantic unit 'intended to'. Such units will be treated at greater length in Chapter IV. It seems that the semantic structure of the sentence in question is:

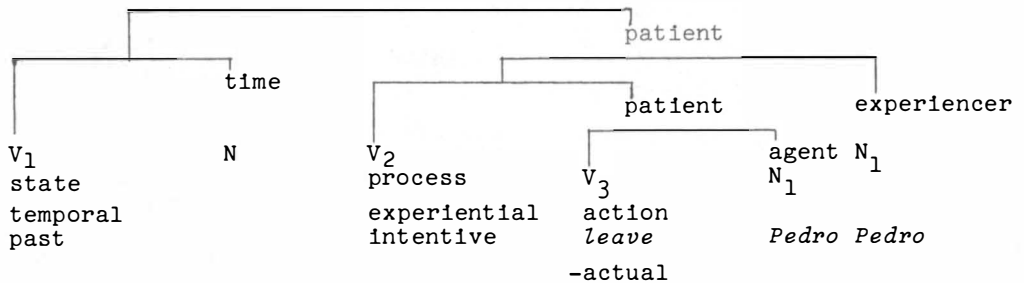

The occurrence of past in  $V_1$  locates the whole patient sub-configuration in past time. However, the earlier rule on the necessity of a V subordinate to a past  $V_1$  to be aspectually actual seems to apply to an immediately subordinated or dominated  $V_2$ . In this instance, the immediately dominated  $V_2$  is not 'leave' but a non-lexically specified  $V_2$  'intentive'. Hence, the fact that 'leave' is not aspectually specified as 'actual' is not really irregular, since it is  $V_2$  and not  $V_3$  which must be actual. Eventually, of course,  $V_3$  is deleted, but not

before incorporating 'intensive' into  $V_3$  which is eventually symbolised by *sána*. In a more adequate grammar, the earlier Aspectual Harmony Rule formulated must be made quite explicit concerning its area of dominance, namely, that the rule applies only to an immediately subordinated  $V_2$ .

Again, consider another apparent irregularity:

- (3.2.2.1.2.2.3.10) *kéŋ óras a dátaŋ ka #(#) méŋan ná ku*  
*x'On that hour near you that you shall*  
*arrive, I already ate.'* =  
*'On the hour when you shall arrive, I shall*  
*already have eaten.'*

The example seems to violate the earlier stipulation that if  $V_1$  is future,  $V_2$  must be -actual; in this case, *méŋan* 'ate' is actual completed instead of the expected -actual. The semantic structure of the sentences may be represented thus:

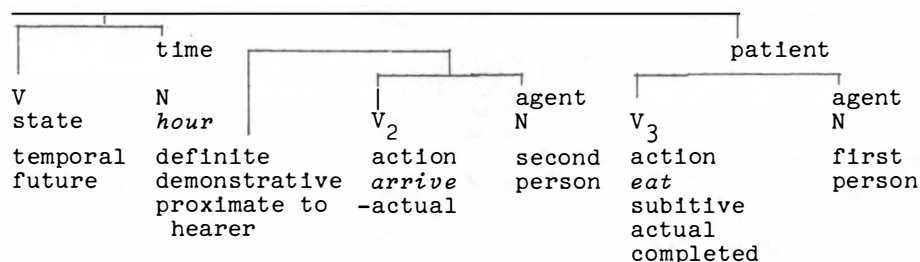

The clause '*when you shall arrive*' may be looked upon as specifying '*hour*' further; it is not directly related to the state V but to the time N. The whole configuration including the patient sub-configuration is located in future time because of  $V_1$ ; however, it seems that only  $V_2$  is subject to the Aspectual Harmony Rule earlier formulated: it must be -actual. Again, therefore, the above example is not an irregularity; what is necessary is to explicitly state the domain of the Aspectual Harmony Rule.

Tense-aspect relations demand separate treatment. No doubt, more constraints will be found as more structures are analysed. It seems, however, that in such analysis, the notion of '*domain*' and '*what is immediately dominated*' or at least linked immediately to another temporal state V, become very relevant.

### 3.2.2.1.2.3. Benefactive

Consider the sentence:

(3.2.2.1.2.3.1) pará kiη anák ya # iη digálu  
 'The gift is [intended] for the child.'

where pará is from Spanish para 'for', which has been assimilated into the language. It serves to make explicit the notion of 'intended for', 'for the sake of', 'for the benefit of'. The structure for the above sentence may be represented thus:

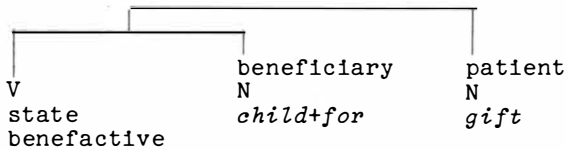

Now, it is possible for a benefactive state V to be accompanied not only by a patient N but a whole  $\overline{V \quad N}$  configuration in a patient-like relation to V:

(3.2.2.1.2.3.2.) pará kiη anák #(#) lálákad ya # i Pédru  
 'For the benefit of the child Pedro is walking.'

The structure of the sentence may be represented thus:

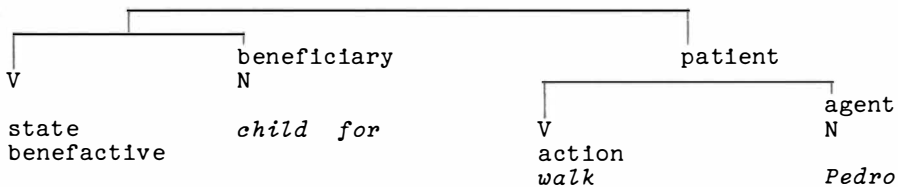

Since  $V_1$  is not lexically specified, it is post-semantically deleted.  $V_2$  undergoes the usual post-semantic processes of subjectivisation and incorporation. The beneficiary N may be post-posed:

(3.2.2.1.2.3.2') lálákad ya # i Pédru #(#) pará kiη anák  
 'Pedro is walking for the benefit of the child.'

Or it may be interposed between  $V_2$  and the agent N:

(3.2.2.1.2.3.2'') lálákad ya #(#) pará kiη anák #(#) i Pédru  
<sup>x</sup>'Pedro for the benefit of the child is walking.'

If the beneficiary N is TOPIC, it must be pre-posed:

(3.2.2.1.2.3.2a) pará kiη anák ya lálákad # i Pédru  
 'It is for the benefit of the child that  
 Pedro is walking.'

Consider now the sentence sequence:

- (3.2.2.1.2.3.3) kainá na niη anák † ##  
 páglákad neη Pédro (# iη anák)  
 x 'How weak the child is.'  
 'Pedro is walking for the benefit of the child.'

In the second sentence, the beneficiary N, which is -new, is integrated into the embedded  $V_2$  N configuration by being extra-posed and subjectivised after  $V_1$  has been deleted.

It should be noted that the beneficiary N in the second sentence is extraneous to the meaning of the sentence 'Pedro is walking'; there is nothing in the meaning of 'to walk' to imply a beneficiary N whereas a beneficiary N is demanded by an intrinsically benefactive root such as 'to give'. It is possible to undergo any process or to perform any action for the sake of somebody, in which case the configuration would be

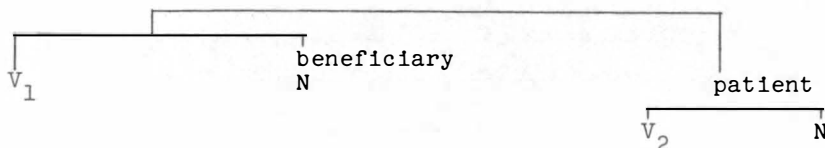

but it is only a relatively restricted subset of verb roots which is intrinsically benefactive and demands an accompanying beneficiary N, in which case the configuration would be

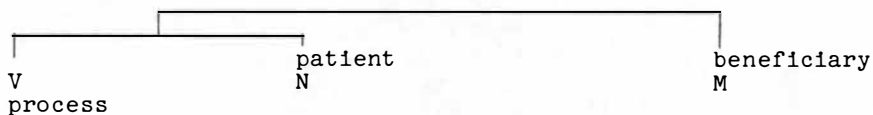

or

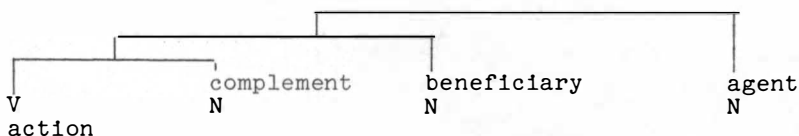

It should be noted too that the usual marker for the incorporated subject specification in the verb root for structures of the first type is pag- whereas the usual marker for the incorporated subject specification in the verb root for structures of the second type is  $\emptyset$  and for structures of the third type, -an:

- (3.2.2.1.2.3.4) máñailáñan yaη péra # iη anák  
 'The child is needing money.'

- (3.2.2.1.2.3.5) dirínAN neḡ digáluḡ Pédrú # iḡ anák  
*'The child is being given a gift by Pedro.'*

Finally, in contemporary Pampangan, unless the beneficiary N in configurations of the first type is subject, the non-subject beneficiary N phrase must always occur with Spanish loanword *pará* (this is not true for structures of the second and third type):

- (3.2.2.1.2.3.6) lálákad ya # i Pédrú #(#) pará kiḡ anák  
<sup>x</sup>lálákad ya # i Pédrú #(#) kiḡ anák

The sentence marked <sup>x</sup> is acceptable, but it means *'Pedro is walking towards the child'*.

#### 3.2.2.1.2.4. Motivative

Consider the sentence:

- (3.2.2.1.2.4.1) kiḡ pistí # iḡ sakít  
*'The sickness [is due] to the pestilence.'*

where a motivative state V is presicted of a patient N:

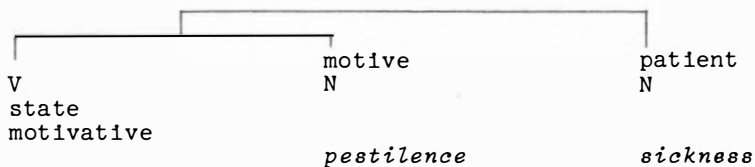

Instead of an ordinary patient, one may have an embedded  $\overline{V}$  N configuration in a patient relation to the motivative state V:

- (3.2.2.1.2.4.2) kiḡ pistí #(#) mamamaté la # diḡ manúk  
*'Because of the pestilence the chickens are dying.'*

The semantic structure may be represented thus:

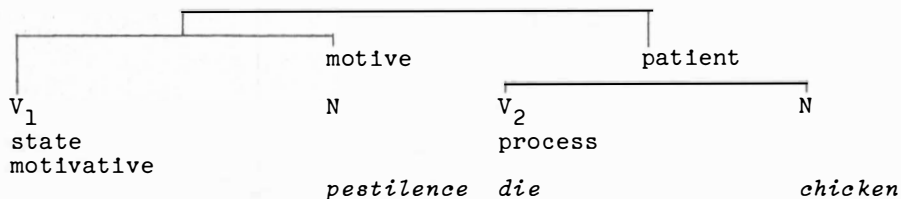

Since  $V_1$  is not lexically specified, it is eventually deleted; the embedded configuration undergoes the usual post-semantic processes of subjectivisation and incorporation. It is possible for the motive N to be post-posed to yield the preferred variant:

- (3.2.2.1.2.4.2') mamamaté la # diḡ manúk #(#) kiḡ pistí  
*'The chickens are dying because of the pestilence.'*

Or the motive N may be interposed between  $V_2$  and the patient N:

- (3.2.2.1.2.4.2") mamamaté la #(#) kiŋ pistí #(#) diŋ manúk  
*'The chickens, because of the pestilence,  
 are dying.'*

Again, it is possible to have the sentence sequence:

- (3.2.2.1.2.4.3) atíŋ pistí ##  
 akakamaté da diŋ manúk # iŋ pistí  
*'There is a pestilence.'*  
*'The pestilence [is the occasion/motive for]  
 the chickens dying.'*

Thus, the motive N, which is -new, may be extra-posed and then subjectivised, in effect integrating the motive N into the embedded  $\overline{V_2}$  N configuration by an Integrating Subjectivisation Process. Since pistí is -count, it is not copied into  $V_2$ ; probably because there is no copier in  $V_2$ , the -new noun phrase iŋ pistí is not deleted in this instance.

It is possible for the motivative state V to be lexically specified:

- (3.2.2.1.2.4.4) úli na niŋ pistí #(#) mamamaté la# diŋ manúk  
*'By reason of the pestilence the chickens are  
 dying.'*

úli is problematic as to etymology. It is probably the same root found in \*m+uif? 'to return to one's point of origin' = 'to go home' and hence is best considered a noun root meaning 'origin'. Hence, in the above, it seems to be a predicate noun, origin + predicativiser. It is likewise unusual insofar as its accompanying motive N (ordinarily post-semantically OBLIQUE) is always -SUBJECT and -OBLIQUE and copied into the predicate noun as na. It is likewise possible to say:

- (3.2.2.1.2.4.4') mamamaté la # diŋ manúk #(#) úli na niŋ pistí  
*'The chickens are dying by reason of the pestilence.'*

It is, however, not possible to interpose the phrase 'by reason of the pestilence' between  $V_2$  and the patient N.

It is possible for the embedded  $\overline{V_2}$  N to be any sub-type of V:

- (3.2.2.1.2.4.5) úli mu #(#) masantíŋ ya # iŋ balé  
*'By reason of you the house is pretty.'*
- (3.2.2.1.2.4.6) úli na niŋ páli? #(#) mándílu ya # iŋ anák  
*'By reason of the heat the child is bathing.'*

Since state V's do not allow a choice in subjectivisation, the integrating subjectivisation process cannot apply to (3.2.2.4.5). However, it is possible with action V's to say:

- (3.2.2.1.2.4.6a) akakadflu na niη anak # iη páli?  
*'The heat [is the occasion/motive for]  
 the child bathing.'*

In this case, it seems that the root must be deleted first before integrating subjectivisation can take place. Moreover, with action and process-action V's, unless the motive N is subjectivised, it is not possible for the motive N to occur without úli. Thus, it is not possible to say:

- (3.2.2.1.2.4.6b) <sup>x</sup>mandilu ya # iη anak #(#) kiη pali?  
*'The child is bathing by reason of the heat.'*

whereas it is possible to say

- (3.2.2.1.2.4.7) mamamaté ya # iη anak #(#) kiη páli?  
*'The child is dying by reason of the heat.'*

### 3.2.2.1.2.5. Integrating Subjectivisation

The last four sections on locative, temporal, benefactive, and motive structures had this in common: traditional adverbs of place and of time and adverbial phrases of benefaction and motivation were treated as arising from separate state V's predicated of an embedded  $\overline{V \ N}$  configuration in a patient-like relation to the state V. In each case, the semantic structure was:

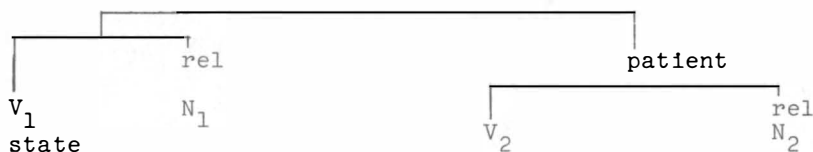

For structures such as the above, ordering of the post-semantic rules is crucial. Since the embedded  $\overline{V_2 \ N}$  patient is -definite, it is neither subjectivised nor copied, but rel N<sub>1</sub> is marked OBLIQUE. Then V<sub>1</sub> is deleted because not lexically specified, yielding the configuration:



If N<sub>1</sub> is -new, its root may be deleted and the N<sub>1</sub> branch directly symbolised by a pronoun (the rel of N<sub>1</sub> are all eventually marked OBLIQUE and hence, even if not lexically specified, are not deleted but symbolised directly by oblique-marked pronouns) or N<sub>1</sub> may be extra-posed:

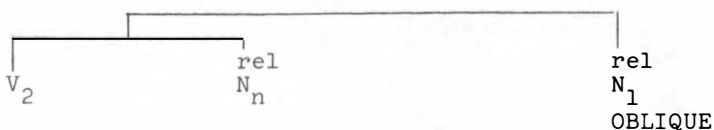

Once extra-posed, N<sub>1</sub> may be subjectivised and incorporated into V<sub>2</sub>. The incorporated subject specifications (eventually symbolised by affixes added to the verb root) arising from what originally in semantic structure were  $\overline{V} \quad \overline{V}$  configurations seem to constitute a subset by themselves and should be marked in some way. Eventually, they are symbolised as:

- pipag-...-an 'location subject'
- aka- 'time subject'
- pipag-...-an
- pag- 'beneficiary subject'
- aka- 'motive subject'
- ka-...-an

On the other hand, in V configurations where location, time, or motive is subject (only in state V's), the incorporated marker for subject choice is  $\emptyset$ ; in V configurations where beneficiary N is subject, it is  $\emptyset$  for state and process V's and -an for action and process-action V's.

Thus, no new post-semantic processes need be posited other than a new extra-position rule (which applies after the deletion of V<sub>1</sub>):

(T ) Extraposition Rule

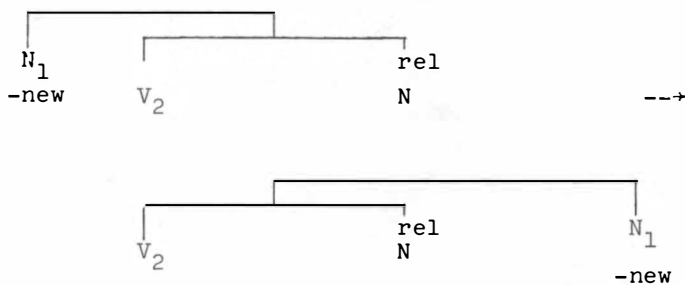

3.2.2.2. Other Structures

Many of the configurations to be discussed in this section have been treated in the transformational generative grammar literature as instances of complementation. Within the frame of reference adopted in this study, such complementation arises from the same type of embedded  $\overline{V} \quad \overline{N}$  configurations already discussed; typically, however, the matrix

sentence in such embeddings manifests a configuration more complex than the configurations hitherto described.

### 3.2.2.2.1. Embeddings in V experiential

Consider the following sentence:

(3.2.2.2.1.1) burf naŋ Pédrú #(#) iŋ makó ya # i Suán  
'The [fact that] Juan will leave is liked by Pedro.'

where the clause 'Juan will leave' is the patient in an experiential state V and where Pédrú is the experiencer N:

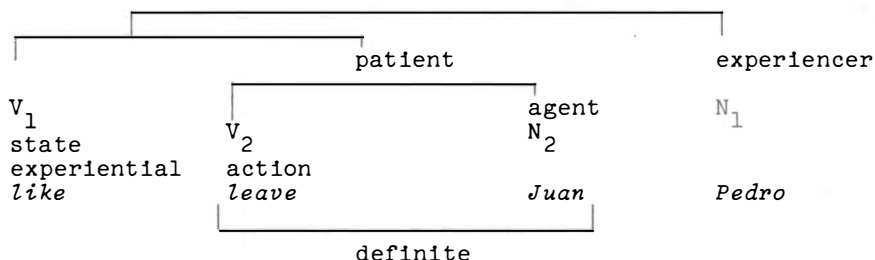

The whole patient sub-configuration is inflected as definite. Because the patient is definite, it must be extra-posed and eventually subjectivised; the subject, however, is abstract and is not copied into  $V_1$ . By a later process, the determiner may be deleted, to yield the more common variant:

(3.2.2.2.1.1.1) burf naŋ Pédrú #(#) makó ya # i Suán

Alternatively, instead of deletion, SUBJECT may be shifted to OBLIQUE, to yield the equally common:

(3.2.2.2.1.1.1") burf naŋ Pédrú #(#) kiŋ makó ya # i Suán  
'[To the effect that] Juan will leave  
is liked by Pedro.'

The prior specification of patient as SUBJECT as a context for deletion or shift is necessary to account for the fact that the experiencer is -SUBJECT and -OBLIQUE; the unmarked subject of experiential V's is the experiencer N.

Where the embedded  $\overbrace{V_2 \ N}$  has been subjectivised, there are no aspectual restrictions on  $V_2$ , so that one can have the following:

(3.2.2.2.1.2)\* burf? na naŋ Pédrú #(#) iŋ dátaŋ ya # i Suán >  
burf naŋ Pédrú #(#) iŋ dátaŋ ya # i Suán  
'The fact that Juan will arrive is liked by Pedro.'

- (3.2.2.2.1.3) burf naŋ Pédru #(#) iŋ dínatán ya # i Suán  
'The [fact that] Juan arrived is liked by Pedro.'
- (3.2.2.2.1.4) burf naŋ Pédru #(#) in dáratán ya # i Suán  
'The [fact that] Juan is arriving [right now] is liked by Pedro.'
- (3.2.2.2.1.5) burf naŋ Pédru #(#) in karatán datán na pá muŋ Suán  
'The [fact that] Juan has just now arrived is liked by Pedro.'

It is not necessary, however, that the patient be definite. If patient is -definite, the sub-configuration is not extra-posed and subjectivised but remains -SUBJECT and -OBLIQUE; since it is likewise -definite, the determiner is  $\emptyset$ . In configurations where the patient is -definite, one of the embedded N's is always co-referential with one of the matrix N's and is eventually deleted. Thus:

- (3.2.2.2.1.6) bÍsa yaŋ makó # i Suán  
'Juan wants to leave.'

where the configuration is

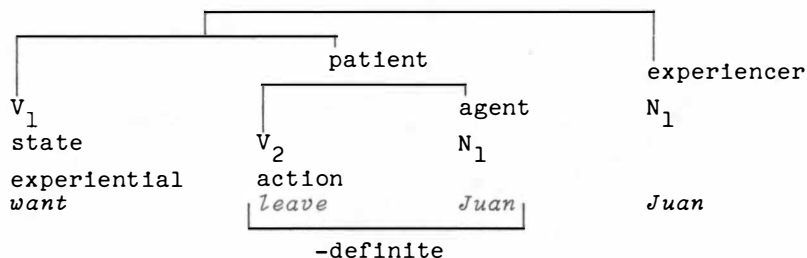

The embedded  $N_1$  is -new and deleted, leaving the configuration

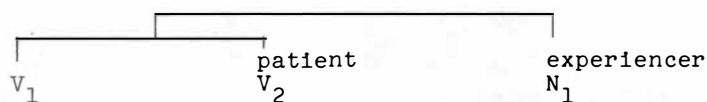

The experiencer N is subjectivised and copied into  $V_1$ ; since the patient is -SUBJECT and -OBLIQUE, it is likewise incorporated into  $V_1$ , thus yielding a surface structure

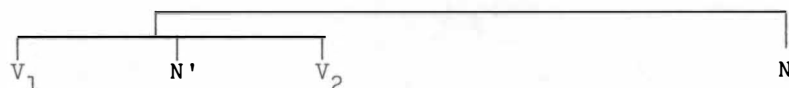

Note that the surface structure of the sentence parallels the surface structure of sentences with manner adverbs and frequency or instance adverbs (see section 3.2.1). Another requirement of the above configuration is that  $V_2$  is always unmarked for aspect.





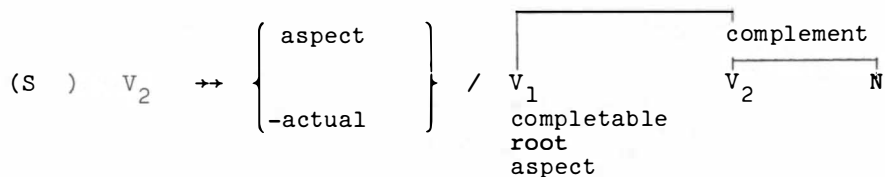
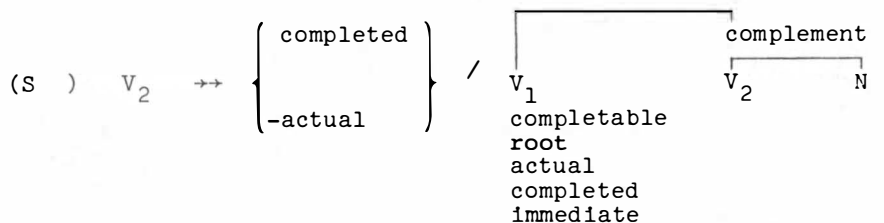

(The two rules are disjunctively ordered with regard to each other; if the first one applies, the second one cannot apply.)

### 3.2.2.2.3. Embeddings in V

action  
verbal  
completable

Consider the sentence:

(3.2.2.2.3.1) sasabiyán nañ Pédrú #(#) in makó ya kanú # i Suán  
'The [event that] Juan will reportedly leave  
is being said by Pedro.'

where the structure is

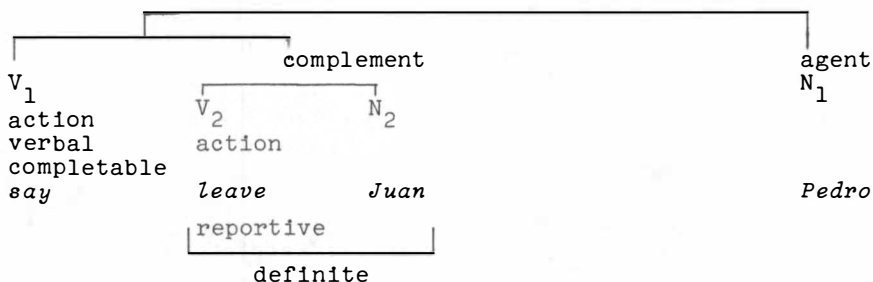

kanú, the symbolisation of 'reportive', is optional and is used only in structures of this type; since what is said is always definite (it refers to a definite utterance earlier said by someone in the context of discourse), a completable verbal action V is always accompanied by a subjectivised complement. Hence, the complement is extra-posed and subjectivised; since it is abstract, it is not copied into V<sub>1</sub>. If there is an N in the embedding which is co-referential with an N in the matrix, it must be deleted:

(3.2.2.2.3.2) sasabiyán nañ Pédrú #(#) iñ makó ya kanú (# i Pédrú)  
*'The [event that] he [Pedro] will reportedly  
 leave is being said by Pedro.'*

Sentence (3.2.2.2.3.1) has the following more common variants:

(3.2.2.2.3.1') sasabiyán nañ Pédrú #(#) makó ya kanú # i Suán

(3.2.2.2.3.1") sasabiyán nañ Pédrú #(#) kiñ makó ya kanú # i Suán

Hence, the specifications 

definite
SUBJECT

 may eventually be deleted or SUBJECT may be shifted to OBLIQUE.

With reported speech, which is always extra-posed, there are no restrictions on aspectual specification. Unlike in English, indirect statements do not necessitate aspectual (or tense) changes in the embedded V to make aspect (or tense) harmonise with the V of the matrix sentence.

It is possible to delete  $V_1$  and the agent N if they are -new, to yield:

(3.2.2.2.3.1a) makó ya kanú # i Suán  
*'Juan will reportedly leave.'*

In such a case, kanú is not optional, since it is the only clue left that the original statement was once part of a configuration, the complement in fact, of a verb of speaking.

There is an interesting verbal activity root in Pampangan symbolised as ñá which is completely unspecified for aspect and which always deletes the SUBJECT determiner or shifts SUBJECT to OBLIQUE:

(3.2.2.2.3.3) ñá nañ Pédrú #(#) (kiñ) makó ya kanú # i Suán  
*'[To the effect that] Juan will reportedly leave  
 is being said by Pedro.'*

So far, only indirect statements have been exemplified: questions have not been dealt with. Questions will be treated at great length in Chapter IV; anticipating the discussion in Chapter IV, embedded questions will be exemplified:

(3.2.2.2.3.4) kukután nañ Pédrú #(#) nuñ nánánu ya kanú # i Suán  
*'What Juan is reportedly doing is being asked  
 by Pedro.'*

Again, the unit 'reportive' symbolised by kanú is optional; it seems that the extra-posed complement is not subjectivised (there is no -an affixed to the verb root; -an is the usual marker for complement subject choice); moreover, nuñ is phonologically similar to nañ/niñ, the -SUBJECT and -OBLIQUE determiner. nuñ is likewise a symbolisation for 'if'.

Direct quotations present no unusual features. The unit 'reportive' does not occur; there are no pro-nominal shifts. Like indirect quotations, direct quotations may be extra-posed and subjectivised, although the determiner must be deleted. In fact, no determiner is possible and the full sentential boundary marker (##) is maintained:

- (3.2.2.2.3.5) sasabiyán nañ Pédro ## makó ku  
 '[It] is being said by Pedro: "I will leave".'

The complement may be marked TOPIC and pre-posed:

- (3.2.2.2.3.5a) makó ku ## sasabiyán nañ Pédro  
 "'I will leave", it is being said by Pedro.'

3.2.2.3. Nominalisation

Consider the sentences:

- (3.2.2.3.1) máyap #(#) ñ lálákad ya # i Pédro  
 'The [fact that] Pedro is walking is good [to hear].'  
 (3.2.2.3.2)\* máyap #(#) ñ pá+mag+lákad na nañ Pédro >  
 máyap #(#) ñ pámaglákad nañ Pédro  
 'The act of walking by Pedro by Pedro is good.' =  
 'Pedro walks all right.'

The semantic structure of the first sentence has already been analysed in section 3.2.2.1.1 as

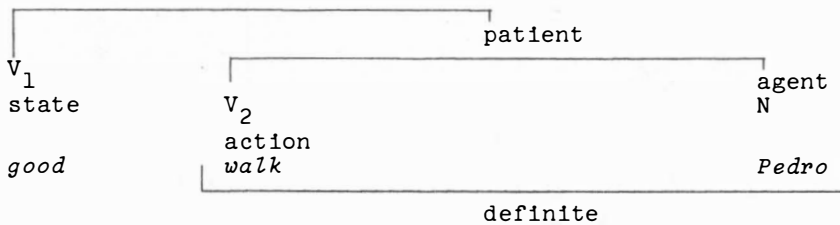

On the other hand, the semantic structure of the second sentence (after some post-semantic processes have applied) seems to be

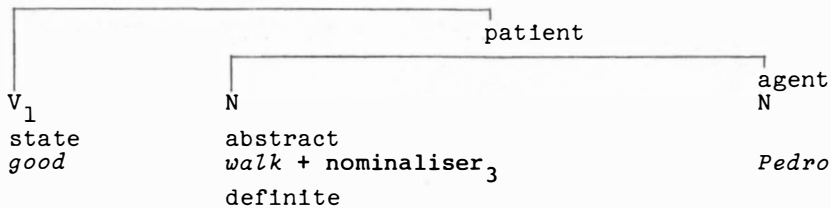

Obviously the two structures are related. At the same time, there is clearly a distinction between '*the fact that Pedro walks*' and '*the act of walking by Pedro*'. Semantically, therefore, the initial structure of the second sentence must reflect this semantic difference, presuming that all semantic information must be indicated in the initial structure. It would not do, therefore, to state that the first structure becomes the second structure (in the transformational generative grammar literature, this process was labelled 'nominalisation'; see Lees 1960); rather the representation of the two structures must show their sameness and at the same time their difference. I propose that the initial semantic configuration of the second sentence is:

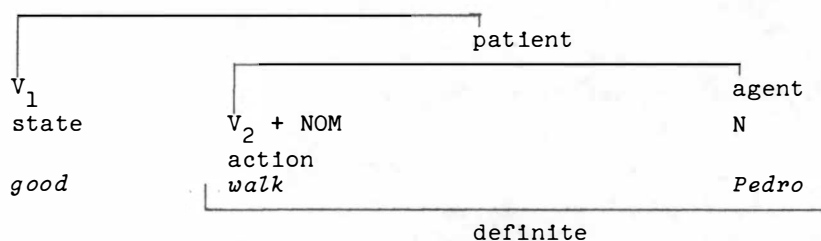

The occurrence of NOM (for 'nominalised') triggers a post-semantic process replacing the patient sub-configuration with:

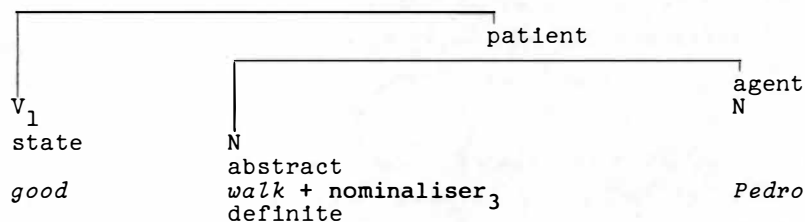

Since the nominal N is definite, it is subjectivised but not copied into  $V_1$  (since it is abstract); the agent N, since it is not SUBJECT, is -SUBJECT and -OBLIQUE; by a process already described for  $\overline{N \quad N}$  configurations, agent N is copied into abstract N as  $n_a$ , thus generating the surface structure:

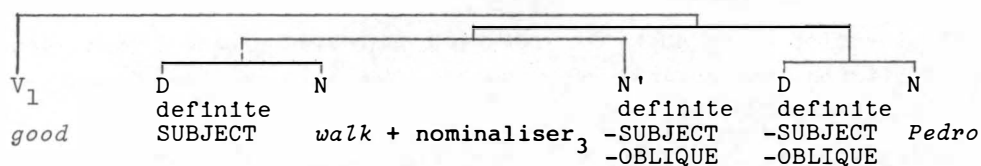

As the process has been described, it is possible to generate a nominal even in initial discourse. Typically, however, nominals arise

in the context of discourse when a preceding  $\overline{V}$   $\overline{N}$  structure is repeated as an embedded  $\overline{V}$   $\overline{N}$  structure in a subsequent sentence:

- (3.2.2.3.3) lálákkad ya # in anák ##  
 ákákkit nan Pédro #(#) in pámaglákkad na nin anák  
 'The child is walking.'  
 'The act of walking by the child is being seen by Pedro.'

Instead of nominalising, however, the language performer may focus on the fact that the child is walking:

- (3.2.2.3.3a) ákákkit nan Pédro #(#) (kin) lálákkad ya # in anák  
 '[To the effect that] the child is walking is  
 being seen by Pedro.'

Nominals are considered abstract and hence are never copied into V; moreover, they are always definite. Hence, a nominal in surface structure must always be marked by in, kin, or if -SUBJECT and -OBLIQUE, nin. The following examples will clarify this:

- (3.2.2.3.4) masantín ya # in anák ##  
 mákayáma #(#) in kasantiñán na nin anák  
 'The child is pretty.'  
 'The prettiness of the child is motivative of pleasure.'
- (3.2.2.3.5) dáragúl ya # in anák ##  
 mákayáma #(#) in páñaragúl na nin anák  
 'The child is growing.'  
 'The growing of the child is motivative of pleasure.'
- (3.2.2.3.6) lúluksú ya # in anák ##  
 mákayáma #(#) in pámagluksú na nin anák  
 'The child is jumping.'  
 'The jumping by the child is motivative of pleasure.'
- (3.2.2.3.7) púpútut yan dútuñ # in anák ##  
 mákayáma #(#) in pámagpútut nañ dútuñ nin anák  
 'The child is cutting wood.'  
 'The cutting of wood by the child is motivative of  
 pleasure.'

In the examples given above of different nominals arising from various verb sub-types, the nominal was SUBJECT. The next two examples show the nominal as -SUBJECT:

- (3.2.2.3.8) matúla ya # i Suán #(#) kin pámagpútut nañ dutuñ nin anák  
 'Juan is full of amusement from the cutting of wood  
 by the child.'

- (3.2.2.3.9) péte ne niḡ pámaglákad # i Pédrú  
*'Pedro died from the act of walking (e.g.,  
because of a weak heart).'*

When a verb root is nominalised, its aspect specifications are deleted:

- (3.2.2.3.10) ífnakad ya # i Pédrú  
íkit naḡ Suán # nápun #(# ) iḡ pámaglákad naḡ Pédrú  
*'Pedro walked.'*  
*'The act of walking by Pedro was seen by Juan yesterday.'*

However, a nominal retains the other inflectional specifications of its verb root (as well as any derivational units attaching to the basic root):

- (3.2.2.3.11) pálákad yaḡ opisína # i Pédrú ##  
burf naḡ Suán #(# ) iḡ pámagpalákad naḡ opisínaḡ Pédrú  
*'Pedro is managing [an] office.'*  
*'The managing by Pedro of an office is liked by Juan.'*

where the derivational unit pa 'causativiser' is carried into the nominal.

- (3.2.2.3.12) máḡlákad ya # i Pédrú ##  
mákabuisít #(# ) iḡ pámaḡlákad naḡ Pédrú  
*'Pedro walks repeatedly.' = 'Pedro walks to many places.'*  
*'The walking by Pedro to many places is motivative  
of irritation.'*

where the frequentative marker maḡ- is carried into the nominal.

- (3.2.2.3.13) puputútAN ne niḡ anák # iḡ dútuḡ ##  
mákayáma #(# ) iḡ páMípútut na niḡ anák kiḡ dútuḡ  
*'The [piece of] wood is being cut by the child.'*  
*'The act of cutting the [piece of wood] by the child  
is motivative of pleasure.'*

In the preceding sentence, the subject marker -an is not carried over into the nominal but the influx -mI- seems to symbolise a different subject choice since the usual nominal for 'cutting' (with unmarked agent subject) is pámagpútut. Note, too, the shift in the determiner of the former subject (iḡ to kiḡ: SUBJECT to OBLIQUE); the shift is unusual insofar as a patient N is usually not specified as OBLIQUE.

It is possible not only for a  $\overline{V} \quad \overline{N}$  configuration to be nominalised but likewise a  $\overline{V} \quad \overline{\overline{V}} \quad \overline{N}$  configuration:

- (3.2.2.3.14) maralás yaḡ lúluksú # iḡ anák  
*'The child jumps often.'*

Either one of the V's in the  $\overbrace{V \quad V}$  configuration above may be nominalised. If *maralás* is nominalised, two structures are possible:

- (3.2.2.3.14a) *é máyap #(#) iŋ karalásan naŋ lúluksú niŋ anák*  
 (3.2.2.3.14a') *é máyap #(#) iŋ karalásan naŋ pámagluksú niŋ anák*  
*'The frequency of jumping by the child is not good.'*

On the other hand, if *lúluksú* is nominalised, only one output is possible:

- (3.2.2.3.14b) *é mayap #(#) iŋ pámagluksú naŋ maralás niŋ anák*  
*'The frequent jumping by the child is not good.'*

There is thus pressure in nominalisation to nominalise the main verb *luksú* even when the adjunct state verb *maralás* is the locus of nominalisation; indirectly, this seems to be a confirmation of the peripheral character of the adverb with regard to the rest of the sentence.

In general, the symbolisations for nominalisation are:

V state		
root + NOM	→	ka+root+án
patient subject		
V process		
root + NOM	→	páŋa+root
patient subject		
V (process) action		
root + NOM	→	pámag+root
agent subject		
V (process) action		
root + NOM	→	pámi+root
-agent subject		

Where the verb root has a derivational unit attached to it, the derivational unit is included, preceded by the nominalising prefix:

mipaglútu?	pá+mipaglútu?	'reciprocative cooking'
makilútu?	pá+makilútu?	'associative cooking'
makipaglútu?	pá+makipaglútu?	'participative cooking'
misábi	pá+misabi	'mutual speaking' = 'agreement'

Lexical idiosyncracies in the symbolisation of nominalised forms would have to be stated by lower level symbolisation rules.

## 3.2.3. Relativisation

## 3.2.3.1. Restrictive Clauses

## 3.2.3.1.1. Relative Clauses with State V

Consider the sentence:

(3.2.3.1.1.1) masantfŋ ya #(#) iŋ balé a maputí?  
 'The house [which] is white is pretty.'

The semantic structure of the sentence may be represented thus:

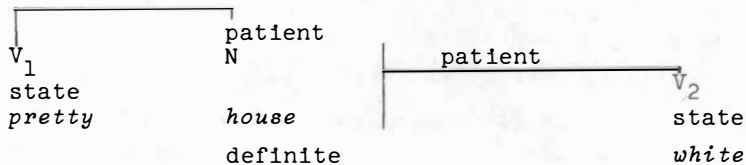

$V_1$ , a state V, is accompanied by a patient N, which in turn seems to be further specified as a white house. Clearly,  $V_2$  is subordinate to  $V_1$ ; on the other hand, the patient N stands in a patient relation to the state  $V_2$ . As the representation above attempts to show,  $V_2$  specifies the house (which is definite) as white. The information 'white' is something added to 'house'; it is not necessary for the lexical choice of 'house', although 'white' serves to identify which house. The attachment of the  $V_2$  line to the perpendicular line to the right of 'house' is meant to convey this inflectional type of specification. On the other hand, definite is specified of the whole N sub-configuration including its attached V. N is in a patient relation to both V's.

If one accepts the proposed representation as an adequate one for the semantic structure of the sentence, the post-semantic processes necessary are relatively simple. The patient N is subjectivised and copied into  $V_1$ . Unlike the analysis proposed in the literature on relative clauses emanating from transformational generative grammarians, this analysis needs no deletion process. In English, there would be need of a copying process to account for WH-forms. In Pampangan, there is no need for either a deletion or a copying process, only the incorporation of  $V_2$  into the N branch to account for the occurrence of the linker a/-ŋ. Thus, the surface structure of the sentence would be:

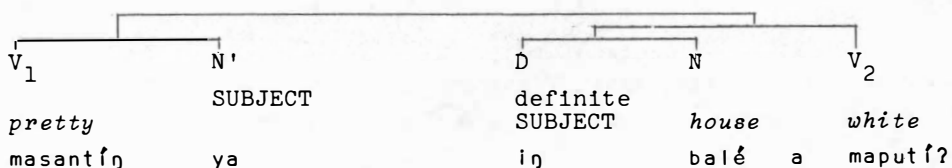

A later process, an optional one, may interpose  $V_2$  between D and N:

(3.2.3.1.1.1) masantfŋ ya # iŋ maputfŋ balé

Besides simple state V's like maputi? 'white', other state V's may occur in inflectional specification to an N. State V's which are not further specified account for traditional adjectives. Instead of an ordinary state V, however, one may have a state V further specified as locative, temporal, possessive, or partitive. These types of state V's are not lexically specified but demand another accompanying N in addition to a patient N:

(3.2.3.1.1.2) masantfŋ ya # iŋ balé kiŋ atbá  
'The house [which] is in the field is pretty.'

where the semantic structure may be represented as

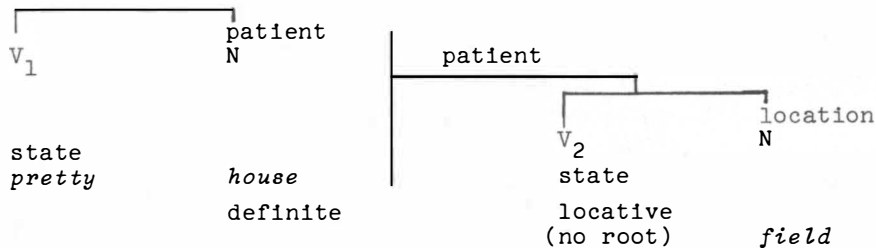

Again, the N 'house' occurs in a patient relation to both  $V_1$  and  $V_2$ . Since  $V_2$  is not lexically specified, it is post-semantically deleted, and the resulting configuration undergoes the same processes already described for adjectives in relative clauses except that in surface structure, instead of  $V_2$ , one has an oblique-marked (location) N instead.

(3.2.3.1.1.3) masantfŋ ya # iŋ sfne kétaŋ lúnis  
'The movie [which was shown] on Monday was nice.'

where the semantic structure may be represented as

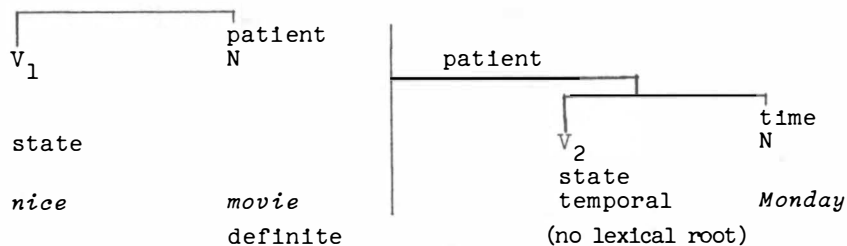

Possessive and partitive state V's show the same type of semantic structure (but require other post-semantic processes):

(3.2.3.1.1.4) masantíŋ ya # iŋ balé na niŋ anák  
 'The house [which belongs to] the child is pretty.'

(3.2.3.1.1.5) masantíŋ ya # iŋ sálas na niŋ balé  
 'The living-room [which is part] of the house is pretty.'

The semantic structures of the two sentences may be represented thus:

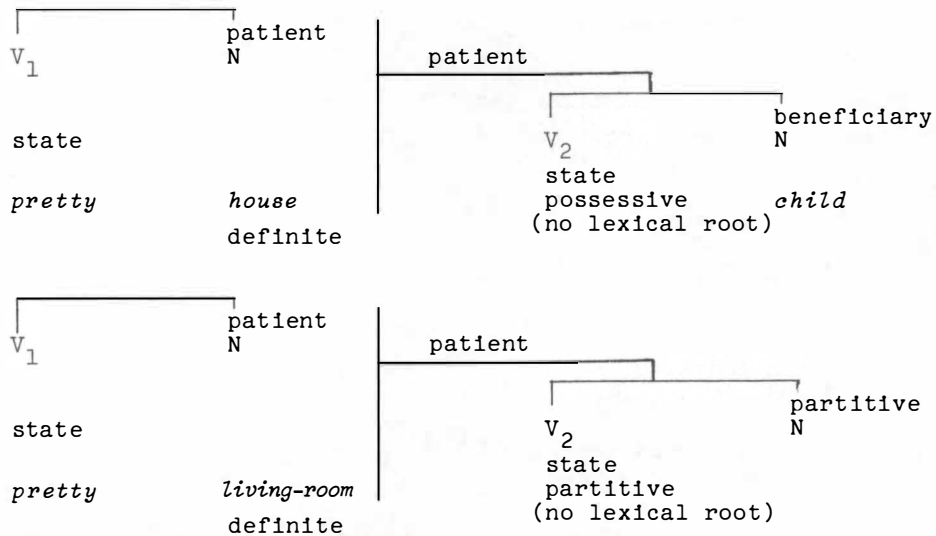

Since  $V_2$  is not lexically specified, it is post-semantically deleted; in turn,  $N_2$  is attached to  $N_1$ , yielding a sub-configuration:



Following rules set down in Chapter II, such configurations provide the context for the following processes: OBLIQUE specification for beneficiary/partitive N is shifted to -OBLIQUE; the beneficiary/partitive N is then copied into  $N_1$  as na.

It is interesting to note that in surface structure, the following noun phrases appear as having the same structure although they arise from three different types of subordinate state V's:

iŋ balé na niŋ anák	'The house [which belongs to] the child'
iŋ sálas na niŋ balé	'The living-room [which is part] of the house'
iŋ pámaglákad na niŋ táu	'The act of walking by the man'

In such  $\overline{N \quad N}$  structures, it is possible to delete the second N (beneficiary/agent) if it is -new or if it is obvious from the non-linguistic context:

iŋ balé na	'The house [which belongs to] him = his house'
iŋ sálas na	'The living-room [which is part] of it = its living-room'
iŋ pámaglákad na	'The act of walking by him = his act of walking'

On the other hand, it is likewise possible to delete the first N root if it is -new or obvious from the non-linguistic context (note the accent on the determiner):

íŋ kiŋ anák	'That [which belongs] to the child'
íŋ kiŋ balé	'That [which is part of] the house'
íŋ kiŋ táu	'The [action which is being performed by] the man'

To generate the above structures, however, it seems that the deletion must take place before the OBLIQUE shift; once one no longer has an  $\overline{N \quad N}$  structure, the context for the OBLIQUE to -OBLIQUE shift no longer obtains. Moreover, it is possible to delete the root of the second N of the first and third examples above (but not of the second), in effect pro-nominalising the OBLIQUE N:

íŋ kayá	'That [which belongs] to him
íŋ kayá	'The [action which is being performed by] him'

### 3.2.3.1.2. Relative Clauses with Non-State V

Consider the sentence:

- (3.2.3.1.2.1) masíβag ya # iŋ táuŋ púpútut dútuŋ  
'The man [who] is cutting wood is industrious.'

where the semantic structure may be represented as

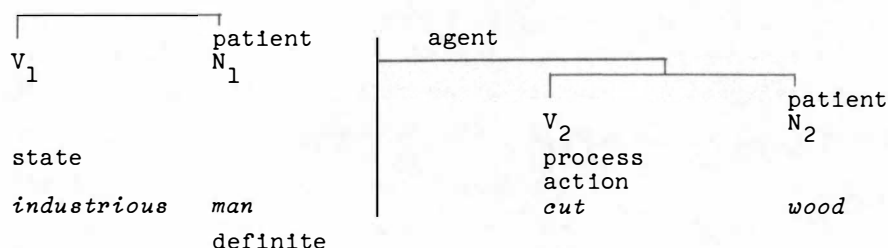

The structure is interesting insofar as it shows possibilities hitherto not discussed. Note that '*man*' is a patient N in relation to V<sub>1</sub> but an agent N in relation to V<sub>2</sub>; '*definite*' specifies the whole patient sub-configuration (including the attached V<sub>2</sub> N). Moreover, the attached relative clause inflectionally specifies N<sub>1</sub> by identifying '*which man*'. Post-semantically, too, V<sub>2</sub> N must be incorporated into the N<sub>1</sub> branch to account for the occurrence of the linker -*ŋ* in *táu*.

It is likewise possible to say:

- (3.2.3.1.2.2) *maragú! ya # in dútuŋ a puputútan na niŋ táu*  
*'The [piece of] wood [which] is being cut by*  
*the man is big.'*

where the semantic structure is:

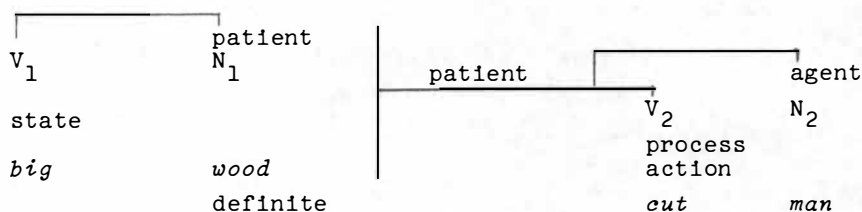

What is interesting about the above sentence is that V<sub>2</sub> is marked by the affix -*an*, the patient subject marker if V<sub>2</sub> were an independent structure. In other words, there is an agreement relation between matrix N<sub>1</sub> and its attached (or dependent) V<sub>2</sub>. Other than having no subject (what would have been its subject is in the matrix V configuration, where it need not be subject), V<sub>2</sub> is post-semantically treated like any ordinary V. Since it has no object, it receives no copier *ya* but its accompanying -SUBJECT and -OBLIQUE agent N is copied into it as *na*.

Returning now to sentence (3.2.3.1.2.1), one may have the sentence:

- (3.2.3.1.2.1a) *masípag ya # in táuŋ púpútut kiŋ dútuŋ*  
*'The man who is cutting the [piece of] wood*  
*is industrious.'*

It was stated in Chapter II that the patient N is usually -definite; if it were definite, it would have to be subjectivised. Semantically, 'wood' in the above sentence is definite: there is a particular piece of wood being referred to. On the other hand, definite patient N cannot be subjectivised since the attached  $\overline{V \quad N}$  configuration has no subject; moreover, if this attached  $\overline{V \quad N}$  configuration had a subject, as it now stands, it would be the agent N. Pampangan solves the dilemma, as it were, by shifting -OBLIQUE to OBLIQUE and marking 'wood' by *kiŋ*.

The examples given thus far show a restrictive relative clause attached to a subject N in the matrix sentence. This need not be the case, however; the only context necessary for a restrictive clause is that it be definite and that its attached  $\overline{V \quad N}$  sub-configuration serve to identify which N is being spoken of. Thus, one may have the sentence:

- (3.2.3.1.2.3) *biniyé ne niŋ táuŋ makuáita # kiŋ babáyiŋ malagú? #*  
*iŋ áutuŋ séli na (niŋ táu)*  
*'The car [which] was bought (by the man) was given*  
*by the man [who] was rich to the woman [who] was*  
*pretty.'*

### 3.2.3.1.3. Relative Clauses in Generic Statements

Consider the sentence:

- (3.2.3.1.3.1) *mikukuáita la # déŋ táuŋ mágóbraŋ masalése*  
*'Those men [who] work well grow rich.'*

where the semantic structure is:

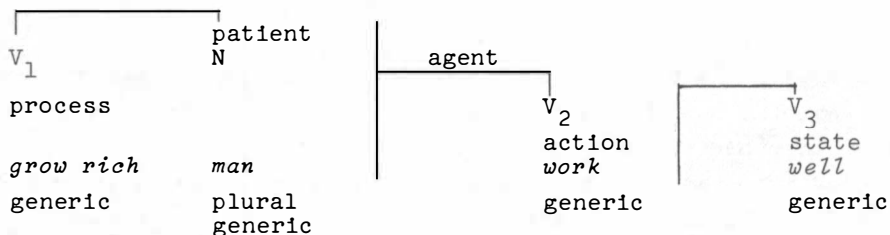

In the above sentence, as was shown for generic statements in Chapter I, the inflectional specification 'generic' of  $V_1$  characterises the rest of the structure as generic; the attached  $\overline{V_2 \quad V_3}$  configuration restricts 'men', namely, 'those who work hard'. 'Generic', as was shown in Chapter II, triggers post-semantic processes: 'generic' is replaced by  $\emptyset$  in state V's, by 'actual durative' in non-state V's; in

N's, plural generic is replaced by  $\left[ \begin{array}{l} \text{plural} \\ \text{demonstrative} \\ \text{proximate to hearer} \end{array} \right]$ . The cited sentence has a corresponding non-plural version:

(3.2.3.1.3.1a) mikukuáita ya # in táuṅ mágóbɔraṅ masalése  
'The man [who] works well grows rich.'

where the subject N is  $\left[ \begin{array}{l} \text{generic} \\ \text{aggregate} \end{array} \right]$ . The last example has a preferred variant in which  $V_1$ , instead of 'actual durative', is unmarked (-actual):

(3.2.3.1.3.1a') mikuáita ya # in táuṅ mágóbɔraṅ masalése  
'The man [who] works well will grow rich.'

### 3.2.3.2. Non-Restrictive Clauses

Consider the following sentence:

(3.2.3.2.1) mámaṅán yaṅ maṅgáṅ maslám # in anák  
'The child is eating [a] mango [which] is sour.'

where the semantic configuration is

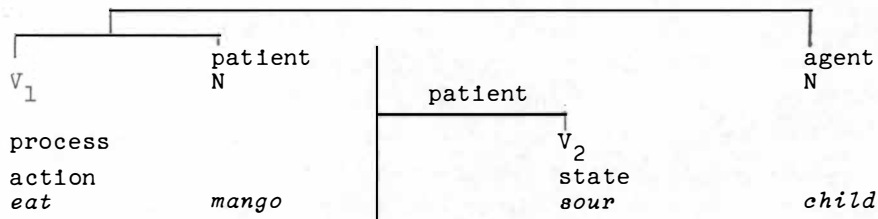

The patient N is -definite or unmarked. The state V 'sour' specifies the patient N further but is really non-essential to the patient N; it does not serve to identify maṅgá as a particular mango:

Consider now the sentence:

(3.2.3.2.2) dɪnatáṅ ya # i Pédrun maragú!  
'Big Pedro arrived.'

In the above sentence, the agent N is unique (and redundantly definite); it needs no further specification for identification. Presuming that the interlocutors know Pedro, the predication 'big' is redundant since it is known that Pedro is big (among his circle of acquaintances). What seems to obtain is that there is an optional selectional specification 'big' which is implied by *Pedro* and that this selectional specification may be highlighted by being copied as a separate V attached to N (in other words, a kind of relative clause). Thus, the

agent N may be characterised as

N
count
potent
animate
human
unique
(big+selectiviser)
<i>Pedro</i>
definite

The selectional unit '*big+selectiviser*', a derived unit from the inherent verb root '*big*', is a redundant specifier of '*Pedro*'. Its occurrence in the matrix is the context for a replacement process highlighting '*big*', so that the output of this replacement process yields the following semantic structure:

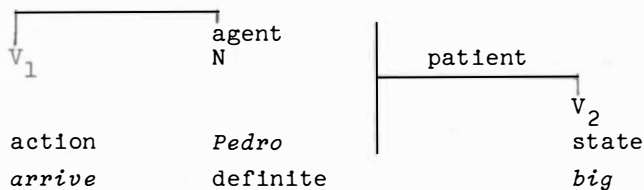

The lone N plays a dual role: it is an agent in relation to V<sub>1</sub> and a patient in relation to V<sub>2</sub>. Note that the perpendicular line to the right of '*Pedro*' extends to 'definite'; to this line is attached V<sub>2</sub>, an indication that V<sub>2</sub> further specifies an already fully specified definitised N matrix. The configuration calls for no additional semantic processes which have not already been discussed.

Some clauses which have been described in the traditional grammar handbooks as 'non-restrictive' are better described as parenthetical. For example, the following sentences seem to be genuine variants:

- '*John, who arrived yesterday, ate here.*'
- '*John (John arrived yesterday) ate here.*'
- '*John (he arrived yesterday) ate here.*'
- '*John - John arrived yesterday - ate here.*'
- '*John - he arrived yesterday - ate here.*'

To express similar sentences in Pampangan, one would say:

(3.2.3.3) méngan ya # kéni ## i Pédrúg dínatáŋ nápun

The above sentence is unnatural, however. It would be preferable to express the above sentence as two separate sentences or to topicalise Pédrú, utter the attached configuration parenthetically, and then say the rest of the sentence:

(3.2.3.3') méŋan ya # kéni # i Pédrú ##  
 dŋnatáŋ ya # nápun (# i Pédrú)  
 'Pedro ate here.'  
 'He arrived yesterday.'

(3.2.3.3'') i Pédrú ## dŋnatáŋ ya # nápun ##  
 méŋan ya # kéni  
 'As for Pedro - he came yesterday - he ate here.'

In any case, the clause 'he came here yesterday' is clearly peripheral to the rest of the sentence. In fact, a case can be made for considering both clauses 'John ate here' and 'John came here yesterday' as of equal rank, connected by a common agent N (the configuration below does not include the adverbs of time and of place, which would complicate the structure unduly):

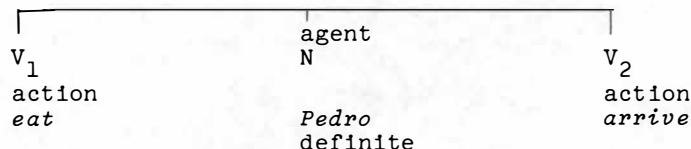

### 3.2.3.3. Deletion of Roots in N's with Relative Clauses

In section 3.2.3.1.1, examples were given of surface  $\overline{N \quad N}$  configurations in which the root of the first N was deleted, leaving only the determiner and the second N. In general, for all N's with an attached relative clause, it seems possible to perform a similar deletion, leaving only the determiner and the attached  $\overline{V \quad N}$  configuration. This seems to apply to both restrictive and non-restrictive clauses. Moreover, it is likewise possible to generate N's with attached relative clauses which are not lexically specified, if the referent of the lexical root is obvious from the non-linguistic context. The context for deletion is, of course, that already mentioned, namely, the specification -new. The outputs of either root deletion or non-lexical specification in such structures give rise to descriptive appellations.

(3.2.3.3.1) atí yu # iŋ táuŋ dŋnatáŋ  
 'The man [who] arrived is present.'

(3.2.3.3.1a) atí yu # iŋ dŋnatáŋ  
 'The [one who] arrived is present.'

(3.2.3.3.2) mikuáŋta ya ## iŋ táuŋ mágóbran masalése  
 'The man [who] works well will grow rich.'

- (3.2.3.3.2a) mikuálta ya ## in mágóbran masalése  
'The [one who] works well will grow rich.'
- (3.2.3.3.3) mámaḡán yaḡ mangḡán maslám # i Pédrú  
'Pedro is eating [a] mango [which] is sour.'
- (3.2.3.3.3a) mámaḡán yaḡ maslám # i Pédrú  
'Pedro is eating [something which] is sour.'
- (3.2.3.3.4) dínatán ya # i Pédrúḡ maragú!  
'Big Pedro arrived.'
- (3.2.3.3.4a) dínatán ya # i maragú!  
'Big [One] arrived.'

### 3.2.4. Summary

By way of summary, semantic rules (and relevant post-semantic rules) will be formulated to generate the structures discussed in section 3.2.

- (S )  $V_1$  root  $\rightarrow$   $V$  state  $V_1$  root
- (S )  $V_1$  process state  $\rightarrow$   $V_1$  patient  $V_2$
- (S )  $\begin{matrix} \text{rel} \\ V_2 \\ \text{root} \end{matrix}$  definite  $\rightarrow$   $\begin{matrix} \text{rel} \\ V_2 + \text{NOM} \\ \text{root} \end{matrix}$  definite /  $\begin{matrix} \text{rel} \\ V_1 \\ \text{rel} \\ V_2 \end{matrix}$

The preceding rule triggers a post-semantic process:

- (T )  $\begin{matrix} \text{rel} \\ V_2 + \text{NOM} \\ \text{root} \end{matrix}$  definite  $\rightarrow$   $\begin{matrix} \text{rel} \\ N \\ \text{root} + \text{nominaliser} \end{matrix}$  definite
- (S )  $\begin{matrix} \text{rel} \\ N \\ \text{-unique} \\ \text{root} \end{matrix}$  (definite)  $\rightarrow$   $\begin{matrix} \text{rel} \\ N \\ \text{-unique} \\ \text{root} \end{matrix}$  (definite)  $\begin{matrix} | \\ \text{rel} \\ \text{---} \\ V_2 \end{matrix}$

rel (N may be definite or -definite; it is always definite for restrictive clauses; if it is -definite, one type of non-restrictive clause is generated.)

(T ) rel  
 N  
 unique  
 verb root + selectiviser  
 root →  
 definite

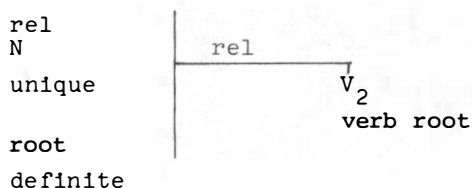

### 3.3. ILLUSTRATION

By way of summarising the whole chapter and to illustrate the different structures discussed in this chapter in the context of a larger structure, the following (admittedly contrived) sentence will be semantically analysed and post-semantic processes for its surface structure derivation suggested:

- (3.3.1) māsakft ya mán †# é ya man māsakft #  
 i Maryá ## b́sa yaŋ makiyábe # kiŋ pámpagpistá da  
 diŋ ának # kéŋ búlan a dárataŋ  
 'Whether Maria is sick or Maria is not sick,  
 she wants to join the festivities of the children  
 in the month which is coming.' =  
 'Whether or not Maria is sick, she wishes to join  
 the children's festivities next month.'

(māsakft 'sick' (lit. sickness + plenitiviser), man...é man 'whether or not', b́sa? 'in a state of wanting', makiyábe 'join' (lit. companion + associativiser), pámpagpistá 'festivities' (lit. fiesta + reciprocativiser + nominaliser<sub>3</sub>), ának 'children', búlan 'month' (lit. moon), dárataŋ 'come, arrive').

The semantic structure of the above sentence may be represented thus (specifications not relevant to the discussions of this chapter will not be included in the representation): (See overleaf.)

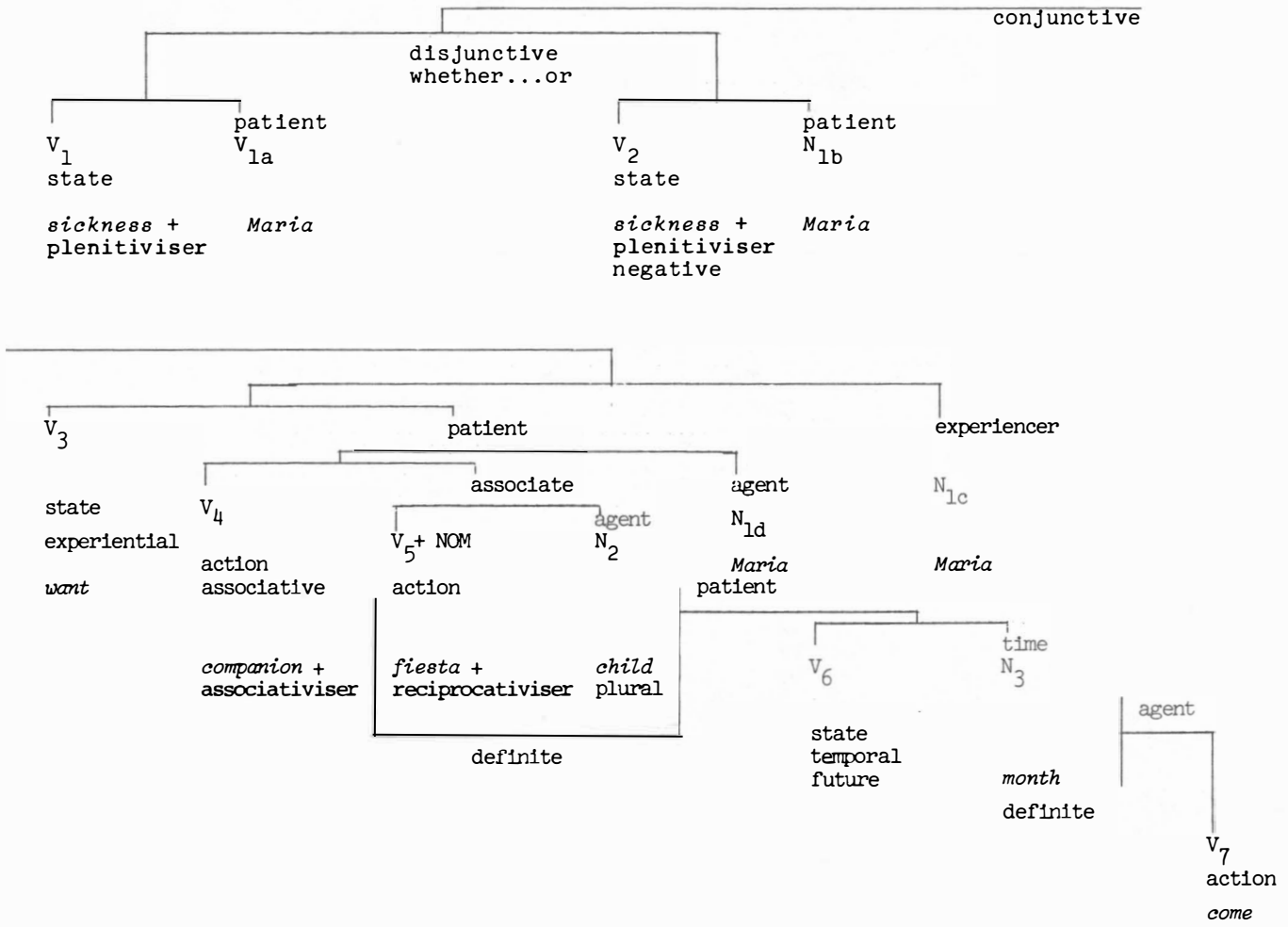

Basically, the sentence is a conjunction between a disjunctive statement and an ordinary statement. The conjunction is factual and not overtly marked. There is a pre-supposition that if Maria is sick, she is not expected to want to join the festivities; the sentence asserts the contrary: she does want to join. The linker for the disjunction is *man...man*, loosely translatable as '*whether...or*'. The second major clause consists of an experiential V which demands an experiencer N and a patient N, the latter the object of experience. Now the patient is an embedded  $\overline{V \quad N}$  configuration which consists of an associative action verb ( $V_4$ ) which in turn demands an accompanying agent N and an associate N. The associate N happens to be an abstract noun (an action root nominalisation) accompanied by an agent N. Of this nominalisation is predicated a temporal state verb ( $V_6$ ). The temporal state V is not lexically specified but is accompanied (in addition to the patient) by a time N which in turn has an attached relative clause ( $V_7$ ). To speak of '*month*' as '*coming*' is undoubtedly to speak metaphorically.

After the initial occurrence of '*Maria*' ( $N_{1a}$ ), all further occurrences of it are -new. By a convention, it will be postulated that post-semantic processes apply to the lowest V configuration. The post-semantic processes will then be applicable cyclically. There will thus be a total of seven cycles corresponding to the seven V's. The processes necessary for each cycle will be described informally.

- Cycle 1     Incorporation of  $V_7$  to the  $N_3$  branch
- Cycle 2     Specification of  $N_3$  as OBLIQUE  
              Deletion of  $V_6$
- Cycle 3     Replacement of  $V_5$ +NOM by Nominal  
              Specification of resulting Nominal as OBLIQUE  
              Incorporation of specifications of -SUBJECT and  
              -OBLIQUE  $N_2$  into Nominal
- Cycle 4     Deletion of  $N_{1d}$
- Cycle 5     SUBJECT specification of  $N_{1c}$   
              Incorporation of specifications of  $N_{1c}$  into  $V_3$   
              Incorporation of patient sub-configuration into  $V_3$   
              Deletion of  $N_{1c}$
- Cycle 6     SUBJECT specification of  $N_{1b}$   
              Incorporation of specifications of  $N_{1b}$  into  $V_2$   
              Deletion of  $N_{1b}$
- Cycle 7     SUBJECT specification of  $N_{1a}$   
              Incorporation of specifications of  $N_{1a}$  into  $V_1$

Linearisations (Major and Minor, including the post-posing of undeleted  $N_{1a}$  to the right of  $V_2$ ).

The resulting surface structure is:

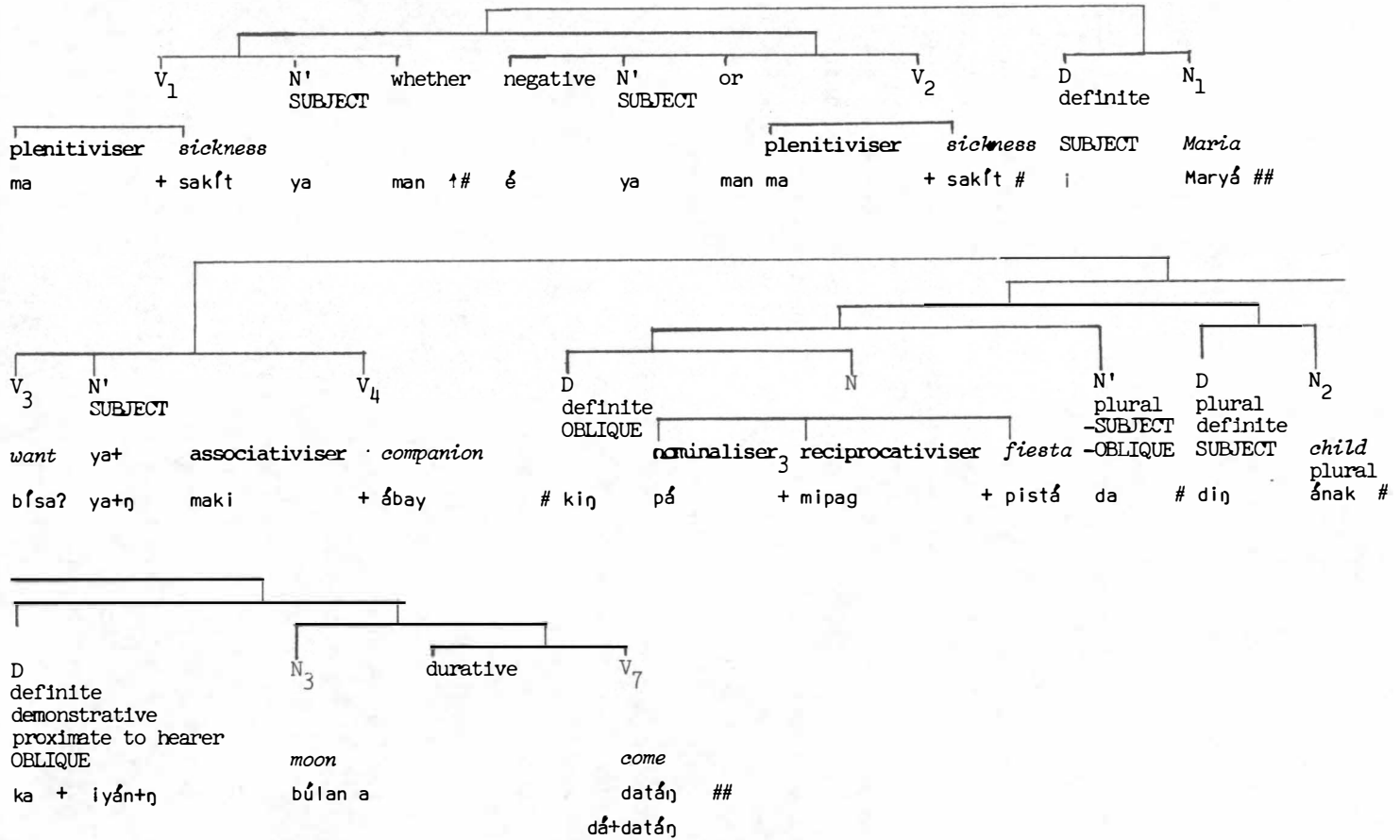

Phonetic representation

## másaklt ya mán # é ya man másaklt # i Maryá ## bfsa yaŋ makiyábe # kiŋ pá mipag pistá da (#) diŋ anak # kéŋ búlan a dáratán ##

## CHAPTER IV

### PRE-SEMANTIC STRUCTURES

#### 4. INTRODUCTION: THEORETICAL FRAMEWORK

The by-now traditional frame of reference proposed by Communication Theory will be taken as a starting point for the discussion of topics in this chapter.

Every communication event, every instance of a speech act, presupposes a Speaker (Voice) and a Hearer (Addressee) and a Message. The whole area of reality, of which Speaker and Hearer form a part, is codable; the actual message, however, expresses only what has been actually coded.

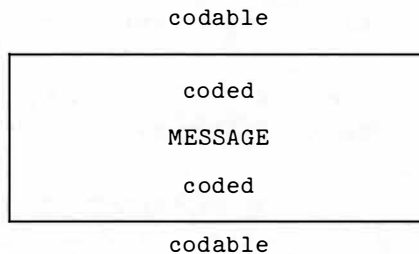

What is coded, of course, concerns language directly; it is the structure on the content side of the code which constitutes the subject matter of this study, that is, the content side of a particular code.

It seems, however, that one cannot discuss the area of the message or of what is coded, without taking into account the adjacent area of the codable. In other words, it seems that there is an area of the codable which is directly relevant to the actual coded message although it may not be actually included in the message. This area, for the purposes of this study, I shall call 'pre-semantic' to distinguish it from the area of the 'semantic' (the subject matter of Chapters I and III) and the area of the 'post-semantic' (the subject matter of Chapter II).

On the other hand, the pre-semantic area is to be distinguished from the Speaker's and Hearer's knowledge of reality - which is too wide for treatment, at least at the present stage of our knowledge.

Thus, the pre-semantic area is, as it were, midway between the area of the codable rather than the coded, what distinguishes it from the Speaker and the Hearer's total knowledge of reality is its immediate relevance to the coded message. The following diagram attempts to represent this distinction thus:

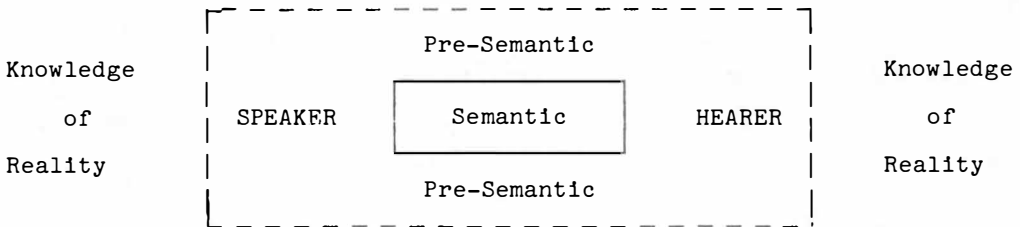

What will be said in this chapter concerning the pre-semantic area is, of course, exploratory in character. On the other hand, there are many important aspects and details of Pampangan grammar that do not lend themselves to satisfactory treatment without taking into account what I shall call 'pre-semantic structures'; hence, the topics in this chapter.

What I shall discuss under 'pre-semantic structures' constitutes the area of what the Oxford School of Linguistic Philosophy has called 'performatives' and 'illocutionary and perlocutionary verbs' (see Austin 1962 and Searle 1969 for an exposition of the theory and Ross 1968 for an attempt to deal with one type of performative in a transformational generative grammar framework) and of what some of the abstract syntacticists have called the area of 'presuppositions' (see Morgan 1969) and 'hypersentences and superhypersentences' (see Sadock 1969a, b).

This chapter will attempt to deal with similar phenomena insofar as such phenomena find analogues in Pampangan within the frame of reference adopted in this study. What will be essayed, therefore, is a way of treating such phenomena within the theory. That such phenomena have to be accounted for in a grammar is incontrovertible; unless they are treated, the two other important functions of language in addition to what Bühler (1934) calls *Darstellungsfunktion* (cognitive function), that of *Kundgabefunktion* (expression function), would not be accounted for. How such phenomena are treated depends, of course, on the orientation of the model being used.

In discussing the pre-semantic area, the method of explicit paraphrase will be used as a heuristic device. The device has been adopted merely as a convenience, with no psycho-linguistic validity claimed for the pre-semantic structures discussed; the claim, however, is that the information represented by these pre-semantic structures must be cognitively salient to the interlocutors and must be mentally processed in some way.

By treating pre-semantic structures, codable phenomena immediately relevant to the coded message, as if they were actually coded, rules of the same form as the semantic specification and replacement rules can be formulated. They will be distinguished from semantic rules (S ) and post-semantic rules (T ) by being marked (PS ). The usefulness of this heuristic device will be demonstrated as the discussion proceeds.

The first section of the chapter deals with social markers in speech which have linguistic reflexes; the next two sections discuss pre-semantic structures relevant to expressive and conative functions of language. The final section summarises the discussion and shows the relevance of pre-semantic structures to a small segment of discourse.

#### 4.1. SOCIAL MARKERS

##### 4.1.1. Respectful

Consider the sentence:

(4.1.1.1)\* Mañ Usí†## dñnatáñ na ya pu? # i Pédrú >  
 Mañ Usí†## dñnatáñ né pu? # i Pédrú  
 'Mr. Jose, Sir, Pedro has already arrived.'

(Mañ 'mister', dátañ 'arrive', na 'subitive: already', pu? 'respect marker'). The above sentence exemplifies the traditional vocative case as well as the use of the sociolinguistic marker pu? as an indicator of respect. Although pu? is loosely translated as 'Sir/Mister/Madam', it is not really a title but merely a respect marker attached to the verb. It is used in talking to someone who is superior in age or social rank or to someone who is an equal but with whom one is not on familiar terms (hence, it figures prominently in introductions). The latter use (among social equals) is disappearing in urban areas, where a less formal attitude is prevalent. The marker is carried all through a discourse every time a verb is used, even when one is not addressing the hearer directly but merely reporting to him about a third person, as in the example given. Although pu? cannot be considered a pronoun, in its explicit indication of respect toward the addressee, it is comparable to the 'ethical dative' of older German and of Modern Basque

(where gender distinction is further coded). However, since the ethical dative is usually employed in colloquial rather than formal discourse, the function of *pu?* in Pampangan shares features with the function of German *Sie* and Basque *suk*.

To treat of such sociolinguistic phenomena and to integrate them within a semantic theory, it seems that the message must be located within what I would call a pre-semantic configuration consisting of a pre-semantic verb of action which is further specified as verbal, completable, and directional (to), involving the Speaker as agent, the Hearer as goal, and the Message (a semantic configuration embedded in the pre-semantic configuration) as complement. The pre-semantic verb as well as its accompanying N's (when they are not coded) I shall label 'illocutionary' in its etymological meaning of '*not said, not expressed*'; merely as a notational convenience, I shall use an asterisk to indicate an illocutionary category: V\* and N\*. The following pre-semantic rule will be needed (in a more adequate formulation, several rules developing the configuration in various stages may be necessary):

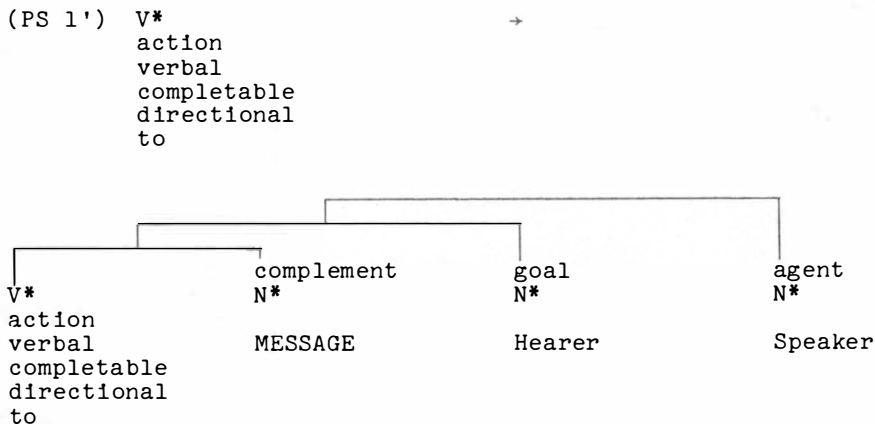

In the sentence given at the beginning of this section, the Hearer is explicitly coded; once thus coded, goal N\* enters the semantic area and must be represented as goal N. It is possible, of course, for the whole pre-semantic configuration to be explicitly coded, in which case it ceases to be a pre-semantic configuration but must be represented as a semantic one, as in:

(4.1.1.2) Maṅ Usít ## sasabiyán ku pú? #  
 kékayú ## dínatán né pu? # i Pédro  
 'Mr. Jose, Sir, [it] is being said by me  
 to you: Pedro has already arrived.'

(sabiyán 'to tell [somebody]', kékayú 'to you (plural)').





the Pampangan sentence interesting is its redundant marking: the literalisation whereby second person is expressed by a name; the marking of the name as associative plural; the incorporation of 'respectful' in V, symbolised as pu?.

#### 4.1.2. Familiar

Consider the following sentences:

- (4.1.2.1) Pedró† ## muntá ku # kéni # búkas  
'Pedro, I am coming here tomorrow.'
- (4.1.2.2) Máŋ Pedró† ## muntá ku pú? # kéni # búkas  
'Mr. Pedro, Sir, I am coming here tomorrow.'
- (4.1.2.3) Ábe† ## muntá katá # kéni # búkas  
'Friend, you and I are coming here tomorrow.' =  
'Friend, I am coming here tomorrow.'

The first sentence is unmarked for 'respectful' or 'familiar'. The second sentence is specified as 'respectful': máŋ is a title used for an elder male. The third sentence is specified as 'familiar': \*ábay is a title for 'friend'; literally, it means 'companion'. What makes the third sentence different from the first one is the further specification of 'first person' by 'second person', rendering the agent N 'inclusive'. Thus, 'familiar' triggers a post-semantic process adding 'second person' to the agent N matrix, a kind of 'conspiratorial we' definitely indicating to the Hearer that one considers him a friend. The relevant rules are:

(PS 4') V\* ->> familiar  
-respectful

In turn, there will be need of a semantic rule:

(S3 ) V  
root >> familiar / V\*  
familiar

Then, there will be need for a post-semantic rule:

(T ) N >> second person / familiar  
first person

#### 4.2. EXPRESSIVE FUNCTIONS

An illocutionary verb (V\*) specified as action, verbal, completable, directional (to), has been postulated as generating a pre-semantic structure in which is embedded a semantic structure. Such a V\*, besides being optionally specifiable as 'respectful' or 'familiar', may like-

wise be specified as either 'expressive' or 'conative', using these terms in their traditional sense, on the one hand, 'indicating the speaker's attitude towards a proposition', on the other hand, 'indicating the speaker's intention to induce some kind of response from the hearer'. When V\* is either expressive or conative, it generates a complement (N\*) in which is embedded another pre-semantic verb (to be noted as V\*\*) which in turn is accompanied by its own complement (N\*\*), a semantic configuration.

4.2.1. V\*\* : Apparentive, Informative, Questive, Super-prehensive  
state  
experiential

Consider the following sentences:

- (4.2.1.1)\* ma+lagú? ya áta? # iη dalága >  
malagú yáta? # iη dalága  
*'It seems to me that the young woman is pretty.'*
- (4.2.1.2) malagú ya palá # iη dalága  
*'I am now informed that the young woman is pretty.'* =  
*'So the young woman is pretty.'*
- (4.2.1.3) malagú ya kayá? # iη dalága  
*'I wonder if the young woman is pretty.'*
- (4.2.1.4) malagú ya # iη dalága†k  
*'It surprises me to be informed that the young woman is pretty.'*

(where † k is an ad hoc notation indicating not only marked breath-group but the appropriate kinesic gestures of surprise).

The sentences cited pre-suppose an experiencer (the Speaker) indicating his reaction to some stimulus (semantically, a V N configuration referring to some state or event). A pre-semantic verb V\*\*, embedded in the complement (N\*) of V\*, an experiential state V\*\* further specified as apparentive, informative, or questive, must then be posited. If specified as informative, it may be further specified as super-prehensive. The configuration may be represented thus:

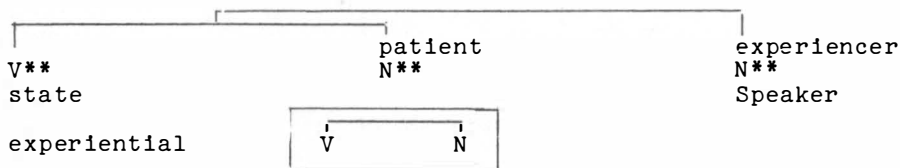

The following rules may be formulated:

(PS 5')	V*	→	
	action		
	verbal		
	expressive		
	completable		
			complement
	V*		N*
	action		
	verbal		
	expressive		
	completable		
			V**
(PS 6')	V**	- →→	state
(PS 7')	V**	- →→	experiential
	state		
(PS 8')	V**	→→	{apparentive informative questive}
	experiential		
(PS 9')	V**	- →→	super-prehensive
	informative		

The semantic rules would have to postulate that the above specifications are incorporated into semantic V and eventually linearised within V, except for 'super-prehensive', which is post-posed. The symbolisation of 'apparentive' is  $\acute{s}ta?$ , of 'informative' is  $pa\acute{a}$ , of 'questive' is  $ka\acute{y}a?$ , and of 'super-prehensive' is  $\acute{t}k$ .

#### 4.2.2. V\*\* action

V\*\*, instead of being specified as state, may be specified as action; action

action may then be further specified as either psychological or verbal. If specified as psychological, it may be either ratiocinative or velleitive. Under ratiocinative is inferential specification; under velleitive, purposive and optative.

##### 4.2.2.1. V\*\* : Ratiocinative and Velleitive action psychological

###### 4.2.2.1.1. Ratiocinative: Inferential

Consider the sentence:

(4.2.2.1.1.1)  $n\acute{u}n\ \acute{m}akaniy\acute{a}n\ \#\#\ \acute{d}\acute{f}nat\acute{o}n\ ya\ \#\ i\ \acute{P}\acute{e}dru$

'If such [is the case], [then I infer that] Pedro arrived.'

(nuḡ 'if', makan!yǎn 'such is the case' (a pro-sentence referring to a previous  $\overline{V \quad N}$  configuration), dátaḡ 'arrive'). The unit 'inferential' is incorporated into semantic V but is post-semantically deleted. Hence, it receives no symbolisation.

#### 4.2.2.1.2. Velleitive: Purposive and Optative

Consider the sentence:

(4.2.2.1.2.1) muntǎ ku sǎna # (kiḡ) Mǎnfla?  
'I purposed to go to Manila (but...).'

where the unit 'purposive' must be incorporated into semantic V and post-semantically linearised and symbolised by sǎna ~ sǎ?. It presupposes that the intention was never realised because of some state or event that prevented the accomplishment of the action.

Instead of aiming to do something, one may opt for a state or situation, in other words, wish for it, as in:

(4.2.2.1.2.2) doktór ku sǎna  
'I wish I were a doctor.'

where the unit 'optative' is symbolised by sǎna ~ sa?, homophonous with the symbolisation of 'purposive'. It is possible to wish for an event or situation contrary to fact (traditional subjunctive), as in:

(4.2.2.1.2.3) nuḡ doktór ku sǎna  
'If only I were a doctor (but I am not a doctor).'

where the unit 'subjunctive' or 'contrary to fact' is an inflectional specification of semantic V. 'Subjunctive' is post-semantically linearised by being preposed and symbolised by nuḡ 'if', while 'optative' is post-posed and symbolised by sǎna ~ sǎ?.

The relevant pre-semantic rules for section 4.2.2.1 are:

(PS 10')	V** -state	→→	action
(PS 11')	V** action	- →→	psychological
(PS 12')	V** psychological	→→	{ratiocinative velleitive}
(PS 13')	V** ratiocinative	→→	inferential
(PS 14')	V** velleitive	→→	{purposive optative}

4.2.2.2. V\*\* : Exclamative, Concurative, Demurrant  
 action  
 verbal

Instead of being specified as 'psychological', V\*\* may be specified as 'verbal'. A verbal V\*\* may be further specified as 'exclamative', 'concurative', and 'demurrant'.

Consider this sentence:

(4.2.2.2.1) kasantŋ na niŋ anák↑  
*'How pretty the child is!'*

where the pre-semantic unit 'exclamative' has been incorporated into the state V masantŋ 'pretty'. Post-semantically, the unit 'exclamative' blocks subjectivisation. In symbolisation, it calls for a marked breath-group (↑) and shifts m to k: masantŋ > kasantŋ. Peculiar properties of particular lexical items would have to be stated in symbolisation rules; for example, 'exclamative' is sometimes symbolised by ka-...-an and:

(4.2.2.2.2) kayanakán na niŋ babáye↑  
*'How young the woman is!'*

The rising intonation is the phonological context for the i to e shift: babáyi > babáye. Besides blocking subjectivisation, 'exclamative' occurs only with state V's.

Instead of 'exclamative', V\*\* may be specified as 'concurative':

(4.2.2.2.3)\* ma+santŋ ya pin # iŋ anák >  
 masantiŋ yá pin # iŋ anák  
*'I concur: The child is pretty.'*

where pin symbolises agreement or concurrence with a previous statement.

On the other hand, instead of concurring, one may demur (in Pampangan, this demur is a mild one; another V root would be necessary for explicit disagreement):

(4.2.2.2.4)\* ma+santŋ na ya man # iŋ anák >  
 masantŋ né man # iŋ anák  
*'I beg to differ: The child IS pretty.'*

The symbolisation for 'demurrant' is na...man (na is not to be confused with the copier na nor with 'subitive' na nor with the semantically vacuous na used in V's specified as perseverative) and is linearised by having the subject copier interposed between its discontinuous morphs. If there are two copiers, both copiers are interposed between na and man:

- (4.2.2.2.5)\* b+intiyáy na na ya man niñ anák # iñ librú >  
 biniyé na né man niñ anák # iñ librú  
 'I beg to differ: The book WAS given by the child.'

It is interesting to note that 'exclamative' and 'concurative' may occur together:

- (4.2.2.2.6)\* ka+santíñ na pin niñ anák† >  
 kasantíñ ná pin niñ anák†  
 'I concur: How pretty the child is!'

pre-supposing that someone else has previously remarked, 'How pretty the child is!' Moreover, 'concurative' may not occur with 'demurrant' with regard to the same statement, but one may concur with somebody else's demur:

- (4.2.2.2.7)\* ma+santíñ na ya man pin # iñ anák >  
 masantíñ né man pín # iñ anák  
 'I concur with X's demur: The child IS pretty!'

Again, it is possible for 'demurrant' and 'exclamative' to occur together:

- (4.2.2.2.8) kasantíñ na na mán niñ anák†  
 'I beg to differ: How pretty the child is!'

The preceding sentence pre-supposes that a comment such as 'The child is ugly' has been made; one disagrees with the comment and on the contrary adds a new comment to the effect that not only is the child not ugly but also that the child is actually pretty. Finally, it is possible to have all three specifications together:

- (4.2.2.2.9) kasantíñ na na mán pín niñ anák†  
 'I concur [with someone's demur and contrary comment]:  
 On the contrary, how pretty the child is!'

The specifications described play a very important role in discourse, since they link an utterance with previous utterances in the discourse, utterances which may be several sentences removed from a present one being said. The following pre-semantic rules may be formulated:

- (PS 15') v\*\* - → verbal  
 action  
 -psychological
- (PS 16') v\*\* → (exclamative)  
 verbal (concurative)  
 demurrant

## 4.3. CONATIVE FUNCTIONS

4.3.1. V\*\* : Imperative and Precative  
action  
verbal  
conative

An action V\*, instead of being specified as expressive, may be specified as conative, insofar as the Speaker seeks to induce a response on the part of the Hearer. The specification 'conative' denotes commands of all kinds, including commands to answer questions. In turn, 'conative' may be further specified as 'precative' or 'requestive' and hence, a request would be considered more marked than a command.

## 4.3.1.1. Commands

Consider the sentence:

- (4.3.1.1.1) muntá ka # kění  
'Come here.'  
'You will come here.'

As the glosses indicate, the sentence is ambiguous. In both instances, V is aspectually -actual. There is thus no overt linguistic marking for 'conative'. If V is negative, an interesting aspectual shift obtains:

- (4.3.1.1.1a) é ka púpuntá # kění  
'Do not come here.'  
'You are not coming here.'

There is thus need to posit a post-semantic rule:

(T )	V	→	V
	-state		-state
	root		root / V*
	-actual		actual conative
	negative		durative
			negative

Of course, a prior semantic rule for commands would need to be posited:

(S 4)	V	→→	-actual / V*
	root		conative

## 4.3.1.2. Requests

V\* may be further specified as 'precative':  
conative

- (4.3.1.2.1) muntá na ka mó # kéné†  
'Kindly come here.'

where 'precative', incorporated as an inflectional unit into V, is linearised in V and symbolised by the discontinuous morphs *na...mo* and a marked breath-group terminal marker ( † ). A negative request likewise triggers an aspectual shift:

- (4.3.1.2.1a) *é na ka mó púpuntá # kéne†*  
*'Kindly do not come here.'*

Another way of expressing a request is to literalise it as a wish:

- (4.3.1.2.2) *muntá ka sána # kéni*  
*'I wish you would come here.' = 'Kindly come here.'*

With the use of idioms such as the above, perhaps 'precative' can be specified further for various degrees of precatation. With certain verb roots, there is a redundant precatative marker *paki-*:

- (4.3.1.2.3)\* *paki+súlat mu na ya mo # in† >*  
*pakisúlat mu né mo # iné†*  
*'This will be included among those things you are writing, kindly.' = 'Please write this.'*

It should be noted in the above sentence that the discontinuous precatative morph does not enclose the copiers but is interposed between the two copiers:

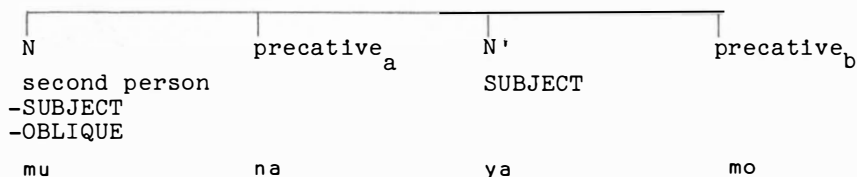

Without precatative specification, one would have:

- (4.3.1.2.3a) *pakisúlat me # in†*  
*'This is to be included by you among those items which you are writing.'*

where the subject is an associate N (-animate) and the verb root has the derivational unit associativiser (\* *maki-* > *paki-* because of the associate subject). It is possible to express (4.3.1.2.3') without *paki-*:

- (4.3.1.2.3') *isúlat mu né mo # iné†*  
*'Kindly write this.'*

The addition of *paki-* seems to strengthen the notion of precatation: one is requesting the hearer to do something but only because he is doing other similar things to which this task can be added. It seems that *paki-* is best treated as the literalisation of 'precatative' speci-

fied further as *'not wishing to impose'*. The following pre-semantic rules may be formulated:

(PS 17') V\*                    - →    conative  
           action  
           -expressive

(PS 18') V\*                    - →    precative  
           conative

'Precative' is incorporated into semantic V and is linearised and symbolised by na...mo and †.

#### 4.3.2. V\*\*           action

In the preceding section, on conative verbal action V\*, it was proposed that in every command or request, a V\* must be postulated in pre-semantic structure, a V\* which is accompanied by an agent N\*, the Speaker, a goal N\*, the Hearer, and a complement N\*, under which is embedded the message, with its semantic structure, what is to be done. Now, where V\* is conative, the embedded semantic V is an action, a task to be performed, and the agent N is always 'second person' which is of course co-referential with the Hearer. The configuration may be represented thus:

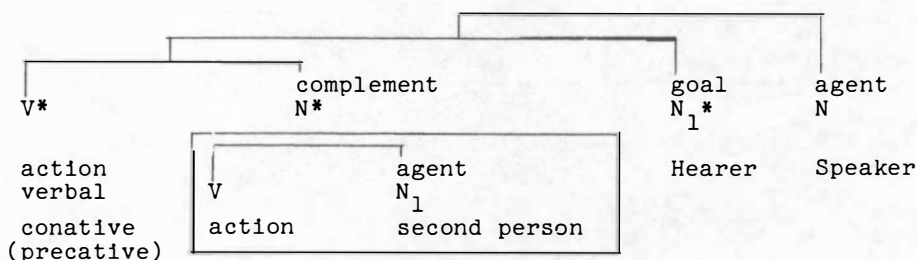

It is possible, however, for the verb embedded in complement N\* to be likewise an illocutionary V instead of a semantic V. Such an embedded illocutionary V will be noted as V\*\*; like any illocutionary verb, V\*\* must be accompanied by a complement N\*\* which in turn may dominate an embedded semantic V. The following example will clarify this:

(4.3.2.1) lótsen ## dátaŋ ya # i Pédru  
           '*Believe me, Pedro is coming.*'

where lótsen is a formative (of unknown etymology at present) loosely translatable as *'believe me'*; the unit may therefore be labelled 'fiduciative'. The above sentence is an instance of the following situation: The Speaker is asking (V\* is therefore conative) the Hearer to do something (complement N\*) and this something, as with other

conative V\*'s, is an action, an action which is psychological, the action of believing. In turn, the embedded verb implies an agent (the Hearer) and a beneficiary (the Speaker) as well as a complement, the message itself, that Pedro is coming. Now it seems that the fiduciative verb is an illocutionary verb, hence V\*\* - the only indicator is an unanalysable formative which actually stands for the whole V\*\* configuration (with its accompanying N\*\*'s) except for the message itself, which is coded. The configuration may be represented thus:

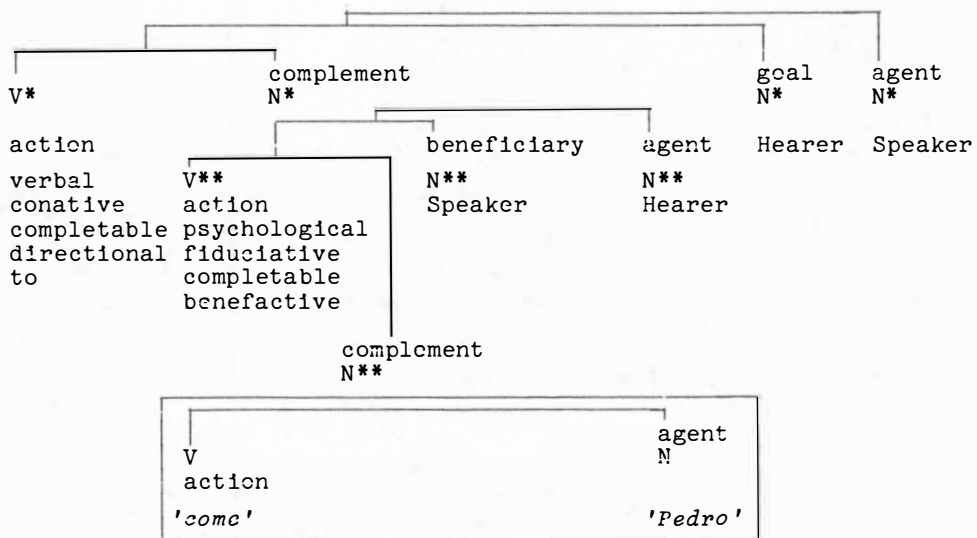

4.3.2.1. V\*\* : Fiduciative, Pretensive, Suppositive  
 action  
 psychological

Consider the following sentences:

(4.3.2.1.1) lótsen ## malagú ya # in dalága ~  
 malagú ya # in dalága ## lótsen  
 'Believe me, the young woman is pretty.'

(4.3.2.1.2) nuṅ wári? ## malagú ya # in dalága ~  
 malagú ya # in dalága ## nuṅ wári?  
 'Let us pretend that the young woman is pretty.'

(4.3.2.1.3) malagú ya mó # in dalága  
 'Let us suppose that the young woman is pretty.'

It seems best to treat lótsen ~ lótsin as a direct symbolisation of V\*\* while nuṅ wári? (nuṅ is likewise used to symbolise 'if')  
 action  
 psychological  
 fiduciative

is a direct symbolisation of V\*\* . In the case of 'supposi-  
 action  
 psychological  
 pretensive  
 tive', it seems that V\*\* is not symbolised directly but that the unit  
 'suppositive' is incorporated into semantic V and is eventually  
 linearised and symbolised as mo, a particle within the verb phrase.  
 The following pre-semantic rules may be formulated:

- (PS 19')    V\*                    - →  
 action  
 verbal  
 conative  
 completable
- |    |        |        |          |             |
|----|--------|--------|----------|-------------|
| V* | action | verbal | conative | completable |
|    |        |        |          |             |
|    |        |        |          |             |
|    |        |        |          |             |
|    |        |        |          |             |
|    |        |        |          |             |
|    |        |        |          |             |
|    |        |        |          |             |
|    |        |        |          |             |
|    |        |        |          |             |
|    |        |        |          |             |
|    |        |        |          |             |
|    |        |        |          |             |
|    |        |        |          |             |
|    |        |        |          |             |
|    |        |        |          |             |
|    |        |        |          |             |
|    |        |        |          |             |
|    |        |        |          |             |
|    |        |        |          |             |
|    |        |        |          |             |
|    |        |        |          |             |
|    |        |        |          |             |
|    |        |        |          |             |
|    |        |        |          |             |
|    |        |        |          |             |
|    |        |        |          |             |
|    |        |        |          |             |
|    |        |        |          |             |
|    |        |        |          |             |
|    |        |        |          |             |
|    |        |        |          |             |
|    |        |        |          |             |
|    |        |        |          |             |
|    |        |        |          |             |
|    |        |        |          |             |
|    |        |        |          |             |
|    |        |        |          |             |
|    |        |        |          |             |
|    |        |        |          |             |
|    |        |        |          |             |
|    |        |        |          |             |
|    |        |        |          |             |
|    |        |        |          |             |
|    |        |        |          |             |
|    |        |        |          |             |
|    |        |        |          |             |
|    |        |        |          |             |
|    |        |        |          |             |
|    |        |        |          |             |
|    |        |        |          |             |
|    |        |        |          |             |
|    |        |        |          |             |
|    |        |        |          |             |
|    |        |        |          |             |
|    |        |        |          |             |
|    |        |        |          |             |
|    |        |        |          |             |
|    |        |        |          |             |
|    |        |        |          |             |
|    |        |        |          |             |
|    |        |        |          |             |
|    |        |        |          |             |
|    |        |        |          |             |
|    |        |        |          |             |
|    |        |        |          |             |
|    |        |        |          |             |
|    |        |        |          |             |
|    |        |        |          |             |
|    |        |        |          |             |
|    |        |        |          |             |
|    |        |        |          |             |
|    |        |        |          |             |
|    |        |        |          |             |
|    |        |        |          |             |
|    |        |        |          |             |
|    |        |        |          |             |
|    |        |        |          |             |
|    |        |        |          |             |
|    |        |        |          |             |
|    |        |        |          |             |
|    |        |        |          |             |
|    |        |        |          |             |
|    |        |        |          |             |
|    |        |        |          |             |
|    |        |        |          |             |
|    |        |        |          |             |
|    |        |        |          |             |
|    |        |        |          |             |
|    |        |        |          |             |
|    |        |        |          |             |
|    |        |        |          |             |
|    |        |        |          |             |
|    |        |        |          |             |
|    |        |        |          |             |
|    |        |        |          |             |
|    |        |        |          |             |
|    |        |        |          |             |
|    |        |        |          |             |
|    |        |        |          |             |
|    |        |        |          |             |
|    |        |        |          |             |
|    |        |        |          |             |
|    |        |        |          |             |
|    |        |        |          |             |
|    |        |        |          |             |
|    |        |        |          |             |
|    |        |        |          |             |

(A) V	(B) V
process	process
action	action
(no root)	'cut'
actual	actual
durative	durative
agent subject	agent subject

In other words, the response merely lexically specifies the root that was missing in the query. The pre-semantic structure of the query is more complicated, however, as the configurations following show. Semantically, 'interrogative', a specification of V\*\*, is paraphrasable as *'You tell me by filling in the blank'*; the unit is eventually incorporated into semantic V, which thus becomes V with its **interrogative** other specifications and is eventually symbolised by *nánánu*. As the second configuration which follows shows, the response is much simpler since the semantic structure  $\overline{V \quad N}$  is directly dominated by complement N\* without an intervening V\*\*. (See overleaf.)

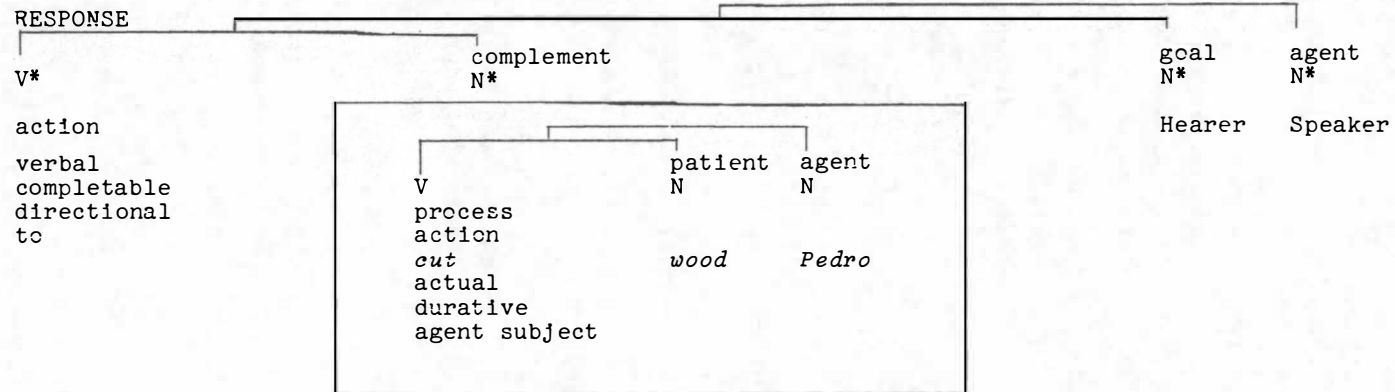
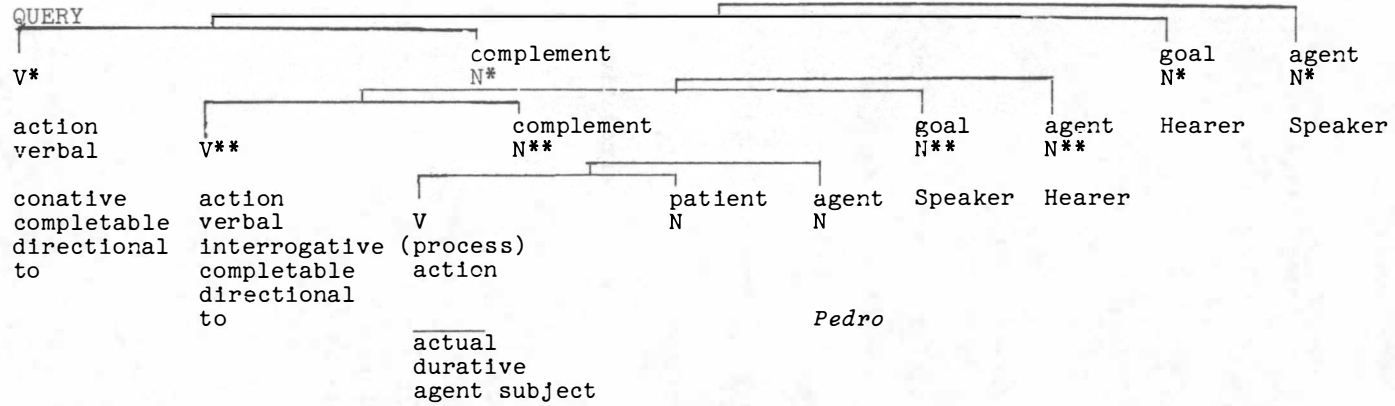

It is perhaps redundant to remark that in the response, V in the instance given is new whereas the subject is -new and hence is usually deleted, unless there is a special reason for not deleting it (for example, emphasis).

The symbolisation of the different types of V interrogative may be exemplified thus:

(4.3.2.2.1.2) mananánu ya # i Pédro  
 mamamaté ya (# i Pédro)  
 x 'Pedro is being whatted.' =  
 'What is happening to Pedro?' 'He is dying.'

(4.3.2.2.1.3) makanánu ya # i Pédro  
 másakít ya (# i Pédro)  
 x 'Pedro is like what' = 'How is Pedro?'  
 'He is sick.'

It is possible for V interrogative to be specified for a lexical derivational unit; it seems that only the root need be missing:

(4.3.2.2.1.4) mákanánu ya # i Pédro  
 mákalákad ya (# i Pédro)  
 'Pedro is able to do what.' = 'What is Pedro able  
 to do?' 'He can walk.'

where abilitativiser<sub>1</sub> is symbolised by máka-; the verb in the question is therefore V interrogative. Again, V interrogative may be specified for other aspects, as in:

(4.3.2.2.1.5) nínánu ya # i Pédro  
 mínútut yaḡ dútuḡ (# i Pédro)  
 x 'Pedro whatted.' = 'What did Pedro do?'  
 'He cut wood.'

(4.3.2.2.1.6) numánu ya # i Pédro  
 pumútut yaḡ dútuḡ (# i Pédro)  
 x 'Pedro will what?' = 'What will Pedro do?'  
 'He will cut wood.'

(4.3.2.2.1.7) kanánunánu na pá muḡ Pédro  
 kapútutpútut na pá muḡ dútuḡ (Pédro)  
 x 'Pedro has just now whatted.' = 'What has Pedro  
 just now down?' 'He has just now cut wood.'

It is possible for V interrogative, like any V, to be specified post-semantically for a subject other than agent or patient. Only two examples will be cited to illustrate:

- (4.2.3.3.1.8) nanánan neḡ Pédrú # iḡ dútuḡ  
 puputútan neḡ Pédrú (# iḡ dútuḡ)  
 x 'The wood is being whatted by Pedro.' =  
 'What is Pedro doing to the wood?'  
 'It is being cut by Pedro.'
- (4.2.3.3.1.9)\* ipaḡ+nánu na ya naḡ Pédrú # iḡ tabák >  
 paḡnánu neḡ Pédrú # iḡ tabák  
 \* ipaḡ+pútut na ya naḡ Pédrú # iḡ tabák >  
 pám útut neḡ Pédrú (# iḡ tabák)  
 x 'The knife is being whatted with by Pedro.' =  
 'What is Pedro doing with the knife?'  
 'It is being used to cut with by Pedro.'

4.3.2.2.2. V  
 numerical  
 interrogative

A state may be further specified as quantitative and numerical and instead of being lexically specified, incorporate 'interrogative' from V\*\*  
 ;  
 interrogative

- (4.3.2.2.2.1) pilán la # diḡ ának  
 aduá la (# diḡ ának)  
 'The children are how many?' =  
 'How many children are there?'  
 'They are two [in number].'

A numerical quantitative state V may be further specified as ordinal:

- (4.3.2.2.2.2) ikapilán ya # iḡ anák  
 ikaduá ya (# iḡ anák)  
 x 'The child is what rank?' =  
 'What is the rank of the child?'  
 'He is the second [in rank].'

Instead of ordinal, V may be specified as grouped:

- (4.3.2.2.2.3)<sup>x</sup> tlyápilánplán la # diḡ ának  
 makanánu la # diḡ ának  
 tiduátiduá la (# diḡ ának)  
 'How are the children?' =  
 'How many children are in each group?'  
 'They are in groups of two.'

The question for a state V specified as numerical and grouped is irregular; following the pattern earlier established, one would expect

<sup>x</sup>tiyápilánpilán lit. 'in groups of how many+how many'; however, makanánu is used, the same formative for 'how'.

Instead of ordinal or grouped, a numerical quantitative state V may be specified as instantive:

- (4.3.2.2.2.4) makatapilán # in pámaglútu?  
 makataduá (# in pámaglútu?)  
<sup>x</sup>'The cooking is how many times?'  
 'How many times does one cook?'  
 'It is done twice.'

Problematic are questions such as 'How much?' and 'How much each?' Consider the sentence:

- (4.3.2.2.2.5) aduá yan pésus # in libru  
 'The book [costs] two pesos.'

which may be analysed as:

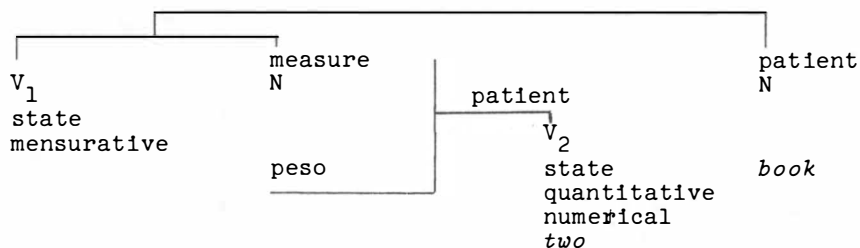

The verbal nature of numbers in Pampangan has already been discussed in Chapter I. Now, if  $V_2$  is interrogative, one has:

- (4.3.2.2.2.5a) pilán yan pésus # in libru  
 'The book [costs] how many pesos?'

where pilán symbolises  $V_2$  state quantitative. On the other hand, one can like-

wise ask:

- (4.3.2.2.2.6) magkánu ya # in libru  
 aduá yan pésus (# in libru)  
 'How much [does] the book cost?'  
 'It [costs] two pesos.'

It seems that magkánu is a symbolisation of the configuration

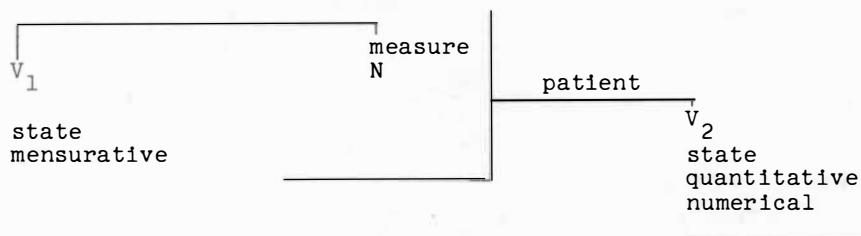

into which 'interrogative' has been incorporated from V\*\*  
interrogative

How to formalise this remains a problem.

librú 'book' may be inflectionally specified as plural and individuated, as in:

- (4.3.2.2.2.7) tiyápilán laŋ pésus # diŋ librú  
 tiyátiduá laŋ pésus (# diŋ librú)  
 'The books [cost] how many pesos each?'  
 'They [cost] two pesos each.'

where tiyátiduá? < \*tiyá+ti+aduá? (with syllabic epenthesis) <  
 \*tiyá?+aduá? is a symbolisation of V<sub>2</sub>, with the unit 'individuated'  
 two  
 individuated

ated' incorporated into the verb from the patient N, librú, and symbolised as an affix. The same incorporation seems to occur in a related question:

- (4.3.2.2.2.7a) tiyámagkánu la # diŋ librú  
 'The books [cost] how much each?'

where tiyámagkánu is a direct symbolisation of the configuration described for magkánu with the incorporated unit 'individuated'.

In symbolisation quite similar to (4.3.2.2.2.7) but semantically distinct is:

- (4.3.2.2.2.8) tiyápilán laŋ dalandán # diŋ ának  
 tiyátiduá laŋ dalandán (# diŋ ának)  
 'The children [are to be given] how many oranges each?'  
 'They [are to be given] two oranges each.'

The semantic structure of the sentence may be represented as:

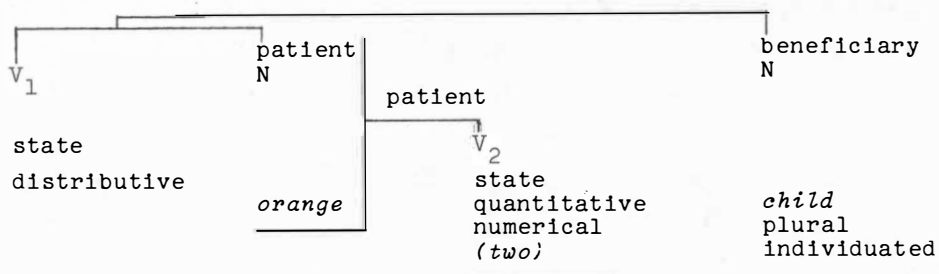

where again  $tiyáplíán$  symbolises  $V_2$ . Hence, the formative  
state  
quantitative  
numerical  
interrogative  
individuated

is analysable in exactly the same way in both sentences (4.3.2.2.7 and 4.3.2.2.8); what makes the two sentences distinct is the entirely different specification of  $V_1$  (mensurative and distributive) and the resulting difference in configuration.

#### 4.3.2.2.3. Classificatory Verbs

There are two classificatory verbs in Pampangan which are used in questions: *maliyári* lit. 'to happen', which is used for process V's or for any -state V and *gáwa?* lit. 'to make', which is used for action and process-action V's. One may ask:

- (4.3.2.2.3.1) *mananánu ya # | Pédro*  
*x 'Pedro is being whatted.' =*  
*'What is happening to Pedro?'*

Or alternatively one may ask:

- (4.3.2.2.3.2) *nánu # iŋ maliliyári kaŋ Pédro*  
*'The [event which] is happening to Pedro is what?'*

The configuration of the second sentence is altogether different:

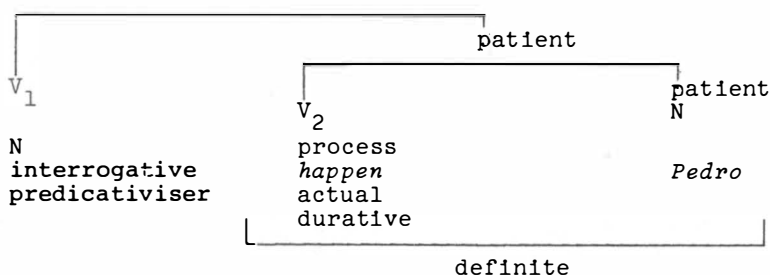

The embedded  $V_2$  N configuration is in a patient relation to  $V_1$ , which is completely unspecified. However, the fact that  $V_2$  is specified as a process indicates that the response must begin with a process V. The answer to the query may take two forms:

- (4.3.2.2.2.2a) *mamamaté # iŋ maliliyári kaŋ Pédro*  
*'The [event which] is happening to Pedro is dying.'*
- (4.3.2.2.3.2b) *mamamaté ya (# i Pédro)*  
*'He is dying.'*

maliyári classifies the response as a process. In answering the question, therefore, the language performer must begin with a process V (adding the accompanying N by applying the semantic rules). One then has a configuration:

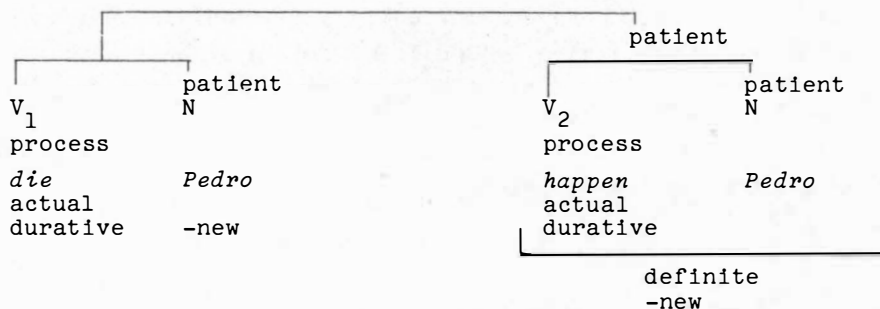

Hence, a truly equational sentence is generated. It seems that a choice is allowed to be applied in the deletion processes. One may either delete the whole  $\overbrace{V_2 \quad N}$  sub-configuration which is -new anyway, or one may retain this sub-configuration and delete the -new matrix (patient N) to the left, but not both, since a process V, unless it is ambient, must have at least one accompanying N (or at least, a copier).

The same types of processes apply to classificatory action and process-action V gawa?, which needs only exemplification. One may ask:

- (4.3.2.2.3.3) nánánu ya # i Pédrú  
 x 'Pedro is whatting.' =  
 'What is Pedro doing?'

Or one may ask:

- (4.3.2.2.3.4) nánu # in gagáwan naḡ Pédrú  
 'The [action which] is being made by Pedro is what.' =  
 'What is Pedro doing?'

To which the responses would be:

- (4.3.2.2.3.5a) púpútut dútuḡ # in gagáwan naḡ Pédrú  
 'The [action which] is being made by Pedro  
 is cutting wood.'  
 (4.3.2.2.3.5b) púpútut yaḡ dútuḡ (# i Pédrú)  
 'He is cutting wood.'

Note that in structures such as (4.3.2.2.3.5a) and (4.3.2.2.3.2a), there are no copiers in the sub-configuration to the left. This may easily be accounted for by positing the deletion of the -new agent or patient N before the incorporation rules apply.

4.3.3.2.4. N  
interrogative

In preceding sections, questions generated by non-lexically specified V's incorporating 'interrogative' from V\*\*  
interrogative have been described.

It is possible, however, to have V lexically specified and instead to have one or more N's non-lexically specified and incorporating 'interrogative'. Such N  
interrogative matrices when symbolised give rise to

different types of WH-formatives, to use the label current in the transformational generative grammar literature.

4.3.3.2.4.1. N  
interrogative  
OBLIQUE

Consider the sentences:

(4.3.3.2.4.1.1)\* kaŋ nfnu ya miniyé péra # iŋ táu >  
ka nfnu ya miniyé péra # iŋ táu  
kaŋ Pédrú ya miniyé péra (# iŋ táu)  
'It is to whom that the man gave money.'  
'It is to Pedro that he gave money.'

where the matrix N	beneficiary	in the query is replaced by N	beneficiary
	human		human
	interrogative		Pedro
	definite		definite
	OBLIQUE		OBLIQUE

in the response. Since kanfnu is likewise used for -unique noun roots, the selectional unit 'unique' does not seem to be criterial for the eventual symbolisation of the matrix. However, the selectional unit 'human' is relevant, since there is a formative nánu 'what', which is used for -human N's. It seems that an oblique interrogative N must be additionally specified as TOPIC to explain the pre-posing of the N and the inter-posing of the copier between the interrogative and the V.

Like any N, oblique-marked interrogative N may be inflectionally specified as plural:

(4.3.3.2.4.1.1a)\* kaŋ nfnunfnu ya miniyé péra # iŋ táu >  
ka nfnunfnu ya miniyé péra # iŋ tau  
kari Pédrú ya miniyé péra (# iŋ táu)  
'It is to whom (plural) that the man gave money?'  
'It is to Pedro and his companions that he gave money.'

Other types of N<sup>rel</sup> which are interrogative and which are OBLIQUE give rise to other query words:

(4.3.3.2.4.1.2) kapilán ya makó # i Pédrú  
 keŋ lúnis ya makó (# i Pédrú)  
 'It is when that Pedro will leave?'  
 'It is on Monday that he will leave.'

(4.3.3.2.4.1.3) núkarín ya muntá # i Pédrú  
 kiŋ balé ya muntá (# i Pédrú)  
 'It is to where that Pedro will go?'  
 'It is to the house that he will go.'

Location N's, source N's, and goal N's, which are post-semantically OBLIQUE, when interrogative, are symbolised by \*nú+ka+dín > núkarín karín, it will be recalled, is likewise the symbolisation for the distal demonstrative.

Motive N's, which are usually marked OBLIQUE, demand a somewhat different treatment:

(4.3.3.2.4.1.4) óbákit méte ya # iŋ manúk  
 úli na niŋ pistí (## méte ya # iŋ manúk)  
 'Why is it that the chicken died?'  
 '(The chicken died) because of the pestilence.'

It seems that óbákit is a symbolisation for a whole  $\overline{V \quad N}$  configuration which is interrogative:

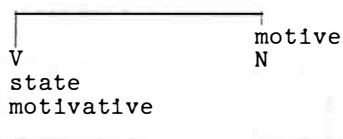

One may, however, likewise ask:

(4.3.3.2.4.1.5) úli na niŋ nánu ## méte ya # iŋ manúk  
 úli na niŋ pistí (## méte ya # iŋ manúk)  
 'It is because of what that the chicken died?'  
 '(The chicken died) because of the pestilence.'

Instances such as niŋ nánu 'of what', which is -OBLIQUE, will be discussed in the next section.

4.3.2.2.4.2. N  
interrogative  
-OBLIQUE

Consider the sentence:

(4.3.2.2.3.2.1) *babiyé yan digálu # kiŋ anák # iŋ táu*  
*'The man is giving [a] gift to the child.'*

where the semantic structure is:

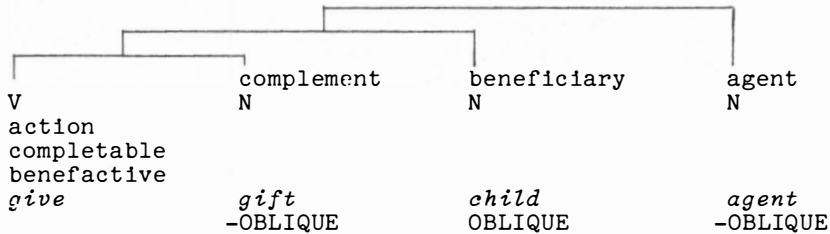

If the configuration is embedded in a V\*\* pre-semantic interrogative structure, with one or more of the N's not lexically specified, various types of WH-questions may be derived. In the preceding section, oblique-marked N's which were 'interrogative' were seen as topicalised and then pre-posed. The process was quite straightforward and uncomplicated. In the sentence cited, however, if one were to ask a question about the other N's (the subject N, an agent, or the -OBLIQUE and -SUBJECT N, a complement), the configuration of the question seems to be altogether different from the configuration of the declarative sentence cited:

(4.3.2.2.4.2.2) *nánu # iŋ báge a babiyé na niŋ táu # kiŋ anák digalu (# iŋ (báge a) babiyé na niŋ táu # kiŋ anák)*  
*'The (object which) is being given by the man to the child is what?' =*  
*'What is the man giving to the child?'*  
*'(The (object which) is being given by the man to the child is) a gift.'*

The subject N, with an attached relative clause, has for its noun root a classificatory noun \*bágay lit. 'thing'; it is usually deleted. The semantic structure may be represented thus:

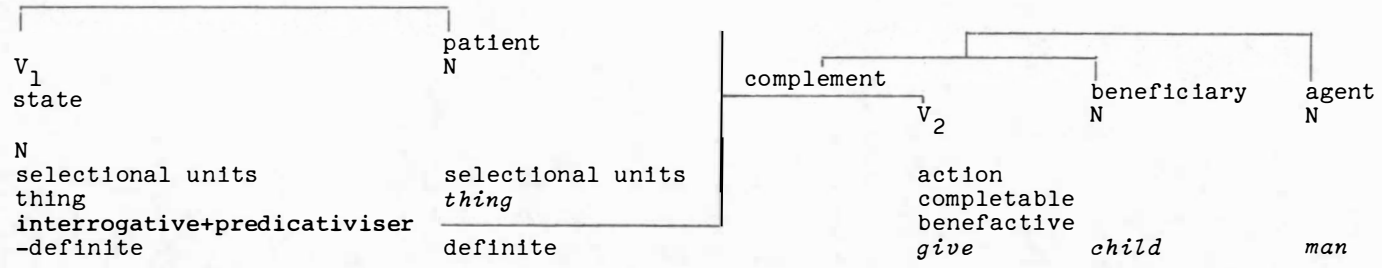

In effect, what obtains is a patient configuration which consists of a classificatory noun root \*bágay 'thing' to which is attached a restrictive relative clause which identifies which thing (the thing given to the child by the man); of this patient N is predicated a state V ( $V_1$ ), which is a predicate noun; the latter, however, is not lexically specified but is interrogative. In the response, interrogative is replaced by a noun root, 'gift', which specifies the classificatory noun 'thing' further into a particular kind of thing, a gift. Note that  $V_2$  has no subject or incorporated copier for the subject, although it agrees with bágé, which would have been its subject if it were an independent sentence.

Instead of asking about the complement N, one may ask about the agent N:

- (4.3.2.2.4.2.3)\* i nfnu # in táuη babiyé digálu # kiη anák >  
 nfnu # in táuη babiyé digálu # kiη anák  
 'The (person who) is giving a gift to the child  
 is who?' = 'Who is giving a gift to the child?'  
 i Pédrú (# in táuη babiyé digálu # kiη anák)  
 '(The person who is giving a gift to the child is)  
 Pedro.'

The same type of configuration described in connection with nánu applies to nfnu, except that nfnu is definite and is subjectivised. The determiner is deleted, however; the classificatory noun táu 'man, person' is likewise deletable.

It is possible for a predicate noun such as nfnu and nánu to be predicated of ordinary patient N's instead of  $\underline{N} \left[ \begin{array}{c} \text{V} \\ \text{N} \end{array} \right]$  configurations in a patient relation to the predicate noun. Such structures give rise to 'equational sentences':

- (4.3.2.2.4.2.4) nánu ya # i Pédrú  
 doktor ya (# i Pédrú)  
 'Pedro is a what?'  
 'He is a doctor.'
- (4.3.2.2.4.2.5)\* i nfnu # in doktór >  
 i Pédrú (# in doktór nfnu # in doktór)  
 'The doctor is who?'  
 'He is Pedro.'

In the preceding sentence, the subject does not undergo incorporation of some of its specifications into the state V, a definite predicate noun.

Non-oblique interrogative N's may be specified inflectionally as plural:

- (4.3.2.2.4.2.6) nfnunfnu # diŋ dfnatán  
'The [people who] arrived are who (plural)?'

Besides nánu 'what' and nfnu 'who', there is also sánu, the symbolisation for N  
(human)  
interrogative  
definite  
partitive

- (4.3.2.2.4.2.7) iŋ sánu kariŋ ának # iŋ mflayf?  
'The [one who] ran is which of the children.' =  
'Which one of the children ran?'

- (4.3.2.2.4.2.8) iŋ sánu kariŋ dalandán # iŋ péŋan na niŋ anák  
'The [one which] was eaten by the child  
is which of the oranges.' =  
'Which one of the oranges was eaten by the child?'

What makes analysis sometimes difficult for occurrences of nánu and nfnu is that there is a phonological rule which optionally deletes # and which brings about a phonological context for possible syncope:

- (4.3.2.2.4.2.9) nfnu # iŋ gágawán lamésa ~  
nfnu + ŋ gágawán lamésa  
'The [person by whom] a table is being made  
is who?' = 'Who is making a table?'

- (4.3.2.2.4.2.10) nánu # iŋ gagáwan na niŋ anák ~  
nánu + ŋ gagáwan na niŋ anák

The last sentence is ambiguous, for it means both:

'The [object which] is being made by the child  
is what.' = 'What is the child making?'

'The [action which] is being done by the child  
is what.' = 'What is the child doing?'

It should be emphasised that question words such as nfnu 'Who (unique or -unique)?', nánu 'What?', and sánu 'Which?' are basically N's without lexical specification. In other types of questions which will be discussed, these formatives are treated like ordinary N's; they may be OBLIQUE (\*kaŋ/kiŋ nfnu > kanfnu; kiŋ nánu; kiŋ sánu), SUBJECT (\*i/iŋ nfnu > nfnu; iŋ nánu; iŋ sánu), -SUBJECT and -OBLIQUE (\*naŋ/niŋ nfnu > nfnu; niŋ nánu; niŋ sánu). When nfnu is SUBJECT, the determiner is deleted.

What makes the types of questions discussed in this section different from the types of questions discussed in the immediately preceding section is their totally different semantic structure. Questions which ask about beneficiary N's, location N's, source N's, goal N's (which are all post-semantically OBLIQUE) have exactly the same configuration as ordinary sentences without interrogatives except that the OBLIQUE N is topicalised and pre-posed. Other types of questions, however, which have to do with N's which are -OBLIQUE post-semantically demand a configuration in which the question word is a predicate noun. Instead of asking

(4.3.2.2.4.2.11) iŋ sánu # iŋ géwa neŋ Pédro  
*'The [object which] was made by Pedro  
 is which [one]?' = 'Which one did Pedro make?'*

one may ask:

(4.3.2.2.4.2.11a) géwa neŋ Pédro # iŋ sánu  
*'The which was made by Pedro?'*

where the structure of the sentence is exactly the same as that of its non-interrogative counterpart except that the subject N is without lexical specification. However, the above sentence is not commonly used (in echo questions which will be discussed subsequently, it is used). The usual form of questions translatable by 'Who?', 'Which?', 'What?', is that of (4.3.2.2.4.2.11) and not of (4.3.2.2.4.2.11a).

It is difficult to make a case for considering the latter sentence as a 'transform' of the former sentence, since the structures are basically different; it would seem then that in the semantic generation of questions such as 'Who?', 'Which?' and 'What?' (as opposed to questions such as 'To whom?', 'For whom?', 'When?', 'Where?'), one begins with a totally different semantic configuration, a configuration different from its declarative correlative; the configuration of the response to the query is, of course, congruent with the configuration of the query. Thus:

(4.3.2.2.4.2.12) DECLARATIVE  
 lálákad ya # i Pédro  
*'Pedro is walking.'*  
 INTERROGATIVE  
 nínu # iŋ lálákad  
 i Pédro (# iŋ lálákad)  
*'The [person who] is walking is who?'*  
*'[It is] Pedro.'*

## 4.3.2.2.4.3. Classificatory Nouns in Questions

An N which is not lexically specified but instead incorporates 'interrogative' in lieu of a root may optionally be specified selectionally by a classificatory noun:

- (4.3.2.2.4.3.1) .kiŋ sánuŋ anák ne biniyé Pédrú # iŋ libré  
*'It is to which child that the book was given by Pedro?'*
- (4.3.2.2.4.3.2) iŋ sánuŋ anák # iŋ mágáral  
*'The [person who] is studying is which child [among the children]?''*
- (4.3.2.2.4.3.3) in sánuŋ táu # iŋ mágáral  
*'The [person who] is studying is which man [among the men]?''*
- (4.3.2.2.4.3.4) nánuŋ báge # iŋ gagáwan na niŋ anák  
*'The [object which] is being made by the child is what thing?'*

Somewhat strained but acceptable is:

- (4.3.2.2.4.3.5) nínuŋ táu # iŋ dínatán  
<sup>x</sup>*'The [person who] arrived is who person.' = 'Who is it who arrived?'*

The predicate nouns in all the examples are state V's which are specified by an N with the following matrix:

N  
 selectional units  
 classificatory noun  
 interrogative

Classificatory nouns (which are lexical units in their own right) are super-ordinates under which may be listed more specific sub-classes in a folk taxonomy. Such classificatory nouns are anák 'child', táu 'man', báge 'object', which although lexical units in themselves are likewise super-ordinates to more particular sub-classes of children or men or objects or even to unique instances of children or of men or of objects. In questions such as those exemplified, the classificatory noun is given; the response must fill in the interrogative with a root subordinate to the classificatory noun. Post-semantically, the N matrix which is selectionally specified by a classificatory noun must be linearised as two branches (following rules set down in Chapter II):



- (Sy 3) V  
state  
quantitative  
numerical  
interrogative → pilán 'How many?'
- (Sy 4) V  
state  
quantitative  
numerical  
ordinal  
interrogative+ordinaliser → ikapilán 'In what rank?'
- (Sy 5) V  
state  
quantitative  
numerical  
grouped  
interrogative → makanánu lit. 'How?' = 'In groups of how many?'
- (This matrix is probably better treated as an idiom.)
- (Sy 6) V  
state  
quantitative  
numerical  
instantive  
interrogative+instantiviser → makatapilán 'How many times?'
- (Sy 7) V  
state  
quantitative  
numerical  
interrogative  
individuated → tiyápilán 'How many/much each?'
- (Sy 8) 

V state mensurative interrogative	measure N monetary interrogative	patient	→ magkánu 'How much?'
		V <sub>2</sub>	
			state quantitative numerical interrogative
- (Sy 9) 

V <sub>1</sub>	measure N monetary interrogative	patient	→ tiyámagkánu 'How much each?'
		V <sub>2</sub>	
			state quantitative numerical interrogative individuated

(Sy 10)	<div style="display: flex; align-items: center; margin-left: 20px;"> <div style="border-top: 1px solid black; width: 100px; height: 10px; margin-bottom: 5px;"></div> <div style="margin-left: 5px;">           V state motivative interrogative         </div> <div style="margin-left: 100px; text-align: center;">           motive N interrogative         </div> </div>	→	<div style="display: flex; align-items: center;"> <div style="font-size: 2em; margin-right: 5px;">{</div> <div style="margin-right: 5px;">bákit</div> <div style="margin-right: 5px;">óbákit</div> <div style="font-size: 2em; margin-left: 5px;">}</div> </div>	'Why?'
(Sy 11)	V process interrogative -actual patient subject	→	manánu	'What will happen to ___?'
(Sy 12)	aspect: durative + manánu	→	mananánu	'What is happening to ___?'
(Sy 13)	aspect: completed + manánu	→	<div style="display: flex; align-items: center;"> <div style="font-size: 2em; margin-right: 5px;">{</div> <div style="margin-right: 5px;">ménánu</div> <div style="margin-right: 5px;">nfnánu</div> <div style="font-size: 2em; margin-left: 5px;">}</div> </div>	'What happened to ___?'
(Sy 14)	V process interrogative -actual plural patient subject	→	maṇanánu	'What will happen to (plural)?'
(Sy 15)	V (process) action interrogative -actual agent subject	→	numánu	'What will X do?'
(Sy 16)	aspect: durative + nánu	→	nánánu	'What is X doing?'
(Sy 17)	aspect: completed + nánu	→	nfnánu	'What did X do?'
(Sy 18)	aspect: immediate + nánu	→	kanánunánu	'What did X just now do?'
(Sy 19)	V (process) action interrogative repetitive -actual agent subject	→	maṇnánu	'What will X do repeatedly?'
(Sy 20)	V (process) action interrogative -actual common subject <sub>a</sub>	→	nánan	'What will be done to ___ by X?'

(Sy 21)	V (process) action interrogative -actual instrumental subject	→	ipánnánu	'What will be done with — by X?'
(Sy 22)	N human unique interrogative definite	→	nfnu	'Who?'
(Sy 23)	N human <(unique)> interrogative <(associative)> plural definite	→	nfnunfnu	'Who (associative plural/ plural)?'
(Sy 24)	N interrogative	→	nánu	'What?'
(Sy 25)	N interrogative plural	→	nánunánu	'What (plural)?'
(Sy 26)	N interrogative definite partitive	→	sánu	'Which (among X)?'
(Sy 27)	N interrogative plural definite partitive	→	sánusánu	'Which ones (among X)?'
(Sy 28)	{ location } { source } { goal } N interrogative definite	→	núkarín	'Where? To where? From where?'
(Sy 29)	time N interrogative definite	→	kapilán	'When?'

There is a subset of formatives in Pampangan the symbolisations of which resemble those of interrogative N's; these formatives, are, however, not interrogative although they are likewise not lexically specified. These are forms translatable as 'whoever', 'whichever', and 'whatever'. Instead of having the unit 'interrogative' as part of the N matrix, it seems that these formatives have the specification '-known'. Moreover, they never occur as simple N matrices but must always be accompanied by a restrictive relative clause. 'Whoever' and

'*whichever*' are inflectionally definite; '*whatever*' is unmarked for the specification definite. It may be specified as such, in which case it is accompanied by a determiner. Moreover, these forms may specify any rel N in a sentence and be post-semantically SUBJECT, OBLIQUE, or -SUBJECT and -OBLIQUE. Only examples for '*whoever*' will be cited:

- (4.3.2.2.4.4.1) kalugurán ke # in nfnuman a kalugurán mu  
'[The] *whoever is loved by you is loved by me.*'
- (4.3.2.2.4.4.2) ibiyé me # inf # kiñ nfnuman a atf yu karfn  
'*This is to be given by you to whoever is over there.*'
- (4.3.2.2.4.4.3) gáwan ne niñ nfnuman a atf yu kēni # inf  
'*This will be done by whoever is here.*'

The following symbolisation rules may be given:

- (Sy 30) N  
human  
(unique)  
-known  
definite → nfnuman '*whoever*'
- (Sy 31) N  
human  
<(unique)>  
-known  
<(associative)>  
plural  
definite → nfnunfnuman '*whoever (plural)*'
- (Sy 32) N  
-known  
definite  
partitive → sánuman '*whichever*'
- (Sy 33) N  
-known  
plural  
definite  
partitive → sánusánuman '*whichever (plural)*'
- (Sy 34) N  
-known → nánuman '*whatever*'
- (Sy 35) N  
-known  
plural → nánunánuman '*whatever (plural)*'

4.3.2.3.  $V^{**}$  : *Selective, Confirmative, Re-assurative, Concurative*  
*action*  
*verbal*

4.3.2.3.1. Selective

4.3.2.3.1.1. Disjunctive Questions

In Chapter III, it was shown that a sentence may consist of a disjunction of two or more V configurations:

(4.3.2.3.1.1.1) makó ya # i Suán ## o ## dátaŋ ya # i Maryá ##  
 o ## múli ya # i Pédro  
*'Either Juan will leave, or Maria will arrive,*  
*or Pedro will go home.'*

In the sentence above, the Speaker is stating three propositions but judging only one as true.  $V^*$  is action, verbal, and expressive. There is embedded in complement  $N^*$  a judicial verbal action  $V^{**}$ , and in complement  $N^{**}$ , the semantic propositions are embedded. If, however, one asks:

(4.3.2.3.1.1.2) makó ya # i Suánt ## o ## dátaŋ ya # i Maryát ##  
 o ## múli ya # i Pédro  
*'Will Juan leave, or will Maria arrive, or will*  
*Pedro go home?' [Select one of the three.]*

it is not the Speaker who selects but the Speaker is asking the Hearer to select.  $V^*$  is thus action, verbal, conative. In the complement  $N^*$  is embedded a  $V^{**}$  action, verbal, selective. Semantically, selective is incorporated into embedded V in  $N^{**}$ . Since the rising intonation (†) was hypothesised as signalling disjunction rather than 'selective', it seems that 'selective' is eventually deleted. The same type of situation obtains in sentences with only two clauses in a disjunctive relation:

(4.3.2.3.1.1.3) makó ya # i Suánt ## o ## dátaŋ ya # i Márya  
*'Will Juan leave, or will Maria arrive?'*  
 [Select one of the two.]

4.3.2.3.1.2. Yes/No Questions

A type of question which has received much attention in the literature on transformational generative grammar (undeservedly, it seems to me, since it has distracted attention from other far more interesting question types) is a disjunctive  $\overline{V} V$  configuration in which the second V is identical with the first V except for the additional specification 'negative' of the second V:

- (4.3.2.3.1.2.1) makó ya # i Suánt ## o ## é ya makó # i Suán  
*'Will Juan leave, or will Juan not leave?'*  
 [Select one of the two.]

The above sentence, in pre-semantic structure, is embedded in a complement N\*\* accompanying a V\*\* which is specified as action, verbal, and selective. Because of the -new items in the second V, the following deletions are possible:

- (4.3.2.3.1.2.1') makó ya # i Suánt † ## o ## é ya makó  
*'Will Juan leave, or will he not leave?'*  
 [Select one of the two.]
- (4.3.2.3.1.2.1'') makó ya # i Suánt † ## o ## aíf ya  
*'Will Juan leave, or will he not?'*  
 [Select one of the two.]
- (4.3.2.3.1.2.1''') makó ya # i Suánt †  
*'Will Juan leave?'*

The last possibility is unusual insofar as the negative specification in the second V is new information; it is, however, deletable, probably because the symbolisation of disjunction by † makes the negative alternative redundant. Since the first proposition is a contradictory of the other, to give the affirmative is to imply its negative correlate.

#### 4.3.2.3.1.3. Indirect Questions

In such indirect questions as

- (4.3.2.3.1.3.1) kukután naḡ Pédrú # kaḡ Suán ## nuḡ nánánu ya #  
 i Maryá  
*'It is being asked by Pedro of Juan what Maria  
 is doing.'*

the semantic configuration is:

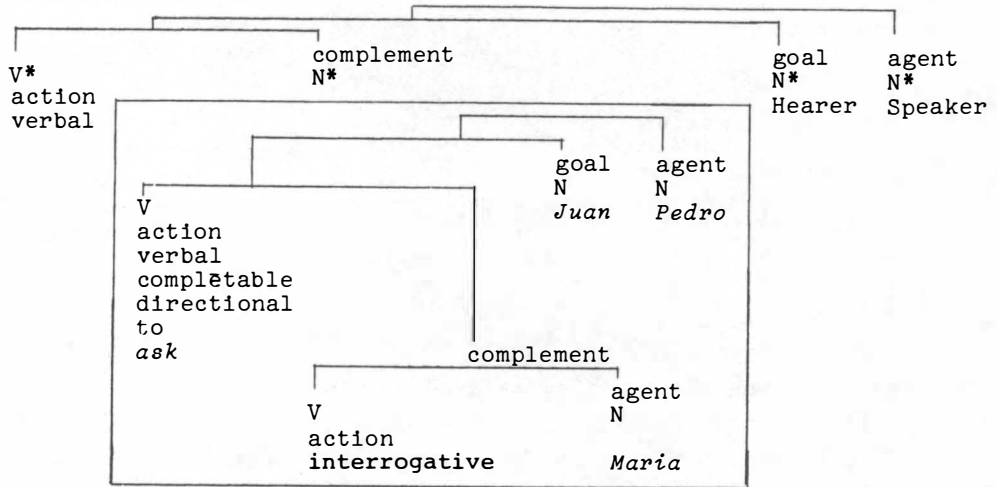

It is possible for the complement of ask to be not merely a V configuration but a disjunctive V V configuration:

(4.3.2.3.1.3.2) kukutáŋ naŋ Pédrú # kaŋ Suán ## nun dátaŋ ya #  
 i Maryá # o # é ya dátaŋ # i Maryá  
 'It is being asked by Pedro of Juan whether  
 Maria will arrive or Maria will not arrive.'

In such indirect questions, V\* is not specified as conative and hence, the unit 'selective' does not arise at all. In fact, there is no V\*\* but a V (with its own embeddings) embedded in a complement N\*. Hence, indirect questions are not questions at all but merely reports.

4.3.2.3.1.4. Summary

The following rules generate disjunctive questions:

- (PS 25') V\*\* action verbal - -> selective / V\* conative
- (PS 26') V\*\* action verbal selective completable ->

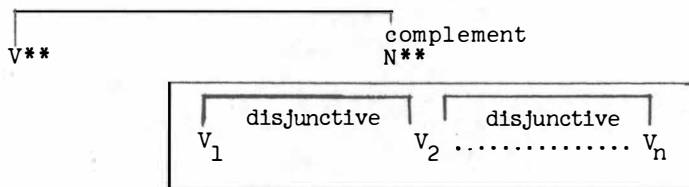

(S 9) V  
 root → selective / V\*\*  
 selective

4.3.2.3.2. Confirmative

Consider the sentences:

(4.3.2.3.2.1) mabágal ya # in áutu ## ne†  
*'The car is slow: confirm this proposition.'*

(4.3.2.3.2.1a) é ya mabágal # in áutu ## ne†  
*'The car is not slow: confirm this proposition.'*

(The symbolisation ne† is likewise used as a signal for checking comprehension, in other words, it is an expression for requesting feedback, especially in explanation. It is loosely paraphrasable as 'Understand?'). The sentences exemplify the following situation: the Speaker makes a statement (affirmative or negative); in turn, he asks the Hearer to confirm his statement. Thus, it seems that the pre-semantic and semantic configuration is:

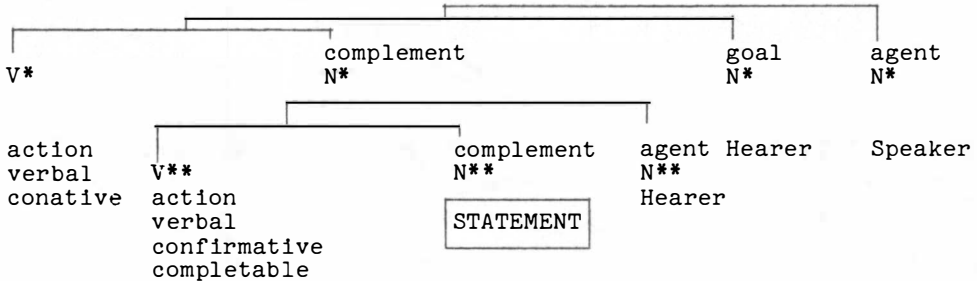

Semantically, 'confirmative' does not seem to be incorporated into V but is directly symbolised by ne† which is placed at the end of the symbolisation for semantic V N (the statement).

An interesting instance of 'confirmative' is exemplified by the following sentence:

(4.3.2.3.2.2) malagu ya wári? # in dalága  
*'I infer that the young woman is pretty:  
 confirm my inference.'*

What seems to happen here is that the proposition 'The young woman is pretty' is the complement to two pre-semantic structures. On the one hand, there is a V\*\* with an N\*\* complement in which the  
 action  
 psychological  
 ratiocinative  
 inferential  
 completable

proposition is embedded. On the other hand, there is a V\*\*  
 action  
 verbal  
 confirmative  
 completable

in which the complement N\*\* has embedded in it the same proposition.

Moreover, the first V\*\* is embedded in a V\* configuration while  
 expressive

the second V\*\* is embedded in a V\* configuration. Semantically,  
 conative

V incorporates the unit 'inferential' and linearises it within the verb phrase; it is symbolised as wári?. 'Confirmative' is deleted and therefore receives Ø symbolisation.

The relevant pre-semantic rule for confirmative questions is:

(PS 27') V\*\* - → confirmative / V\*  
 action verbal conative

#### 4.3.2.3.3. Echoic

Consider the following situation:

(4.3.2.3.3.1) SPEAKER A: malagú ya # in dalága  
*'The young woman is pretty.'*

SPEAKER B: malagú ya # in dalága  
*'Did I hear you right:  
 The young woman is pretty?'*

Note that the utterance of SPEAKER B is homophonous with the question *'Is the young woman pretty, (or is the young woman not pretty)?'* Only the context disambiguates the utterance. In the situation above, SPEAKER B is checking his auditory channels as it were and asking SPEAKER A to confirm his checking. For this type of question, the usual label 'echoic' will be used. The pre-semantic structure demands a V\* which in turn has a complement N\* with an embedded V\*\*  
 conative action  
 verbal  
 echoic

Embedded in complement N\*\* is the repeated message. The unit 'echoic' is directly symbolised by †. The following rule may be formulated:

(PS 28') V\*\* - → echoic / V\*  
 action verbal conative

Consider now the following situation:

(4.3.2.3.3.2) SPEAKER A: biniyé neñ Pédrú # kañ Suán # in átu  
*'The car was given by Pedro to Juan.'*

Now, the Hearer; SPEAKER B, because of some channel noise, might have missed part of the message or the whole message. If he missed the whole message, he will say:

SPEAKER B: \*nánut > nánot  
'What [did you say]?''

If he missed the lexical specification of the agent, he would ask:

biniyé ne nfnót (# kaḡ Suán # iḡ áutu)

If he missed the beneficiary, he would ask:

biniyé ne (+ḡ Pédru) # kanfnót (# iḡ áutu)

If he missed the complement, he would ask:

biniyé (neḡ Pédru # kaḡ Suán) # iḡ nánót

Note that the above sentences use the same formatives as in content questions: N . The rising intonation signals the request  
interrogative

for channel check and the interrogative N, an N with lexical gap, localises the part of the message which needs repeating. What the Speaker is asking the Hearer to do is to fill in a lexical gap which has been missed because of channel noise. An alternative way of expressing echo questions with lexical gaps would be:

nfnu # iḡ miniyé† (# kiḡ áutu # kaḡ Suán)  
'The [person who] gave the car to Juan is who?'

kanfnu ne biniyé† (Pédru # iḡ áutu)  
'The car was given by Pedro to whom?'

nánu # iḡ biniyé nat (+ḡ Pédru kaḡ Suán)  
'The [object which] was given by Pedro to Juan was what?'

The preceding echo questions are homophonous with ordinary content questions except for the marked breath-group, which is clearly a symbolisation for 'echoic'. Note too that in echoic questions, while other N's may be deleted, the verb is always expressed as a kind of support for the N with lexical gap.

In questions which are echoic, V\* is conative, V\*\* is echoic, and the embedded  $\overline{V}$  N configuration of V\*\* contains in addition N matrices with lexical gaps. The hearer is thus asked to specify an N matrix further by supplying the lexical root not heard. For such echo questions with lexical gaps, therefore, another rule must be added:

(PS 29') V\*\* - → specific  
echoic

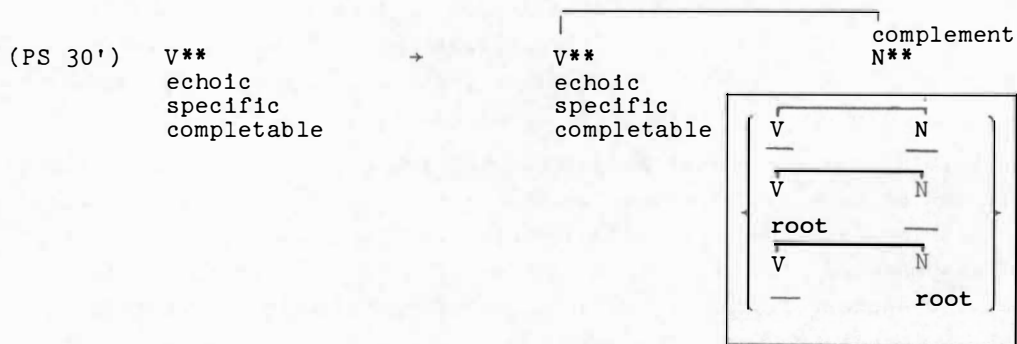

4.3.2.3.4. Re-assurative

Consider the following sentence:

(4.3.2.3.4.1) malagú ya galáñ # in dalága  
 'Is the young woman perhaps pretty?'  
 Paraphrase: '[You tell me that the young woman  
 is not pretty. I am not so sure about this.]  
 It seems to me that she is pretty.'

Again, it seems that a V\* must be posited with an N\* complement  
 conative  
 in which is embedded V\*\* ; accompanying V\*\* is a complement N\*\*  
 action  
 verb 1  
 re-assurative

in which the proposition 'The young woman is NOT pretty' is embedded.  
 The unit 'negative' is deleted, however; instead, 're-assurative' is  
 incorporated into semantic V 'pretty' and then linearised and symbolised  
 as galáñ. The pre-semantic rules may be formulated thus:

(PS 31') V\*\* - → re-assurative / V\*  
 action conative  
 verbal

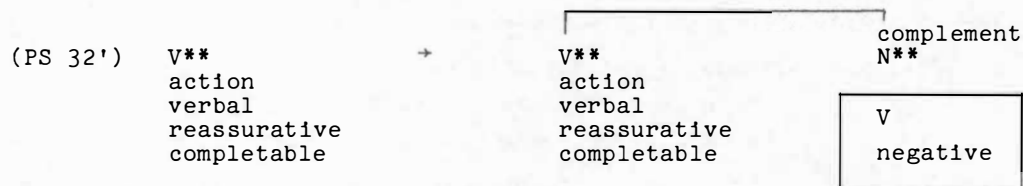

In the sentences:

(4.3.2.3.4.2) SPEAKER A: malagú ya # in dalága  
 'The young woman is pretty.'

SPEAKER B: malagú ya # in dalága † k  
 '[Surprised] Did I hear you right:  
 The young woman is pretty [Re-assure  
 me by saying yes].'

The terminal marker † k is an ad hoc notation for the appropriate facial gestures as well as heightened pitch. It is difficult to characterise the meanings added to the basic proposition 'The young woman is pretty' by this marker. There is definitely an element of surprise (hence, 'super-prehensive'), an intention to check one's auditory channels (hence, 'echoic'), and a request to be assured not that one has heard right but that the proposition is true (hence, 're-assurative'). Moreover, the heightened pitch is probably a signal of 'heightened involvement'; it seems, however, that this heightening of the pitch may be added as a phonological feature of any symbolisation to signal 'heightened involvement'; undoubtedly, it is a residue of man's more primitive communication system. Note that in the preceding sentence, the request to be assured is not added to a negative statement but a positive one: one wants to be re-assured that something is true.

No rules will be formulated to account for sentences of the preceding type. They demand further exploration; perhaps, the notion that a proposition may be shared by several illocutionary verbs will provide a fruitful avenue of investigation.

#### 4.3.2.3.5. Concurisive

Consider the sentence:

(4.3.2.3.5.1) é ya malagú # i Maryá †kk  
 'Is not Maria pretty?'  
 Paraphrase: 'I consider Maria pretty.  
 Agree with me.'

The example should be distinguished from an earlier sentence (see Section 4.3.2.3.2) here repeated:

(4.3.2.3.5.2) malagú ya # i Maryá ## net  
 'Maria is pretty, isn't she?'  
 Paraphrase: 'Maria is pretty. Confirm this.'

In this latter sentence, the notion of opinion does not come up. The proposition is presented as a fact, a fact to be confirmed. To show this even more clearly, a non-state V may be cited:

(4.3.2.3.5.3) dlnatán yá # i Maryá ## net  
 'Maria arrived, didn't she?'  
 Paraphrase: 'Maria arrived. Confirm this.'

In the first sentence cited (4.3.2.3.5.1), there is pre-supposed the Speaker's opinion or judgement that Maria is pretty. The terminal marker is an ad hoc notation: †kk is used instead of † k (the latter was used for 'super-prehensive'). The request for concurrence is accompanied by facial gestures; there is, however, no heightened pitch rise. Moreover, sentence (4.3.2.3.5.1) must be distinguished from:

(4.3.2.3.5.4) e ya malagú # i Maryá†  
 'Did I hear you right: Maria is not pretty?'

which is homophonous with (4.3.2.3.5.1) except for the para-linguistic features. This last example is an echoic question, a request on the part of the speaker checking his auditory channel for the hearer to confirm that he heard right. Moreover, one must distinguish (4.3.2.3.5.1) and (4.3.2.3.5.4) from

(4.3.2.3.5.5) e ya malagú? # i Maryá † k  
 '[Surprised] Maria is not pretty, you say?  
 Did I hear you right?'

which is a combination of 'super-prehensive' and 'echoic'.

Sentence (4.3.2.3.5.1) may be accounted for thus: V\* is conative, with an embedded V\*\* concursive. At the same time, the nuclear semantic proposition is likewise embedded in V\*\* judicial which in turn is embedded in V\* expressive. The negative unit is problematic: the proposition is clearly not negative. Perhaps it is best seen as a literalisation of 'judicial'; 'concursive' is then symbolised by the terminal marker.

The following pre-semantic rules may be formulated:

- |          |                                |      |                             |
|----------|--------------------------------|------|-----------------------------|
| (PS 33') | V**<br>action<br>psychological | - →→ | judicial / V*<br>expressive |
| (PS 34') | V**<br>action<br>verbal        | - →→ | concursive / V*<br>conative |

#### 4.4. SUMMARY

In this final section, the pre-semantic rules earlier formulated will be re-stated. The rules are suggestive and attempt to account only for the citations in this chapter. Moreover, although there has been mention of semantic structures embedded in more than one pre-semantic structure, such instances of 'shared embedding' will not be accounted for by the rules. This whole chapter attempts to grapple with this fascinating area of linguistic research in terms of the model used; because of its exploratory nature, the rules formulated

are tentative at best. It should be noted that the theory lends itself easily to the eventual deletion of these pre-semantic structures since in Chapter II, a general deletion process was formulated by which all (-OBLIQUE) N's and V's which are not lexically specified are deleted.

4.4.1. Re-statement of Rules

(PS 1)	V*	→→	[ action verbal completable directional to ]
(PS 2)	V*	- →→	{ respectful familiar }
(PS 3)	V*	- →→	{ expressive conative }
(PS 4)	V* conative	- →→	precative

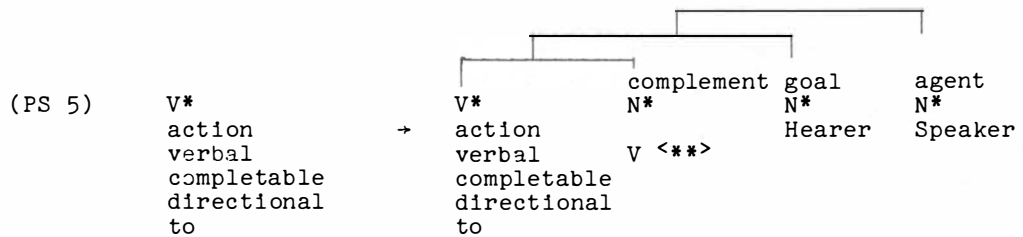

<{ expressive }>  
<{ conative }>

V\*\* is obligatory for expressive, optional for conative

(PS 6)	V**	→→	{ state / V* expressive }
(PS 7)	V** state	→→	experiential
(PS 8)	V** action	→→	{ psychological verbal }
(PS 9)	V** experiential	- →→	{ apparentive informative questive }
(PS 10)	V** informative	- →→	super-prehensive
(PS 11)	V** psychological	→→	{ {ratiocinative} / V* {velleitive}    expressive } {fiduciative} / V* {pretensive}    conative } {suppositive}

- (PS 12) v\*\*  
ratiocinative → {judicial  
inferential}
- (PS 13) v\*\*  
velleitive → {purposive  
optative}
- (PS 14) v\*\*  
verbal → { (exclamative  
concurative  
demurrant) / V\*  
expressive }  
→ { interrogative  
selective  
confirmative } / V\*  
conative }  
→ { echoic  
re-assurative  
concurative }
- (PS 15) v\*\*  
echoic - → specific

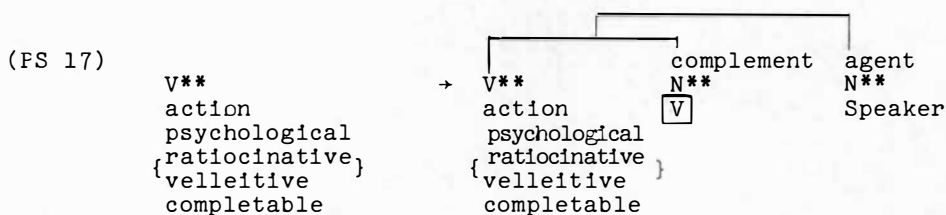
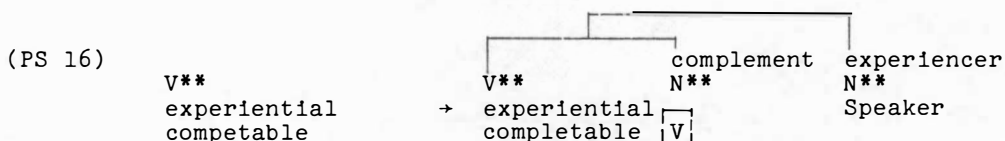

- (PS 18) v\*\*  
action  
verbal  
(exclamative  
concurative  
demurrant)  
completible  
directional  
to →

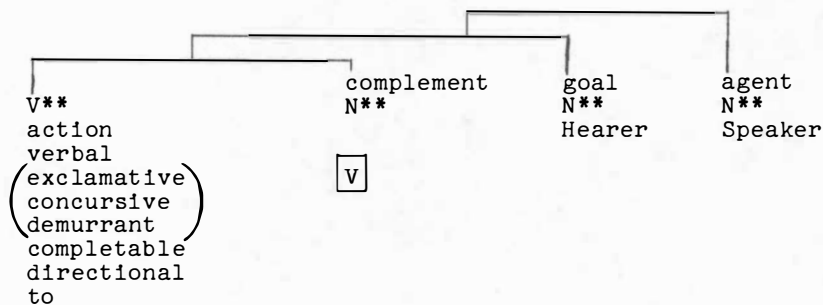

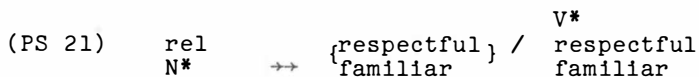
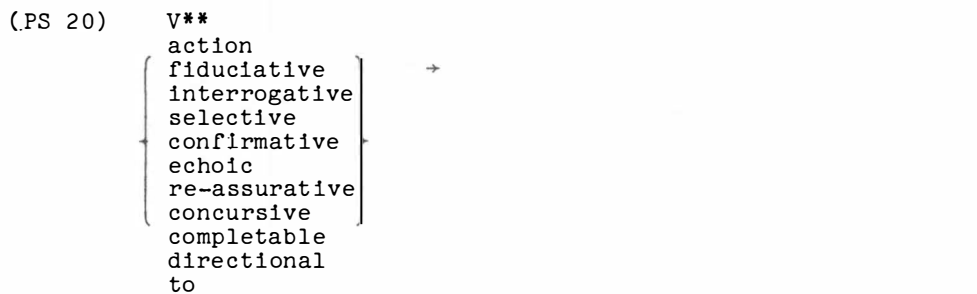
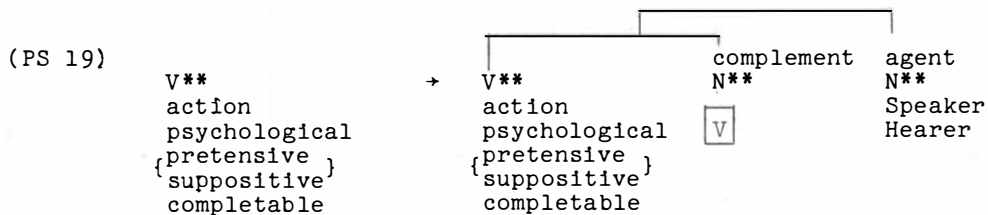

The following diagram summarises the different possibilities schematically; the co-occurrence restrictions, however, are found in the rules themselves.

PRE-SEMANTIC STRUCTURE

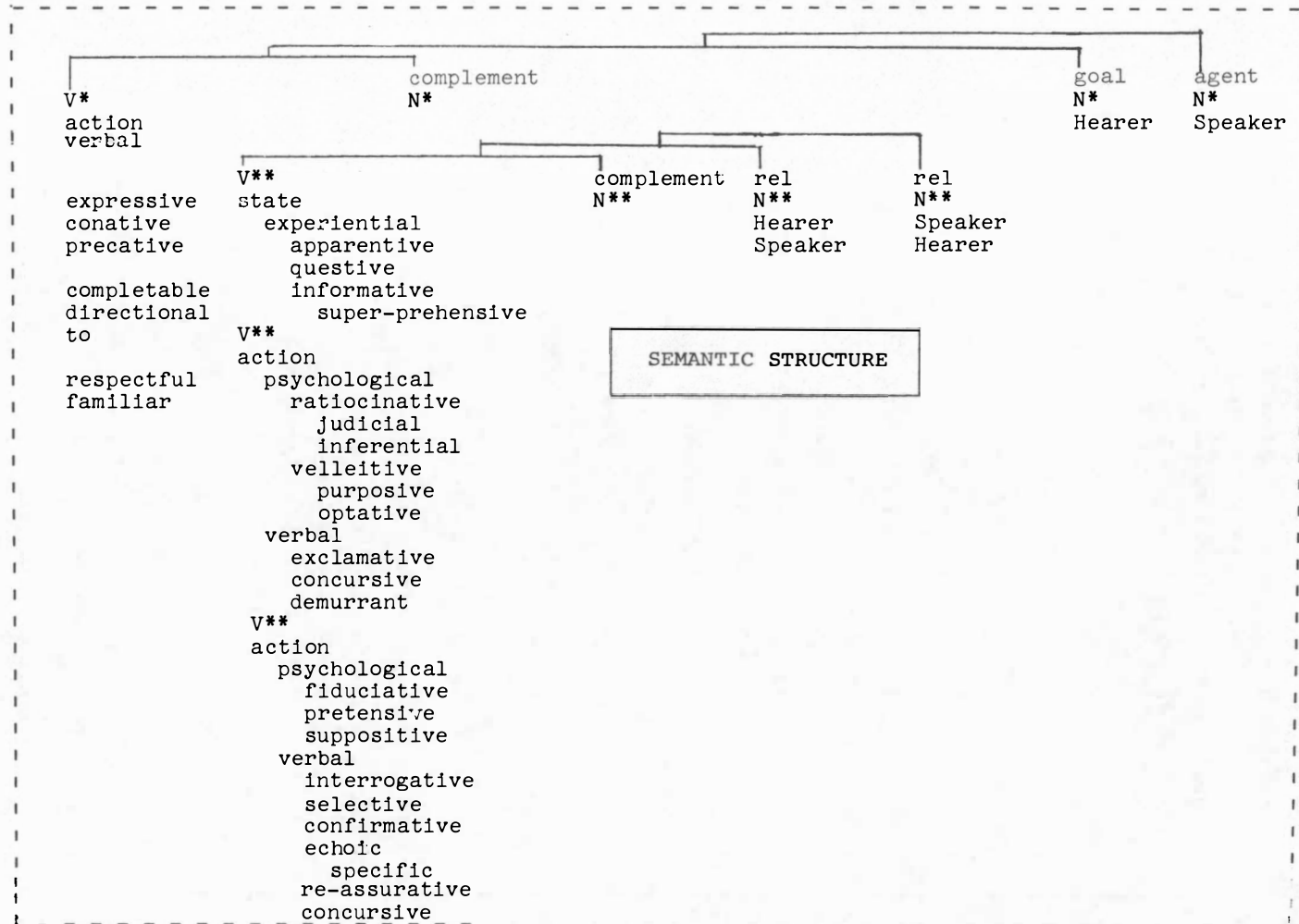

## 4.4.2. Exemplification

By way of summary and example, a sample discourse will be cited and then analysed pre-semantically and semantically. Post-semantic processes will not be discussed. The sample discourse will exemplify many of the configurations discussed, and demonstrate the necessity of intersentential connections that must be posited for an adequate account of discourse.

## DIALOGUE

SPEAKER A kéta puŋ lúnis ## mígkapistá pu? # kiŋ Pampáŋga  
*that Sir Monday was fiesta Sir in Pampanga*  
*'Last Monday, Sir, there was a fiesta in Pampanga.'*

kasantín na pú? niŋ pistát  
*how enjoyable it Sir fiesta*  
*'How enjoyable the fiesta was, Sir!'*

mintá kayu pú? sána # karín  
*went you Sir wish there*  
 plural  
*'I wish you had gone there, Sir.'*

óbákit é kayu pú? mintá  
*why not you Sir went*  
 plural  
*'Why did you not go there, Sir?'*

SPEAKER B okupádu katá kasí  
*occupied you because*  
 I

*'Because I was busy.'*

masantín palá # in pistá  
*enjoyable so the fiesta*  
*'So the fiesta was enjoyable.'*

muntá katá sána  
*go you tentative*  
 I

*'I intended to go.'*

sabiyán mu na mó kékatá # nuŋ nánu in milyári karín  
*tell you kindly to you what the happened there*  
 me

*'Kindly tell me what happened there.'*

From the use of *pu?* and the pluralisation of 'second person', it is obvious that the first speaker (SPEAKER A) is lower in social rank (or younger) than the second speaker (SPEAKER B). On the other hand, from the use of the pronoun '*You and I*' to refer to himself, SPEAKER B is trying to be familiar with SPEAKER A. Perhaps he is a politician trying to ingratiate himself with a common person.

The pre-semantic and semantic structure of the first sentence may be represented thus:

- (A 1)      *kéta puŋ lúnis mfgkapistá pú? kiŋ Pampánga*  
               '*Last Monday, Sir, there was a fiesta in Pampanga.*'

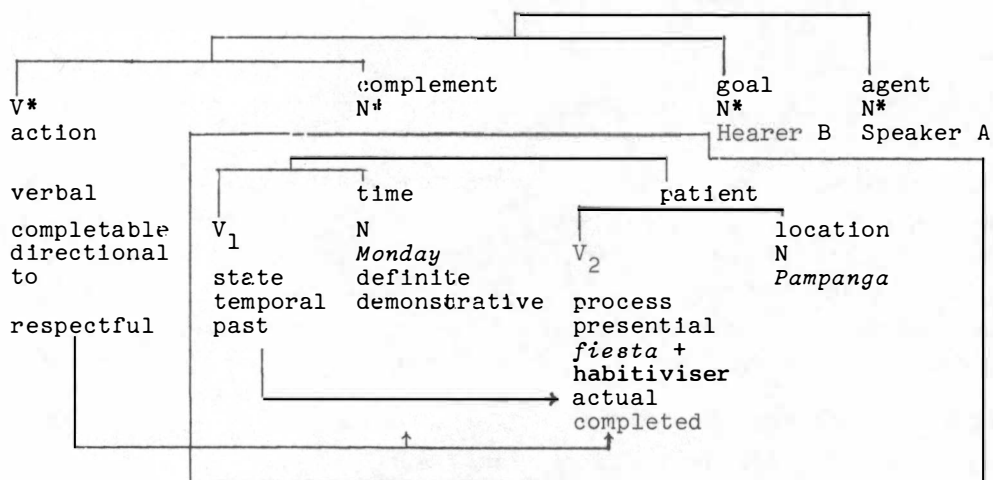

The first sentence consists of a temporal state V specified as past without a lexical root; it is accompanied by a time N and a patient N. The patient N is a V configuration consisting of a presential process V. Presential verbs, it was stated in Chapter I, may be accompanied by a location N and usually by a patient N; in this instance, however, by a derivational process, what would normally be a patient N has been incorporated into the derived process V. Note that 'respectful' must be included in both the accompanying time and patient. Moreover, 'past' specification in  $V_1$  dictates actual completed aspect in  $V_2$ .

Consider now the second sentence:

- (A 2)      *kasantŋ na pú? niŋ pistát*  
               '*How enjoyable the fiesta was, Sir!*'

The structure may be represented thus:

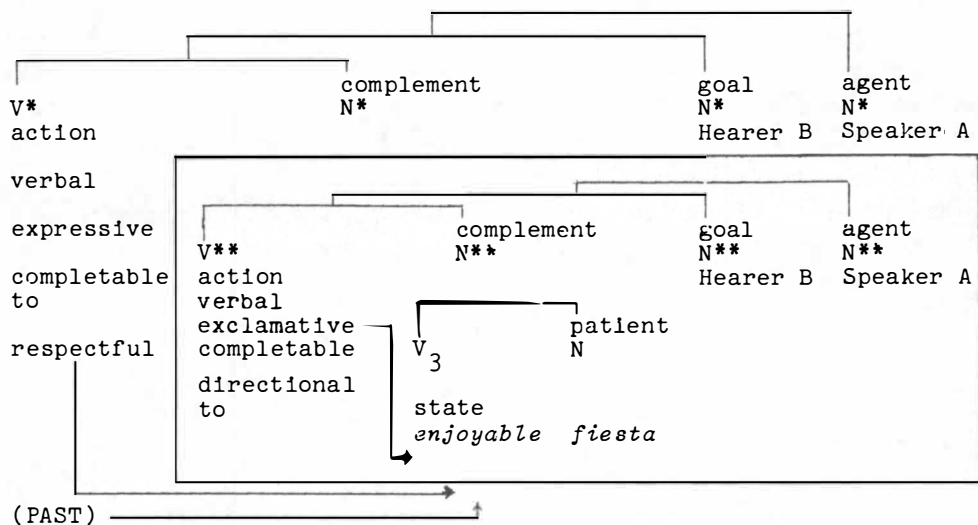

The second sentence is a simple state V embedded, however, in an exclamative V\*\*. Note that 'respectful' is carried over from the preceding sentence into V\* and semantically into V<sub>3</sub>. Moreover, 'exclamative' is incorporated into V<sub>3</sub>. Finally, although there is no overt marking, it is implied that the state occurred some time in the past, from the past specification of V<sub>1</sub>.

(A 3)        mintá kayu pú? sána karín  
               'I wish you had gone there, Sir.'

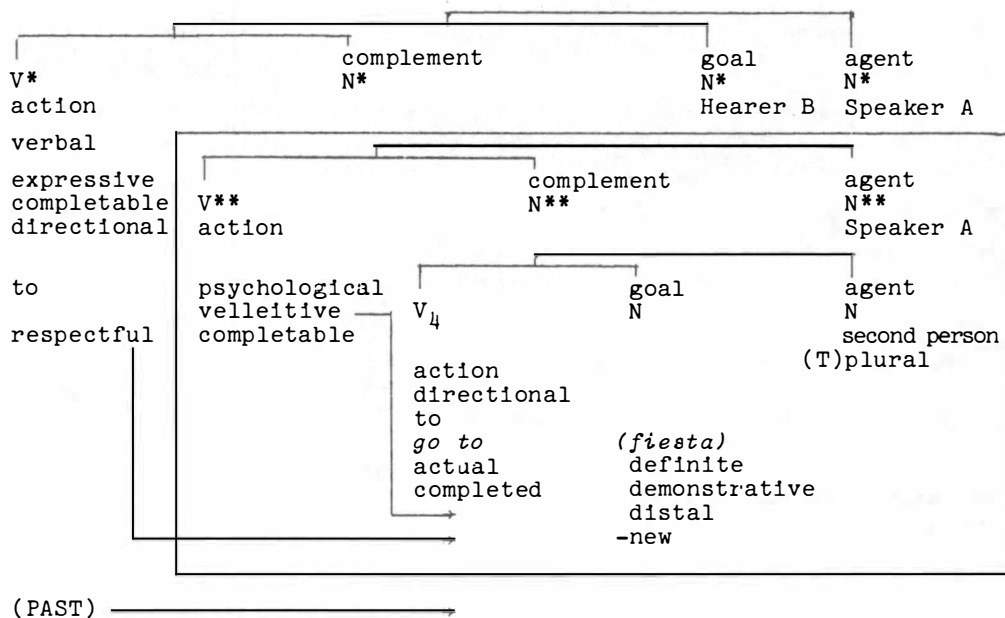



'plural' specification of agent N. Once more, 'past' dictates that V<sub>6</sub> be actual completed.

The sentence uttered by SPEAKER B may be analysed thus:

(B 1) okupádu katá kasí  
 'Because I was busy.'

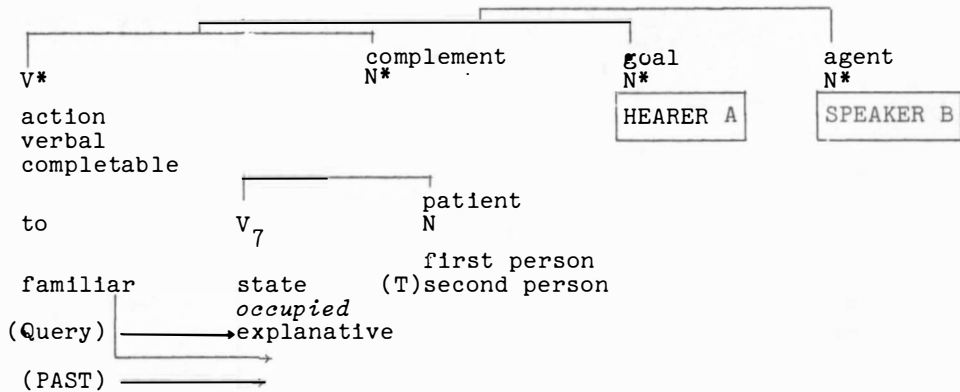

The first sentence of SPEAKER B is an answer to the question of SPEAKER A; because of this, 'explanative' is included as a specification of V<sub>7</sub>. The familiar tone is initiated in this new discourse unit and is carried into V<sub>7</sub>; it has no overt reflex other than the post-semantic (T) specification of 'second person' of patient N. Again, 'past' is carried into the continuation of the discourse although it has no overt reflex since V<sub>7</sub>, a state V, is not specified for aspect relative to time.

(B 2) masantíη palá # in pistá  
 'So the fiesta was enjoyable.'

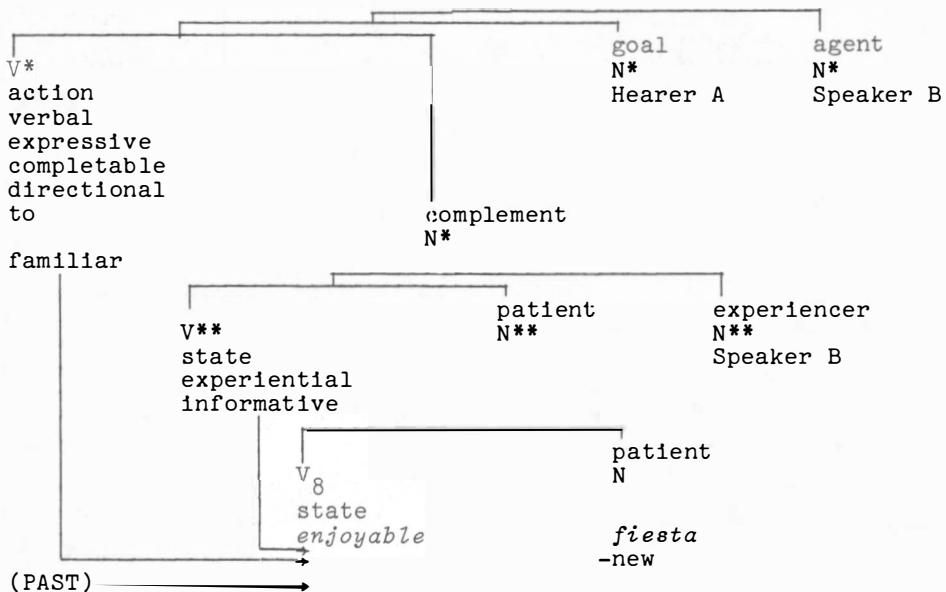

Although '*fiesta*' is -new, perhaps because it is the first time that SPEAKER B is referring to it, it is not deleted. 'Familiar' and 'past' are carried over but have no overt reflexes. The unit 'informative' is incorporated into  $V_g$ .

- (B 3) muntá katá sána (# karfn)  
'I intended to go (there).'

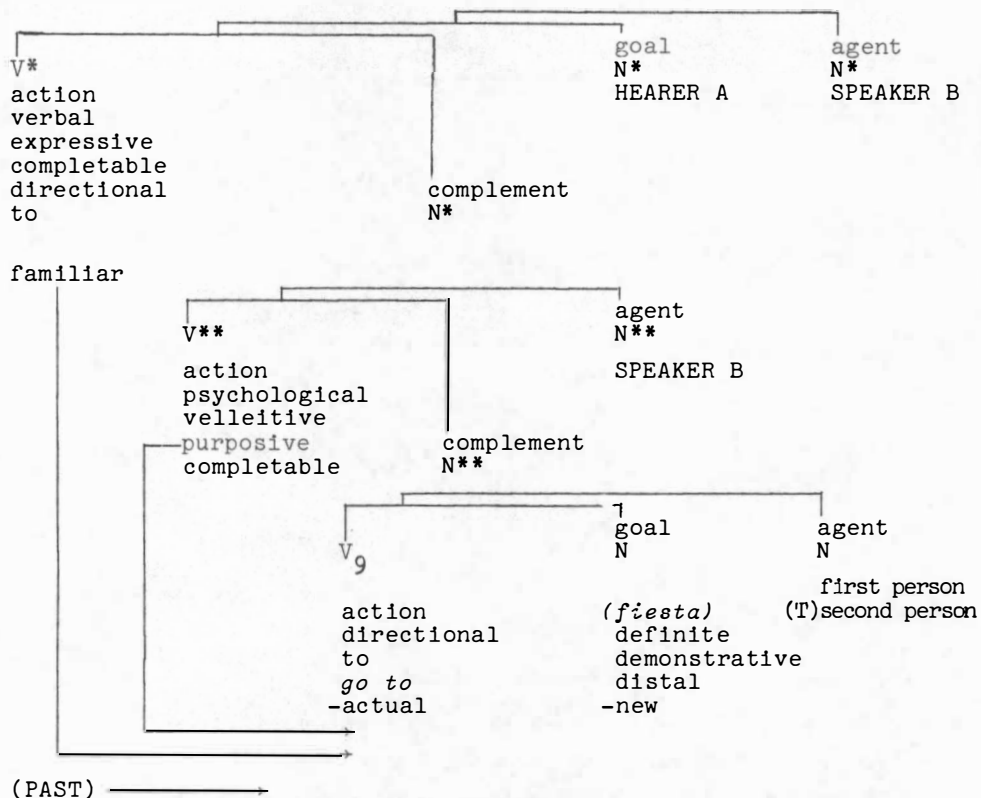

The sentence expresses an intention that was never carried out. The goal is -new and is deleted outright. Again, 'familiar' is carried over into semantic structure and post-semantically (T) causes the addition of 'second person' to the agent N. Moreover, 'purposive' is incorporated into  $V_g$ . Note, however, that the aspect is -actual, although the intention is still localisable in the past. It seems that in semantic structures which are embedded in  $V^{**}$  purposive, 'past' is incorporated into  $V^{**}$  but not into semantic V, which is aspectually unmarked (-actual).

- (B 4) sabiyán mu na mó kékátá # nuñ nánu in milyári karfn  
'Kindly tell me what happened there.'

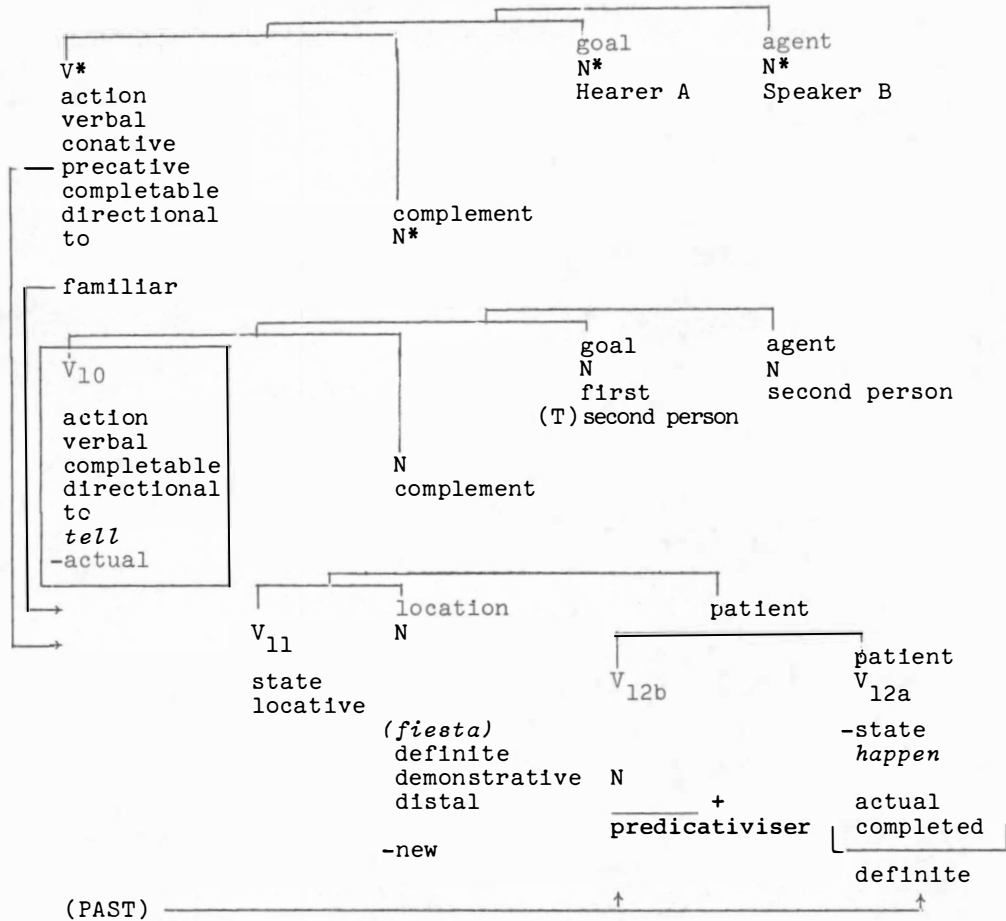

(B 4) expresses a request. Since the illocutionary V is neither expressive nor conative, there is no embedded V\*\*. Rather, the complement N\* is a verbal action V with its own complement, which in turn consists of a locative state V accompanied by a location N and a patient N. The patient is unusual:

nánu iḡ milyári  
lit. 'the [event which] occurred is what.'

Independently,

nánu # iḡ milyári

means

'What happened?'

maliyári lit. 'to happen' is a classificatory verb for any non-state V. The expected answer to it is some non-state V which is then accompanied by its own N's. The whole patient sub-configuration is definite.

Again, 'familiar' is carried into the sentence from the initial (B1) sentence and post-semantically (T) causes the additional specification of 'second person' to the goal N matrix. 'Precative' is incorporated into  $V_{10}$ ; moreover, 'past' dictates that the aspectual specifications of  $V_{12a,b}$  be actual completed. Since the location N accompanying  $V_{11}$  is -new, the root is deleted, leaving a locative pro-nominal '*there*'.

The analysis shows how initial 'social tone' must be carried through every sentence in the discourse unit and how this specification is incorporated into the semantic structures and post-semantically causes certain additions of units. Moreover, it likewise shows how certain pre-semantic units must be incorporated into V; inter-sentential connectors which link the discourse units together must likewise be incorporated into subsequent V's. Finally, the temporal placing of the event '*fiesta*' in the past, expressed by the first sentence, incorporates 'past' into all the relevant non-state V's, and although unexpressed, into the state V's as well, thus explaining why the glosses are in the past tense, except when a V is embedded in a purposive V\*\* (it is then -actual).



## CHAPTER V

### REVIEW AND PREVIEW

#### 5. INTRODUCTION

This chapter, by way of summary and conclusion, reviews the main findings of the study. The first section summarises conclusions on the principal topics discussed; the second section discusses hypotheses and proposed analyses which in some ways depart from or are meant to be an extension of Chafe's theory, especially the proposals of Chapter IV, where the notion of pre-semantic structure was introduced. The third section surveys four important studies of Pampangan and reviews certain of their conclusions in the light of the findings in this study. Finally, areas of future research suggested by this study will be outlined.

#### 5.1. GENERAL CONCLUSIONS

Following the model proposed by Chafe, the basic sentence configuration is considered as generated by initial V, which is specified further for selectional units which narrow the lexical choice to a particular lexical unit (basic or derived). In turn, this lexical unit is specified further for inflectional units. On the basis of the selectional and inflectional units of V, accompanying N's are postulated, N's in different relations to V; in turn, these N's are specified further by selectional, lexical (basic and derived), and inflectional units.

The most important selectional specifications of V are those of state, process, and (process-)action; these sub-types of V may be further specified by other selectional units. Such selectional units typically necessitate a special type of accompanying N.

The following N relations (*vis-à-vis* V) were discovered: agent, experiencer, agentive beneficiary, instrument, complement, measure, patient, beneficiary, material, norm, associate, partitive, source, goal, location, and time. This inventory increases the list suggested by Fillmore (in his study of 'deep structure' cases) and by Chafe.

In general, the selectional and inflectional units discovered for Pampangan are similar to those discovered for Onondaga and for English by Chafe. The mode of combination of these units as well as their post-semantic behaviour are, of course, different. In Pampangan, tense and aspect specifications are kept separate. Aspectual specifications are inflectional units specifying non-state V's and a small sub-set of state V's; one type of aspectual specification, 'generic' is a possible inflectional unit for both state and non-state V's. Tense specifications, on the other hand, are selectional units of state V's specified as temporal. Where an utterance contains both tense and aspect specification, it is usually a  $\overline{V} \quad \overline{V}$  configuration or a V configuration with an incorporated tense specification from a previous temporal state V. Among the units specified for N, the only specification that was peculiar to Pampangan was 'associative plural', a possible inflectional specification for unique N's.

Pampangan shows its most distinctive characteristics in the area of derivational units and of derivational processes. It was demonstrated that the possibilities for agglutinative combinations of noun and verb roots with prefixes, infixes, and suffixes are formidable. Rather than seek what Sapir (1921) calls the 'invariant word' (symbolisation), Pampangan seeks variant words, roots with a multitude of possible variants (in symbolisation) through affixing. The semantic treatment of affixes in Pampangan, within an integrated grammatical study, provides one of the most challenging tasks of Pampangan (and Philippine) linguistics; its treatment will undoubtedly make a significant contribution to the general theory of lexicology. Such treatment must of course go beyond mere listing (there are ample lists in Bergaño and in the publications of the Institute of National Language, Manila) and integrate such lists as rules in a grammar.

It was found that the above N relations ultimately reduce to three types in surface structure: SUBJECT, OBLIQUE, and unmarked (-SUBJECT and -OBLIQUE). Moreover, it was likewise discovered that there seems to be a limit in semantic structure to the number of N's accompanying V. It was hypothesised that this constraint was partially conditioned by the limited number of surface markers (the determiners) and hence showed a tendency to avoid constructional homonymity. An optimally specified V can contain in surface structure one subject, one or two

oblique-marked nouns, and one unmarked noun. There may be other oblique-marked nouns in surface structure, but these oblique-marked nouns are ultimately traceable to separate state V's in semantic structure; such instances are labelled in traditional grammar 'sentential adverbs' and 'adverbial phrases'.

The three surface N types correspond to Bloomfield's (1917) three 'cases' (Bloomfield calls these 'cases in a very wide sense' 1917:161): subjective, disjunctive, and local) as well as to Lopez's (1941:53) three cases (nominative, attributive, and locative). These cases were postulated by both Bloomfield and Lopez for Tagalog, but they are applicable to Pampangan. Bergaño, using Latin as a model, remarks:

...tiene esta lengua su distinción y variación de casos; porque así como en el singular de genu, siendo todos los casos una misma voz invariable, se halla el nominativo, genitivo, dativo, etc., según la preposición or artículo que se la antepone; así también los nombres de esta lengua se varían por casos, según el artículo que les precede (5).

He lists the following casos: nominativo, genitivo, dativo, acusativo, vocativo, and ablativo.

On the notion of subjectivisation, it was shown that a distinction must be made between 'subject' and 'topic'; the latter triggers a preposing process. Except in initial discourse and in certain well-defined conditions, the subject N is usually specified as -new (or old) information. Hence, in discourse, one of the functions of subjectivisation is to link a sentence with a preceding sentence; moreover, because the subject N is usually -new in such instances, it is deletable. On the other hand, topicalisation consists of highlighting or emphasising an N; hence, even if an N specified as TOPIC is -new, it is never deleted.

The failure to distinguish between subject and topic has resulted in some confusion. For example, Blake, as early as 1906:186, remarked: 'In Tagalog in a verbal sentence, that adjunct of the verb which is of most importance in the eyes of the speaker or writer is made the subject of the sentence'. It is difficult to see how something which is so readily deletable can be 'of most importance'. It seems that Bloomfield, with his usual uncanny insight into languages even in those which he himself did not speak, captured the notion of subjectivisation in the Philippine languages much better when he remarked. (1917:93; emphasis mine):

In general the choice between these four constructions [active, direct passive, instrumental passive, local passive] is made in accordance with the logical situation: the definite, known object underlying the predicate as starting point of discourse is chosen as subject...

Moreover, the phenomenon of subjectivisation, which has often been mentioned in the scholarly literature as one of the distinctive features of the Philippine languages, is really not that distinctive. The possibility of different 'voices' (different subject choices) is quite common in the languages of the world. What makes Pampangan (and the other Philippine languages) interesting is that these voice markers are overtly marked (see McKaughan 1962) by affixes, affixes which have been shown not to govern the subject but pre-suppose subject choice and are governed by such subject choice, being introduced post-semantically into V by an incorporation process following prior specification of one of the N's accompanying V as SUBJECT. The whole process is comparable to N-V (in Pampangan surface structure, usually V-N) agreement, a post-semantic process quite widespread among the languages of the world. Whether or not one chooses to consider the possibility of different subject choices in a basically identical semantic configuration as an instance of the etic-emic distinction, as Pike (1963) does, depends on whether or not one finds this distinction useful in an area outside of phonology.

Traditional adverbs (manner, time, location, benefaction, motivation, instrument; sentential) were considered to be separate state V's specifying another V further or predicated of a  $\overline{V \ N}$  configuration. Negative was treated as an inflectional unit of V. Instances of embedding were considered as developments in N: either a  $\overline{V \ N}$  sub-configuration in lieu of an ordinary N (complementation) or a  $\overline{V \ N}$  sub-configuration attached to an N (relativisation) specifying an N further quasi-inflectionally. Factitive clauses were treated as embedded  $\overline{V \ N}$  configurations, the whole configuration being inflectionally specified as definite. Nominalisations were considered as generated in semantic structure by an operator labelled NOM added to V in an embedded structure; in surface structure, nominals appear as lexical units with the components verb root + nominaliser.

Finally, the notion of pre-semantic structure was proposed to explain certain phenomena in Pampangan (mostly particles incorporated into semantic V) which otherwise would not lend themselves to clear and orderly exposition. It was proposed that underlying every speech act is a pre-semantic directional (to) completable verbal activity V\* with an accompanying goal N\* (the Hearer), complement N\* (the message), and agent N\* (the Speaker). Embedded within complement N\* is the actual semantic structure. Moreover, where V\* is specified as expressive and in certain instances where V\* is specified as conative, there is another V\* embedded in the complement N\* which in turn may receive its own

specifications as well as accompanying N\*\*'s. In such cases, the semantic structure is embedded within the complement N\*\* of V\*\*. It was within this frame of reference that other sentence types (imperatives, requests, exclamations, questions) were accounted for, to distinguish them from statements or declarative sentences. Semantic structures embedded in such pre-semantic configurations could, of course, consist of more than one V, of equal or unequal rank.

## 5.2. PROBLEMATIC QUESTIONS

The outline has followed Chafe's proposals for the most part. In the following areas, however, the study has departed from Chafe 1970a, b:

(1) It has increased Chafe's inventory of N relations. Since Chafe himself did not intend his list to be exhaustive, the postulation of additional N relations is not unexpected. Moreover, as new data are gathered, the list proposed for Pampangan can be augmented. Ultimately, of course, these N relations or 'deep structure cases' must be syncretised in surface structure. The usefulness of distinguishing between a patient and an object (on the one hand, an N which 'suffers' change of some kind, and on the other hand, an N which is 'just there' and is not affected) needs further investigation; in this study, these N relations were treated as one.

(2) Chafe analyses adverbs of manner by means of the following configuration:

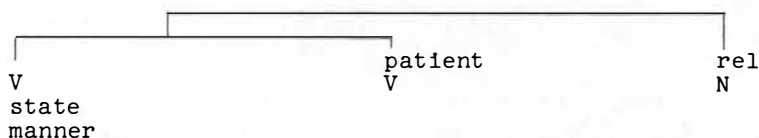

In this study, manner adverbs and certain adverbs of frequency and instance are analysed by means of the following configuration:

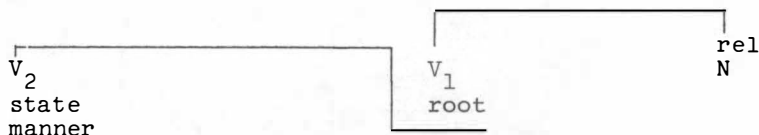

This configuration was proposed to highlight the subordinate character of  $V_2$  as well as to show the absence of direct relation between  $rel\ N$  and  $V_2$ . Thus, manner and frequency/instance adverbs are considered as quasi-inflectionally specifying a nuclear V which has already been specified as to root. The configuration likewise shows the independent status of  $\overline{V_1\ N}$  as opposed to the dependent status of  $V_2$ .

(3) With Chafe, other types of adverbs (including sentential adverbs) were considered as state V's predicated of a  $\overline{V \ N}$  configuration which was in a patient relation to the state V. Besides the patient relation, however, in many instances where the state V was not lexically specified, there was in addition another N relation:



In Pampangan, the possibility that an embedded  $\overline{V \ N}$  relation may be inflectionally specified as definite must be posited, to generate factitive clauses as well as instances of complementation in which the whole complement (an embedded  $\overline{V \ N}$ ) is subjectivised, so that the following sub-configuration must be established as a possibility:

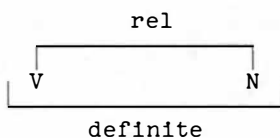

Complementation would then consist of the following structure:

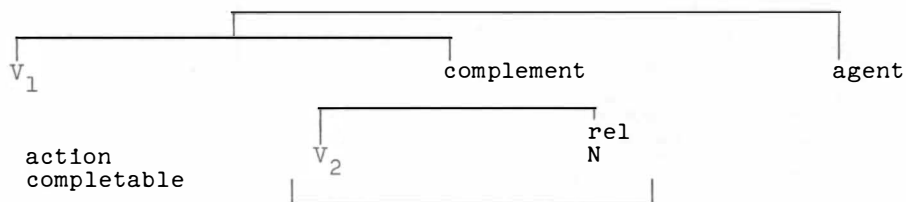

On the other hand, nominalisation would consist of exactly the same sub-configuration (as complement) but with the addition of NOM (which triggers a special post-semantic process):

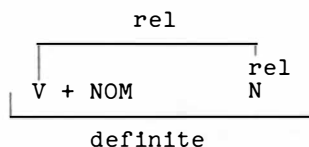

(4) The treatment of relativisation is based not on Chafe 1970a, b but on later (unpublished) work by Chafe. Thus, where Chafe 1970b would analyse relative structures thus:

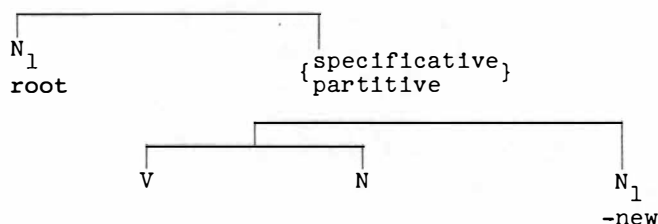

the revised configuration that would be proposed would be:

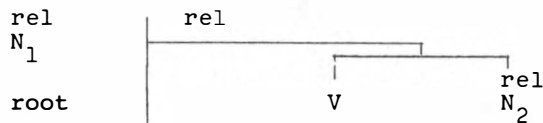

The revised configuration attempts to show that relative clauses in some ways inflectionally specify an N. Moreover, the positing of such a configuration renders deletion of a second  $N_1$  (-new) unnecessary, since  $N_1$  occurs only once. In terms of eventual linearisation in Pampangan, the diagram captures better what seems to happen in Pampangan.

Likewise, the proposal that an optional selectional unit (represented as 'verb root + selectiviser') of a unique N may be highlighted by a relative clause (as in '*Big Pedro*') is novel.

(5) Chafe considers numbers as inflectional specifications of N. In the study, I propose that when an N is specified inflectionally as quantitative, there is an additional replacement rule whereby

N becomes  
 root  
 quantitative  
 numerical/estimative  
 number /much  
 many

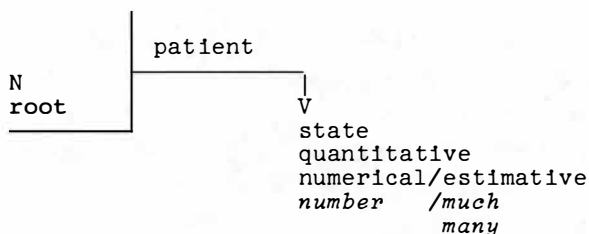

The justification for considering numbers and words of quantitative estimate such as 'much' and 'many' as separate state V's arises from the occurrence of such sentences in Pampangan as:

(5.2.1) aduá la # diŋ táu                    *'The men are two [in number].'*

as opposed to

(5.2.2) atŋ aduáŋ táu                    *'There are two men.'*

(6) Where the study has differed from Chafe's model in a substantive manner is in its proposal concerning pre-semantic structure. Actually, however, rather than a departure from the model, the positing of pre-semantic structures can be considered as ONE possible development of the model.

The units I have posited in Chapter IV as arising from pre-semantic structure Chafe would include directly as either inflectional units of V in semantic structure or (in the case of interrogatives) as a selectional specification 'interrogative' of V or N in lieu of a missing root. In this study, such units are treated likewise as either inflectional units or as selectional units in lieu of a root (in the case of content questions), but a pre-semantic structure is posited as a context. Hence, these units are seen as not so much generated directly but incorporated from a prior generative rule.

I have found the postulation of pre-semantic structures necessary to account for respectful and familiar language as well as to account for the implied Speaker-Hearer shifts in expressive and conative functions of language.

While Ross (1968) uses instances of reflexive use in English as cogent evidence for a declarative performative abstract verb, I have used respectful and familiar language and the array of particles in the verb phrase as evidence for illocutionary verbs in Pampangan, since it is the latter type of evidence that seems most available in Pampangan for positing frames more abstract than the semantic structures posited in Chapters I and III. The illocutionary verbs (V\* and V\*\*) posited in Chapter IV are comparable to the abstract verbs posited by R. Lakoff (1969) for Latin complementation and to the verbs of Sadock's (1969a,b) 'hypersentences' and 'superhypersentences'.

It must be emphasised, however, that the pre-semantic units hypothesised, unless they are coded in semantic structure, are never symbolised. Hence, while paraphrase has been used as a heuristic device, the characterisation of pre-semantic structure consists of pre-semantic selectional units which are not lexicalised or symbolised unless these units are incorporated into V or N. One of the merits of Chafe's model is precisely the distinction made between selectional and lexical units on the one hand and lexical specification and symbolisation on the other hand. The two distinctions help to characterise pre-semantic units quite neatly: they are semantic selectional units which are not

lexicalised; they are symbolised only if they have been incorporated into semantic matrices. Moreover, the general deletion rules postulated in Chapter II whereby any V matrix or non-oblique N matrix which is not lexically specified is deleted makes a similar deletion of such non-lexically specified V\*/V\*\* and N\*/N\*\* matrices all the more plausible.

What makes the postulation of pre-semantic structures attractive to me is that it integrates traditional notions concerning functions of language other than cognitive (expressive and conative) in a total theory of language (consisting of semantic and phonological structures in Chafe's model), which in turn integrates the work of componential analysis in anthropological linguistics within a generative frame of reference in grammar.

It might be objected that the positing of illocutionary verbs smacks of what Firth (1957:21) calls 'the personification of categories' or what he would call 'the hypostasization of paraphrase', to adapt a term he used when he accused Americal structural linguists of 'the hypostasization of the letter' in their different versions of phonemic theory.

My earlier qualifications with regard to the proposal attempts to avoid such 'hypostasization'. The proposed pre-semantic structures make no claim to psycholinguistic reality other than the fact that the matters they seek to account for must somehow be processed by the language performer. The structures are postulated as convenient fictions; they are, to borrow Dempwolff's (1925-6) label for his reconstructions, mere Kunstgriffe, useful for presenting the data in a unified and orderly fashion.

The manner of representation and the notation as well as the attempted formalism (through the formulation of pre-semantic rules) are of course by way of proposal. Where a more viable manner of dealing with such phenomena in an integrated grammar is discovered, then that manner should be adopted. But that such phenomena (social tone, expressive and conative functions) must be accounted for in a grammar seems to me indisputable; no theory of language can be considered adequate unless it accounts for these fascinating and intriguing functions of language.

### 5.3. REVIEW OF SCHOLARSHIP

In the introduction, it was stated that relatively little published scholarship on the structure of Pampangan is available. The available works (Bergaño's pedagogical grammar, Castrillo's survey of main construction types, Lopez's comparative studies of surface structure features, and Constantino's survey of twenty-six Philippine languages and their sentence patterns) will be reviewed informally and their conclusions compared with the findings of this study.

### 5.3.1. Bergaño

Bergaño's (1916) *Arte* is a treasure-trove of data for semantic analysis not only of eighteenth-century Pampangan but also of contemporary Pampangan, since the language has changed very little since Bergaño's period.

The changes that have taken place consist for the most part of accentual modifications and changes in the lexical inventory together with the addition of minor phonological rules.

Many of Bergaño's citations of complex sentences are linguistically interesting, since in my own idiolect and in the idiolects of my informants, such sophisticated structures would seldom arise in ordinary conversations.

Bergaño's aim was pedagogical:

A este fin...apliqué la cortedad de mi talento, reduciendo a reglas, por do puedan gobernarse los ministros, los modos de hablar de vna lengua mas incognita a nosotros, que lo fue la de los Egepcios a Joseph (viii).

Like other missionary grammarians of the period, Bergaño used Latin-based grammars as his model: 'Por conformarme en todo lo posible el arte de la lengua latina, trato, seguido a los nominativos del verbo, sum, est, fui...' (22). From a semantic viewpoint, Bergaño was still very much under the influence, even in the eighteenth century, of the medieval modalists (see Robins 1967), for he speaks of significación and modo de significar:

Advierte, que no es lo mismo con una misma significación que con un mismo modo de significar, mira y nótaló bien. Es verdad, que el verbo ilub primera, lubán segunda, luban tercera, siempre tiene una misma significación, que es entrar,...; pero cada pasiva tiene su diverso modo de significar (64).

In medieval parlance, 'enter' is the substantial or essential meaning (significación); the variant meanings of 'enter' resulting from affixal augmentation are the accidental meanings (modos de significar). In this study, these 'accidental meanings' are added to the root as further specifications. It might be noted that Bergaño's distinction between significación and modo de significar is comparable to Pike's emic/etic distinction.

For a foreigner, Bergaño had an amazing knowledge of Pampangan. Hence, while one may not agree with his model or his analysis and presentation, his data are impeccable. (It is difficult to evaluate his accentuation properly, since this is an area where quite a few changes seem to have taken place. His 1917 editors, moreover, took the liberty of revising these accentuations in the name of modernisation, rendering access to the original difficult; see the editors' remarks on pages iii and iv, 'Dos Palabras sobre esta Tercera Edición'.) From a theoretical

viewpoint, the grammar retains the same validity that any Latin-based analysis of another language has. Nouns are declined, five cases (six, including vocative) are posited, verbs are conjugated, tense and aspect are treated together, and three passives are discussed. His treatment of affixes is typical of any taxonomic-based model. He devotes entire chapters to individual affixes (and their combinations) and lists the multitude of diverse meanings that such affixes may have, in the meantime complaining of the homonymy evident in the language, 'siendo tan diversas las inteligencias' (63). His keen understanding of the language makes him aware of nuances of meaning and ambiguities which I, as a native speaker, never realised until I started detailed analysis. Moreover, his Latinate labels for such semantic units I have adopted where possible, since they fitted very well into my own Latinate scheme of labels.

Bergaño was quite cognisant of the different expressive units with which Pampangan is so rich: 'En todas las lenguas significan estas los afectos del alma y son mas deffciles, si no imposibles de transuntar: explicarélas como pudiere' (198). Where he is unable to formulate rules, he resorts to listing and refers the reader to his Vocabulario: 'No hay mas remedio que examinar uno por uno, o ir al Vocabulario' (45). It is interesting to note that Bergaño had glimmerings of the notion of transformation. He remarks: '...ya la pasiva no muda el sentido de la activa' (148). Moreover, he connects sentences by stating that one sentence 'nace de', 'sale de' from another sentence.

### 5.3.2. Castrillo

Castrillo's M.A. thesis, based on Pittman's (1948) formulae for nuclear structures, is basically a taxonomy of surface structure types: 'This language study attempts to show the possible sentence constructions in the Pampango language' (1955:1). The types surveyed are: active (non-actor), passive (action-goal), equational (identification, description), conjunction, subordination, and other minor types. Following Lopez (1941), Castrillo describes three types of noun phrases: noun phrases in conjunctive attribution ( $i\eta$  marimlá+ $\eta$  gátas 'the cold milk'), noun phrases in disjunctive attribution ( $i\eta$  balé na $\eta$  Pédrú 'the house of Pedro'), and locative attribution (ka $\eta$  Pédrú 'to Pedro'). Expansions of V are considered (through addition of accompanying N's) as well as expansions of N (through relative clauses).

The work was completed in the heyday of American structuralist theory (the standard sources are listed in the bibliography) and uses an item-and-arrangement model (instead of a process model) in its listing of the various forms for pronouns; because of this, the treatment of the pronouns, especially of the so-called portmanteau pronouns (the term is from Hockett 1947), combinations of N copiers, is unsatisfactory. The list

of forms can easily be reduced and valid insights into the semantics of the pronouns easily discovered had a process model been adopted.

Castrillo analyses *ku* in

(5.3.2.1) *sinúlat ku... 'I wrote it...'*

as a portmanteau pronoun and glosses *ku* as '*I-it*'. Actually, a phrase such as the above would not occur by itself:

(5.3.2.1a) *sinúlat ku # in sinábi mu*  
*'What you said was written by me.'*

In this sentence, the subject is abstract and is not copied. Hence, there is no copier or pronoun for the subject in *V* and *ku* (as well as the sub-set of pronouns which are -SUBJECT and -OBLIQUE) is not a portmanteau pronoun but a simple pronoun.

Moreover, the postulation of only two voices (active and passive) is inadequate, considering the different possibilities for subjectivisation: there are as many voices as there are *N* relations discovered in the language.

The formulas for the different construction types, formulas consisting of concatenated morpheme classes, use pronouns where *N*'s would normally occur. Undoubtedly, this is due to the fact that in Pampangan, many *N*'s are deletable whereas their copiers (incorporated in *V*) are never deleted. Hence, where one is considering only surface structures, pronouns occur more regularly than noun roots. Semantically, however, this is unfortunate, since pronouns are clearly derivatives of *N* roots.

### 5.3.3. Lopez

Lopez (1965) surveys twelve Philippine languages (among them, Pampangan) and groups them according to their surface features. The criteria for grouping are: whether a particular surface unit exists in a language; among those languages which have the particular surface unit, whether its symbolisation is cognate with a corresponding surface unit in another language, or not. While the study is interesting from the point of view of comparative syntax and the grammatical typology on the Philippine languages, the study contains little that is useful for the purposes of this study. Two types of structures are examined, structures of predication and structures of attribution.

Among the structures of predication, Lopez (1965:6) speaks of 'circumlocutory definite object predication' and cites:

(5.3.3.1) *ing anak ya pin ing mi:turan ning bola*  
*'The child was (the one) hit by the ball.'*

(The citation is given in Lopez's transcription.) In my dialect, *kin bóla*, instead of *ning bóla*, would be used. Without syncopation, the sentence would be (in my transcription):

- (5.3.3.1') iη anák # iyá pin # iη mftúran kiη bóla  
<sup>x</sup>'The child he indeed the [one who] was hit by the ball.'=  
 'As for the child, the one who was hit by the ball  
 was he indeed.'

The above sentence would arise in the following situation. Someone asks a question: 'Who was hit by the ball?'

- (5.3.3.2) nfnu # iη mftúran kiη bóla  
 'The [one who] was hit by the ball is who?' =  
 'Who was hit by the ball?'

to which the answer would be:

- (5.3.3.2a) iyá # iη mftúran kiη bóla  
 'The [one who] was hit by the ball is he.'

where the context makes the lexical specification of iyá unnecessary. If the lexical root is specified, one would have:

- (5.3.3.2b) iη anák # iη mftúran kiη bóla  
 'The [one who] was hit by the ball is the child.'

In structures such as the above where the predicate noun is a subjectivised N, no subject copying process occurs; hence, there is no ya in the predicate. Now, another speaker, on hearing the response, may agree with the responder ('concurative') and say:

- (5.3.3.2c) iη anák pin iη mftúran kiη bóla  
 'Yes, indeed, the [one who] was hit by the ball  
 is the child.'

It seems that in the above sentence, one may additionally specify the predicate noun as TOPIC, in which case it seems that it is the predicate noun which is copied and not the subject:

- (5.3.3.2d) iη anák # iyá pin # iη mftúran kiη bóla  
 'As for the child, the [one who] was hit  
 by the ball is he indeed.'

The preceding 'derivational history' is tentative; the sentence could probably be derived by a different order. In any case, it is highly marked and occurs quite infrequently. It is not clear why Lopez chose to single out constructions of this type as a special basis for grouping the Philippine languages.

Three types of (surface) N/V relations are posited: conjunctive (malagú+η dalága 'pretty young woman'), disjunctive (balé niη dalága 'house of the young woman'), locative (\_\_\_ kiη anák 'to the child'). Under 'locative' are included 'time', 'place', 'possession'. Serial relation of N's is signalled by at (and ampó). It is not clear why

Lopez calls the negative specification of V a relation of 'absolute attributive': *é marók* 'not bad'.

Among the command sentences, Lopez lists Pampangan:

(5.3.3.3) *mekéni*

'Come in!' (2nd person sing. familiar)

and remarks: 'In...Pm. S [Subject] is  $\emptyset$  in the 2nd pers. sing.' (1965:13). The remark shows the inadequacies of an item-and-arrangement model. The underlying form of the command is:

(5.3.3.3') \**umé ka # kéni*

'You come to this place.'

The initial vowel undergoes apheresis; by haplology, *ka ke-* becomes *ka*. The subject pronoun is thus *ka* 'you', it is not  $\emptyset$ .

Lopez's study, it has been remarked, is based on a taxonomic survey of surface features. Its model is Bloomfield (1917:3): 'Bloomfield's chapter on 'Syntax' serves as a model, for to this writer his *Tagalog Texts with Grammatical Analysis...* as a treatise on any single Philippine language, remains unmatched'. From the point of view of typology, the study of surface features is still valid, since such surface features are the outputs of post-semantic processes (or transformations). It is precisely in this post-semantic area that language-specific features are most prominent. To examine therefore and to compare the results of such language-specific rules remains a worthwhile undertaking in grouping and typologising. In the last section, I shall return to this point and relate a work such as Lopez's to the question of semantic analysis, comparative grammar, and diachronic linguistics.

#### 5.3.4. Constantino

In terms of its theoretical import, Constantino's (1965) study of 'The Sentence Patterns of Twenty-Six Philippine Languages' remains the most significant from the point of view of modern linguistics.

Essentially, the article, which appeared in *Lingua*, is a report of research in progress, since Constantino's aim is an ambitious one: '...this is an attempt to construct a single grammar in generative transformational form of the twenty-six Philippine languages [surveyed]' (1965:109).

The model for analysis is based on Chomsky (1957). Phrase-structure rules are formulated to generate 'kernel' sentences, 'from which we derive the other sentences by means of transformational rules' (1957:77).

The set of base-structure rules is common to the twenty-six languages; where special rules have to be formulated for particular languages,

such rules are formulated at the end of the section on base-structure rules. One such rule (Rule 25) is formulated for Pampangan, essentially a symbolisation rule for determiners in a subject N. The second set of rules consists of transformational rules, many of which are shared by several languages; where a transformational rule applies to only one language, then that rule is language-specific. Five such specific rules are formulated for Pampangan (Rules 10, 15, 16, 19, 20); for the most part, these rules generate what I have called in this study 'incorporation processes', copying features of N into V. Constantino labels such copying as 'addition'; where no copying takes place or where copiers are deleted, the process in Constantino's rules is a 'deletion' process. For the purposes of this study, only Constantino's rules concerning Pampangan are relevant.

Constantino's concept of a 'kernel sentence' is problematic (apart from the problems engendered by revisions in the theory of transformational generative grammar). He takes 'the definite sentence' as the 'kernel' and the input to his transformations. Such a definite sentence is exemplified by the following (1965:80):

Kap.:                    / qɪŋ qanak qɪŋ milayi . /  
                               *the child the ran-away*  
                               '*It was the child who ran away.*'

(The citation is given in Constantino's transcription. /q/ is a glottal stop; in my notation, glottal stop is stated to be optional in initial position and not noted in the transcription. ./ signals falling intonation.) The phrase-structure (immediate constituent) analysis is:

IC 1	IC 2
SUBJECT	PREDICATE
qɪŋ qanak	qɪŋ milayi
<i>the child</i>	<i>the ran-away</i>

Constantino's gloss is accurate: '*It was the child who ran away*', more literally, '*The [one who] ran away [was] the child*'. It is the analysis which is problematic. First of all, the sentence is clearly an equational sentence where *ɪŋ anák* '*the child*' is not the subject but the predicate (a predicate noun) and where *ɪŋ mɪlayɪ* '*the [one who] ran away*' is the subject (an N with an attached relative clause). The semantic structure would be:

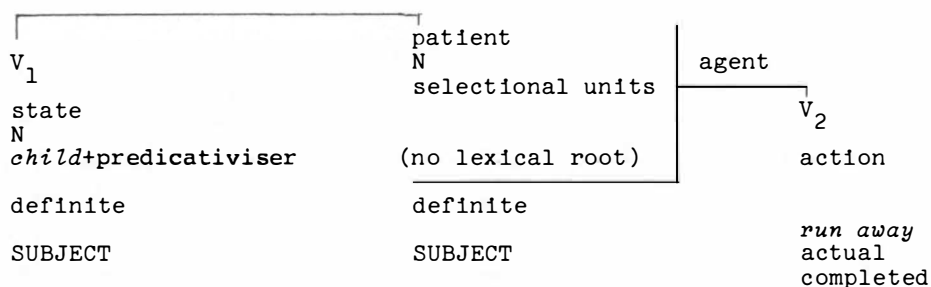

The sentence is highly marked and occurs only as a response to a question:

nɪnu # iŋ mɪlayɪ?  
'The [one who] ran away is who.' =  
'Who ran away?'

to which the response could be:

iŋ anák (# iŋ mɪlayɪ?)  
'(The one who ran away is) the child.'

There is thus a radical disagreement between the semantic configuration I propose and Constantino's IC-analysis, for his subject is my predicate (a predicate noun) and his predicate (a verbal one) is my subject (an N with an attached relative clause).

In a footnote, Constantino (1965:77) mentions Bloomfield: 'Bloomfield...analyzes IC<sub>1</sub> always as predicate and IC<sub>2</sub> always as subject. We have not followed this analysis in every respect'. Actually, it seems to me that Bloomfield's unerring linguistic good sense should have been followed once more on this point.

In any case, Constantino postulates a PM (Predicate Marker) for verbal definite sentences (such as the one cited): 'The predicate of a definite sentence consists of a verb or verb phrase, an adjective, a common noun, or a particulate phrase, preceded by a predicate marker'. Since Constantino's citations all include the predicate marked by qɪŋ, I can only conclude that he intended qɪŋ to be PM, although he glosses qɪŋ rightly as 'the'. On the basis of what I have established in the preceding chapters, qɪŋ is clearly a subject determiner and not a predicate marker homophonous with subject determiner qɪŋ in Constantino's IC<sub>1</sub>.

With the 'definite sentence' as kernel, Rule 14 is postulated, transforming a 'definite sentence' into an 'indefinite sentence' by what amounts to a simple process of deletion (1965:116):

INPUT / qin qanak qin milayi. /  
 OUTPUT / qanak ya qin milayi. /

ya is considered an addition of a nominative pronoun and is not relevant at this point. Semantically, the difference is manifest by Constantino's own glosses. I fail to see, however, what justification there is for transforming a sentence which refers to a definite child to a sentence which refers to any child. Formally, of course, the transformation process is a simple instance of formative deletion. However, what constrains the theory of transformational generative grammar from postulating the most fanciful transformations (from one phrase marker to another phrase marker) is precisely the postulate, made explicit by Katz and Postal (1964), that meaning is preserved through the transformational cycle and that no new semantic content is added by transformations (qualifications to this postulate have been proposed lately by Chomsky 1969). But where two sentences are semantically distinct, no matter how closely they resemble each other in their surface structures and in their lexemes, one cannot state that one sentence is transformed into another sentence.

With the above 'transformation', Constantino discusses various types of 'indefinite sentences' (where the IC<sub>1</sub>, Constantino's subject, no longer has the article qin): 'An adjective may occur as the subject of the goal or locative passive sentence, in which case it will not be preceded by any marker' (1965:87). He cites a Tagalog example (number 57) for which I shall give the Pampangan equivalent:

márayú? # in linákad na nin anák  
 'What was walked by the child is far.'

Constantino's citation is:

Tag. / mala'yo qan nilakad nan bataq. /  
 far the walked PAM-child  
 the  
 'The child walked far away.'

where PAM is 'Passive Actor Marker' (/ / is a marker for vowel length). The gloss is inexact. The subject of the sentence is the whole clause in linákad na nin anák 'that which was walked by the child/ (the) what was walked by the child', of which is predicated the state V 'far'.

A third transformation using the 'definite sentence' as kernel is postulated, the output of which is a 'situational sentence' (in this study, a sentence with a non-state V). Rule 17, the Rule on Situational Sentences, would derive the following (1965:119):

INPUT / qıŋ qanak qıŋ milayi. /  
*the child the ran-away*

OUTPUT / milayi ya qıŋ anak. /  
*ran- he the child*  
*away*  
*'It was the child who ran away.'*  
*'The child ran away.'*

The derivation of the output from the input, from a purely formal viewpoint, is quite simple (precluding considerations of *ya*): transposition of *qıŋ qanak* to the end of the sentence, deletion of *qıŋ* preceding *milayi*. Semantically, however, the two sentences are quite distinct. The first sentence is an equational sentence, usually an answer to the question, '*Who ran away?*' The second sentence is a simple statement, '*The child ran away*'.

The implausible transformations proposed demonstrate quite clearly, if nothing else, the function of semantics in grammar (even if one does not accept Chafe's position that syntax is actually not distinct from but part of semantics): what motivates the transformational generative grammarian to postulate sentential connections is identity of semantic import. There is nothing in the theory of formal language itself (more especially, in the theory of the characterisation of the transformational component) to prevent one phrase marker from being transformed into a totally different phrase marker; in other words, transformational rules can be made as powerful as warranted. The constraint, as far as natural languages are concerned, seems to me to be semantic: only such transformations which preserve semantic identity can be posited. In grammatical analysis, then, semantic considerations are primary. One must not be led by surface similarities in structure and in lexical choice as well as symbolisation to posit transformations where such transformations are semantically implausible.

Surely, to derive ordinary non-state V sentences from an equational sentence seems implausible, considering that one goes from a highly marked equational sentence to the least marked (and most frequent) type of  $\overline{V}$  N structure. Such considerations must outweigh any aesthetic considerations that perfectly balanced IC's in equational sentences present.

A close comparison between the description of various data in this study and Constantino's analysis will show further points of disagreement of lesser importance. They will be stated only summarily.

(1) Constantino (1965:76) equates tense and aspect: 'Note that the verbal affix has three components: voice, mode and tense or aspect'.

He formulates a rule:

$$TM \quad \rightarrow \quad TA + MD \quad (MA)$$

where TM = Tense Marker, TA = Tense/Aspect, MD = Mode, MA = Ability. The derivational rules given in Chapter I show quite clearly that *abilitatitiser* (in Pampangan, symbolised by *maka-*) is only one among many other possible derivational units; since it is a lexical (derivational) unit, it should be analysed separately from inflectional units (tense/aspect and mode). Tense, it was shown in Chapter III, is best considered a selectional unit of a temporal state V; in turn, the temporal state V is predicated of an embedded  $\overline{V}$  N configuration. Post-semantically, tense units may be incorporated as inflectional units into a subordinate or embedded V. Moreover, tense dictates aspectual specification in a subordinate V; aspectual specifications are inflectional units of V. Traditional mode (indicative, imperative, optative) was analysed in terms of illocutionary verbs; where overtly marked, such markers would be incorporated into semantic V as inflectional units and eventually linearised and symbolised as unbound particles, not affixes.

(2) Constantino places great emphasis on the active/passive dichotomy. Thus, all verbal sentences (in this study, Constantino's verbal sentences would be analysed as equational sentences in which the subject N has an attached relative clause, the V of which is an action or a process-action V) in which the agent N of the relative clause is -SUBJECT and -OBLIQUE are labelled 'passive'. Hence, different types of passives are posited: goal (= patient), locative, benefactive, instrumental, reciprocal (e.g., the interlocutor in a conversation, hence, either a goal or an associate N), agentive (in this study, motivative). To be perfectly consistent, if one adopts the active/passive dichotomy as primary, then one should add to the above list of passives the following: complementive, mensurative, materiative, normative, associative, partitive, abessive (source), adessive (goal), temporal, experiential. Because of these different N relations, the two -SUBJECT determiners, *naŋ/niŋ* and *kan/kiŋ*, are labelled by Constantino as homophonous formatives of different markers: CM (Complement Marker), IGM (Indefinite Goal Marker), DGM (Definite Goal Marker), LM (Locative Marker), BM (Benefactive Marker), IM (Instrumental Marker), RAM (Reciprocal Agentive Marker), AM (Agentive Marker). In this analysis, such relations were postulated as obtaining in semantic structure but post-semantically marked as either OBLIQUE or -OBLIQUE.

(3) Constantino formulates rules for 'addition of nominative pronoun' (ya) and 'addition of passive agentive pronoun' (na) and notes (1965:95): 'If the noun is an inanimate noun, the addition of the pronoun is optional'. In Chapter II it was shown that not only is a non-subject and non-oblique agent N copied but likewise a non-subject and non-oblique patient N in a process V. Moreover, it is not the selectional specification '-animate' which blocks subject copying but the specifications 'abstract' or '-count'. Finally, in equational sentences where the predicate noun is subjectivised, the subject N is not copied either.

(4) Constantino formulates two rules for 'addition of nominative pronoun', Rules 15 and 19, corresponding to the incorporation processes I have described. Thus:

INPUT / milayi qiq qanak. /  
 OUTPUT / milayi ya qiq qanak. /  
           '*The child ran away.*'

where ya copies '*the child*'; this rule is formulated as Rule 19. As an example of Rule 15, the following is cited:

INPUT / qanak qiq me'nan kiq manga. /  
 OUTPUT / qanak ya qiq me'nan kiq manga. /  
           '*It was a child who ate the mango.*'

Constantino states that ya in this case does not refer to the qiq phrase (which in this case Constantino considers as the predicate) but to the 'indefinite subject' qanak. Hence, the necessity for formulating a separate rule, Rule 15, since, according to Constantino, what is copied is the initial formative. My analysis, however, has shown that in this instance, ya still copies the qiq phrase provided one considers qanak not as the subject but as the predicate, a -definite (and -SUBJECT) predicate noun. There is therefore no need to postulate two rules for the addition of nominative pronoun' (see 1965:117 and 119).

(5) Constantino (1965:117-8) proposes the following derivation:

- (a) / qiq qanak qiq me'nan kiq manga. /  
       '*It was the child who ate the mango.*'
- (b) / qiq manga qiq pe'na' niq qanak. /  
       '*It was the mango which was eaten by the child.*'
- (c) / qiq manga qiq pe'na' na niq qanak. /  
       '*It was the mango which was eaten by the child.*'

- (d) /       manga qiq pe'na' na niq qanak. /  
           '*It was a mango that was eaten by the child.*'
- (e) /       manga ya qiq pe'na' na niq qanak. /  
           '*It was a mango which was eaten by the child.*'
- (f) /       manga qiq pe'na' na niq qanak. /  
           '*It was a mango which was eaten by the child.*'

The sequence (a) to (b) to (c) is an example of the passive transformation, the choice of patient N instead of agent N as subject. It is with the sequence (c) to (d), from definite to indefinite, that an objection may be raised, the objection already raised concerning constraints on transformations. Moreover, I fail to see the usefulness of the (d) to (f) sequence, since the output of (d) is identical with the output of (f). In other words, the copier *ya* was introduced transformationally and then deleted. Actually, the transformation postulated between (d) and (e) is dubious, since literally (d) means

*'What was eaten by the child was a mango.'*  
*'What was eaten by the child were mangoes.'*

where the predicate noun is -definite. On the other hand, (e) means:

*'What was eaten by the child was the mango.'*

where the predicate noun is definite. Once again, the semantic import of the two sentences is different; it is dubious therefore that (e) is derived from (d). The same objection may be raised to the postulation of a transformation from (e) to (f) since the definite to indefinite switch is once more questionable.

(7) Constantino analyses the phrase

keq           qanak  
 LM-DM-*the child*

where LM is Locative Marker, DM is Definite Marker; he differentiates it from

kiq           qanak  
 LM- *-the child*

(see 1965:46). Rather than differentiate *kiq* from *keq* by the semantic unit 'definite', the differentiating unit is 'demonstrative: proximate to speaker'. Hence, *keq qanak* means '*to that child near you*'. Both *kiq* and *keq* are 'definite'.

(8) 'A particle (PRT) occurs between the possessive article, affirmative or negative, and the common noun...' (1965:91). The example given is:



symbolisations these take in combination with other affixes. The bilingual dictionary will take different forms according to its purposes. A pedagogical bilingual dictionary, for example, would do well to list rules such as

(Sy)	root+(derivational unit)	→	PREFIX+INFIX+
	repetitive / plural		ROOT+SUFFIX
	rel subject		

since in actual language use, one normally uses whole combinations rather than individual units. The different symbolisations of the incorporated subject markers likewise demand separate treatment.

Chafe's semantic model demands a lexicon different from a dictionary. The lexicon will consist of a list of specification rules whereby matrices of selectional units eventually narrow lexical choice down to a definite unit, based on previous specifications. Hence:

(LEXICAL RULE)	V/N	
	selectional unit x	
	selectional unit y	
	selectional unit z	→→ root+(derivational unit)

The dictionary on the other hand, will consist of a list of replacement rules whereby lexical units or matrices of selectional and inflectional units (mostly the latter) are directly symbolised by phonological sequences. Prior to symbolisation, the deletion processes will have applied. Hence:

(SYMBOLISATION RULE)		
	root	→ AAA
	derivational unit	→ BBB
	[ (selectional unit) inflectional unit(s) ]	→ CCC

The tense-aspect relations between temporal state V and non-state V have to be formulated through aspectual harmony rules and through tense governance rules for aspect.

The area of pre-semantic structure necessitates more elaborate and formal treatment; it seems, too, that this field of research will yield very important insights into semantic universals as well as the general theory of communication.

Ultimately, of course, semantic considerations in language will lead into discourse analysis which, except for the work of Harris (1952), whose concept of semantic structure is totally different from the type of semantic structure pre-supposed in this study, and the initial work of the tagmemists, notably, of Pike and Longacre (see Pike 1966

for a list of available published material), has been studiously avoided by linguists, leaving the field to rhetoricians, few of whom have the adequate conceptual tools and formalism necessary for this type of inquiry. The area of discourse analysis invites the linguist to new endeavours for which at present he does have the necessary tools for analysis; it is an area which he can ill neglect, since so many of the facts of language will prove recalcitrant to adequate formulation as long as he confines himself to the nuclear sentence.

Finally, the study of the semantic structures and post-semantic processes of Pampangan (and of the other Philippine languages) will yield data for linguistic typology, so necessary in comparative work, as well as for more satisfactory groupings based on grammatical criteria (on the content side of language) to complement phonological criteria (on the expression side of language). While this study in many details disagrees with Constantino's formulations, Constantino's own objective, to write a common grammar for the Philippine languages, remains a valid and feasible undertaking, since the Philippine languages are similar enough at this stage of their evolution to permit such a common grammar. On the basis of shared innovations comparable to the work of Lopez, formulated in terms not of mere surface features, however, but in terms of post-semantic processes (or transformations), perhaps insight into the states of diversification that these languages have undergone can be gained and clues about the history of these languages attained, thus contributing to the progress of diachronic linguistics.

## BIBLIOGRAPHY

### PRE-TWENTIETH CENTURY

#### ALAFON(T), Mariano

n.d. Notas y adiciones al arte pampango del padre Vergaño. MS  
(18th  
century)

#### BARRANTES Y MORENO, Vicente

1889 'Linguística Filipina'. *El Teatro Tagalo* 3:167-96.  
Madrid: M.G. Hernández.

#### BENAVENTE, Álvaro de

n.d. Arte y diccionario pampango. MS.  
(18th  
century)

#### BERGAÑO, Diego

1729 *Arte de la lengua pampanga*. Manila: Sebastián López.

1732 *Bocabulario de pampango en romance, y diccionario de romance en pampango*. Manila.

1736 *Arte de la lengua pampanga*. (Second edition). Manila.

1860 *Vocabulario de la lengua pampanga en romance*. (Reimpreso/  
Reprinted.) Manila: Ramírez y Giraudier.

#### BLUMENTRITT, Ferdinand

1882, *Vocabular eizelner Aüsdrucke und Redensarten, welche dem*  
1885 *Spanischen der Philippinischen Inseln eigenthümlich sind.*  
*Mit einem Anhang: Bibliotheca Philippina. (Parts I and II).*  
Leitmeritz: Karl Pickert.

## BRABO (BRAVO), Antonio

- 1875 *Vade mecum filipino ó manual de la conversación español pampango.* (1<sup>a</sup> edición.) Manila: Imprenta de Ramírez y Giraudier.
- 1886a *Cuestiones gramaticales: sus contestaciones.* Candaba (dated August 10, 1886).
- 1886b *Yslas Filipinas. Cuestionario y vocabulario de la lengua pampanga dialecto...recogidas por el Sr. Fr. Antonio Bravo en el pueblo de Candaba el día 10 de agosto 1886.*

## CALLEJA, J.

- ca.1765 *Clave para escribir y leer en pampango.* MS.

## CORONEL, Francisco

- 1617 *Reglas para aprender el idioma pampango.* Manila [?].
- 1621 *Arte y reglas de la lengua pampanga.* MS. (Eduardo Navaro [sic ?] Collection, Valladolid).
- 1875 *Catecismo Pampango Arte y vocabulario del mismo idioma.* (Reimpresion/Reprinted.) Manila.

## FORONDA, S.

- ca.1710 *Vocabulario pampango.* MS. Candaba.

## FORSTER, Johann Reinhold

- 1778 *Observations faites, pendant le second voyage de M. Cook, dans l'hémisphère austral: vol. 5 of James Cook. Voyage dans l'hémisphère austral.* Paris: Hôtel de Thou.

## KERN, Hendrick

- 1890 *'Sprachvergleichende Bemerkungen zum vorhergehenden Verzeichnisse [Meyer's Vocabular der Negritosprache]'*. In: A.B. Meyer and H. Kern, vol.2:49-67. Dresden: Stengel and Markert.

## LACOUPERIE, A.E. Terrien de

- 1887 *Formosa Notes on manuscripts, languages, and races.* Hertford: (No publisher indicated).

## MASNOU, G.

- 1875 Capabaluan ampon usuc é matampa caring tabasna t linica etc. capampangan ning P. Fr. G. Masnou, Manila.

## MEYER, Adolph Bernhard

- 1878 *Über die Negritos oder Aetas der Philippinen.* Dresden.

## MORENO, Sebastián

- n.d. Sobre el modo de comprender el idioma pampango y su  
(16th century) poesia. 2 vols. MS.

## OCHOA, Diego

- ca.1580 Arte, vocabulario y confesionario pampango. MS. Lubao.

## PALLAS, P.S.

- 1787-89 *Vocabularium Catharinae.* (2 vols.) St. Petersburg.

## TWENTIETH CENTURY

## ALEXANDER, William

- 1968 *A Short Synopsis of the Most Essential Points in Hawaiian Grammar.* Tokyo: Charles E. Tuttle. (Reprinted.)

## ANANTHANARAYANA, H.S.

- 1969 The Karaka Theory and Case Grammars. Proceedings of the 25th Session of the All-India Oriental Conference. Jadavpur University, Calcutta. Mimeograph.

## ANDERSON, Tommy Ray

- 1965 A Contrastive Analysis of Cebuano Visayan and English. Doctoral dissertation, UCLA.

## AUSTIN, John L

- 1962 *How to do Things with Words.* Oxford: Clarendon Press.

## AUSTIN, Virginia M.

- 1966 Attention, Emphasis, and Focus in Ata Manobo. M.A.thesis, Hartford Seminary Foundation, Hartford, Connecticut.

## BERGAÑO, Diego

- 1916 *Arte de la lengua pampanga.* Tercera Edición. Manila: Tip. del Colegio de Santo Tomás.

## BLAKE, Frank Ringgold

- 1906 'Contributions to Comparative Philippine Grammar'. *Journal of the American Oriental Society* 27:317-96.
- 1907 'Contributions to Comparative Philippine Grammar: Numbers'. *Journal of the American Oriental Society* 28:199-253.
- 1908 'The Tagalog Ligature and Analogies in Other Languages'. *Journal of the American Oriental Society* 28:199-253.
- 1910 'Expression of the Ideas "to be" and "to have" in the Philippine Languages'. *Journal of the American Oriental Society* 30:375-91.
- 1916 'Construction of coordinated Words in the Philippine Languages'. *American Journal of Philology* 37:466-74.
- 1920 'A Bibliography of the Philippine Languages'. *Journal of the American Oriental Society* 40:25-70.

## BLOOMFIELD, Leonard

- 1917 *Tagalog Texts with Grammatical Analysis*. University of Illinois Studies in Language and Literature, 3/2-4. Urbana: University of Illinois.

## BOLINGER, Dwight

- 1965 'The Atomization of Meaning'. *Language* 41:555-73.

## BOWEN, J. Donald, and others, eds

- 1965 *Beginning Tagalog: a Course for Speakers of English*. Berkeley: University of California Press.

## BRANDSTETTER, Renward

- 1916 *An Introduction to Indonesian Linguistics*. Translated by C.O. Blagden. London: Royal Asiatic Society Monograph 15.

## BÜHLER, Karl

- 1934 *Sprachtheorie*. Jena: Fischer.

## CASTRILLO, Maria Luisa Y.

- 1955 Pampango Syntax. M.A.thesis, University of the Philippines.

## CHAFE, Wallace C.

- 1962 'Phonetics, Semantics, and Language'. *Language* 38:335-44.
- 1965 'Meaning in Language'. In: E.A. Hammel, ed. *Formal Semantic Analysis*, 23-36. *American Anthropologist* 67/5(2).
- 1967 'Language as Symbolization'. *Language* 43:57-91.
- 1968 'Idiomatcity as an Anomaly in the Chomskyan Paradigm'. *Foundations of Language* 4:109-27.
- 1970a *A Semantically Based Sketch of Onondaga*. *IJAL Memoir* 25.
- 1970b *Meaning and the Structure of Language*. Chicago: University of Chicago Press.
- 1971 'Directionality and Paraphrase'. *Language* 47:1-26.

## CHOMSKY, Noam

- 1957 *Syntactic Structures*. The Hague: Mouton.
- 1965 *Aspects of the Theory of Syntax*. Cambridge, Mass.: MIT Press.
- 1969 *Deep Structure, Surface Structure and Semantic Interpretation*. Indiana University Linguistics Club. Mimeograph.

## CHRÉTIEN, C. Douglas

- 1962 'A Classification of Twenty-one Philippine Languages'. *Philippine Journal of Science* 91:485-506.

## CLARDY, Catherine Jane

- 1958 *Pampango Phonology*. Doctoral dissertation, University of Texas.
- 1959 'Pampango Phonology'. *Phonetica* 3:118-44.

## CONANT, Carlos Everett

- 1907 "F" and "V" in Philippine Languages. Leipzig: M. Pöcke.
- 1909 'The Names of Philippine Languages'. *Anthropos* 4:1069-74.

- 1910 'The RGH Law of Philippine Languages'. *Journal of the American Oriental Society* 31:70-85.
- 1911 'Monosyllabic Roots in Pampango'. *Journal of the American Oriental Society* 31:389-94.
- 1912 'The Pepet Law in Philippine Languages'. *Anthropos* 7: 920-47.
- 1916-17 'Indonesian l in Philippine Languages'. *Journal of the American Oriental Society* 36:181-96.

CONKLIN, Harold C.

- 1951 Lexical Check-list for Philippine Languages. Mimeograph. New Haven.
- 1952 Outline Gazetteer of Native Philippine Ethnic and Linguistic Groups. Mimeograph.

CONSTANTINO, Ernesto

- 1960 A Transformational Grammar of Ilocano. Doctoral dissertation, Indiana University.
- 1965 'The Sentence Patterns of Twenty-six Philippine Languages'. *Lingua* 15:71-124.

DEMPWOLFF, Otto

- 1924-25 'Die L-, R- and D-Laute in Austronesischen Sprachen'. *Zeitschrift für Eingeborenen-Sprachen* 15:19-50, 116-138, 223-238, 273-319.
- 1934, 1937, 1938 *Vergleichende Lautlehre des austronesischen Wortschatzes. Beihefte zur Zeitschrift für Eingeborenen-Sprachen* 15, 17, 19. Berlin.

DIMALANTA, Gavino, D.E. FERNÁNDEZ, and S.G. CALDERÓN

- n.d. *Vocabulario Pampango-Tagalog-Inglés*. Maynila: Imprenta, (20th century) Libreria y Papeleria ni J. Martinez.

DYEN, Isidore

- 1965 *A Lexicostatistical Classification of the Austronesian Languages*. Indiana University Publications in Anthropology and Linguistics, Memoir 19 of IJAL, 31/1.

## FERNÁNDEZ, D.

- 1901 *Nuevo vocabulario ó manual de conversaciones en español, tagalo y pampango*. 5<sup>a</sup> Edición. Binondo (Manila): Liberia Tagala. (Other Editions: First, 1876 Binondo; Second, 1882 Manila; Third, 1887 Manila [?]; Fourth, 1896 Manila).

## FILLMORE, Charles J.

- 1968 'The Case for Case'. In: Emmon Bach and Robert T. Harms, eds *Universals in Linguistic Theory*, 1-88. New York: Holt, Rinehart and Winston.

n.d. The Grammar of 'hitting' and 'breaking'. Mimeograph.

## FIRTH, J.R.

- 1957 'A Synopsis of Linguistic Theory, 1930-1955'. In: J.R. Firth, ed. *Studies in Linguistic Analysis*, 1-32. Oxford: Blackwell.

## FREGE, Gottlob

- 1952 'On Sense and Reference'. In: Peter T. Geach and Max Black, eds *Philosophic Writings*, 56-68. Oxford.

## GONZALEZ, Andrew

- 1969 On Reconstructing Common Philippine: Phonology and Basic Vocabulary. MS.

1970 'Acoustic Correlates of Accent, Rhythm, and Intonation in Tagalog'. *Phonetica* 22:11-44.

## GOODENOUGH, Ward H

- 1956 'Componential Analysis and the Study of Meaning'. *Language* 32:195-216.

## HALLIDAY, Michael A.K.

1961 'Categories of the Theory of Grammar'. *Word* 17:241-92.

1966 'Some Notes on "deep" grammar'. *Journal of Linguistics* 2:55-67.

## HARRIS, Z.S.

- 1952 'Discourse Analysis'. *Language* 28:1-30.

HOCKETT, Charles F.

1947 'Problems of Morphemic Analysis'. *Language* 23:321-43.

INSTITUTE OF NATIONAL LANGUAGE

1937-40 Preliminary Studies on the Lexicography of the Philippine Languages. *Publications of the Institute of National Language* 1:1-11. Manila.

n.d. The Principal Affixes Used in the Formation of Verbs - Tagalog and Pampango. MS.

n.d. The Principal Affixes Used in the Formation of Adjectives - Tagalog and Pampango. MS.

n.d. Homophonous Forms with Identical Meanings - Tagalog-Kapampangan. MS.

n.d. 1000 Basic Words Tagalog-Kampanpangan-English. MS.

n.d. 3000 Words - Kapampangan-Tagalog-English (based on Bergaño). MS.

KATZ, Jerrold J., and Paul M. POSTAL

1964 *An Integrated Theory of Linguistic Descriptions*. Cambridge, Mass.: MIT Press.

KIPARSKY, P., and J.F. STAAL

1969 'Syntactic and Semantic Relations in Pāṇini'. *Foundations of Language* 5:83-117.

KROEBER, Alfred L.

1919 *Peoples of the Philippines*. American Museum of Natural History Handbook 8. New York.

LAKOFF, George

1971 'On Generative Semantics'. In: Danny D. Steinberg and Leon A. Jakobovits, eds *Semantics An Interdisciplinary Reader in Philosophy, Linguistics, Anthropology and Psychology*, 232-296. London: Cambridge University Press.

LAKOFF, Robin

1969 *Abstract Syntax and Latin Complementation*. Cambridge, Mass.: MIT Press.

LEES, Robert B.

- 1960 *The Grammar of English Nominalizations*. Indiana University Research Center in Anthropology, Folklore, and Linguistics, Publication 12 (IJAL 26/3 (2)). Bloomington, Indiana.

LEWIS, M.B.

- 1965 *Teach Yourself Malay*. London: The English Universities Press.

LIEBERMAN, Philip

- 1967 *Intonation, Perception, and Language*. Cambridge, Mass.: MIT Press.

LLAMZON, Teodoro

- 1966 'Tagalog Phonology'. *Anthropological Linguistics* 8/1:30-9.

LOPEZ, Cecilio

- 1941 *A Manual of the Philippine National Language*. Third Edition. Manila: Bureau of Printing.

- 1965 'Contributions to a Comparative Philippine Syntax'. *Lingua* 15:3-16.

MAGAT, G.

- 1915 *Gramatica qng saving castila, t capampangan*. Manila.

MANALILI, Bienvenido M. and J.P. TAMAYO

- 1964 *English-Tagalog Pampango Vocabulary*. Quezon City: Pressman.

MCCAWLEY, James D.

- 1968a 'The Role of Semantics in a Grammar'. In: Emmon Bach and Robert T. Harms, eds *Universals in Linguistic Theory*, 124-69. New York: Holt, Rinehart and Winston.

- 1968b 'Lexical Insertion in a Transformational Grammar without Deep Structure'. *Papers from the Fourth Regional Meeting of the Chicago Linguistic Society*, 71-80.

MCKAUGHAN, Howard

- 1962 'Overt Relation Markers in Maranao'. *Language* 38:47-51.

MENDOZA, Virginia Gamboa

- 1940 *Phonological* of Pampangan. Publications of the Institute of National Language, Bulletin 4. Manila.

MORGAN, Jerry L.

- 1969 'On the Treatment of Presupposition in Transformationalist Grammar'. *Papers from the Fifth Regional Meeting of the Chicago Linguistic Society* 167-77.

OTANES, Fe Torres

- 1966 A Contrastive Analysis of English and Tagalog Verb Complementation. Doctoral dissertation, UCLA.

PARDO de TAVERA, Trinidad H.

- 1903 *Biblioteca filipina ó sea catálogo razonado de todos los impresos, tanto insulares como extranjeros*. Washington, D.C.: Government Printing Office.

PARKER, Luther

- 1905 *An English-Spanish-Pampango Dictionary*. Manila.

PEREZ, Alejandrino

- 1964 Pampango and Tagalog Cognates: Sound and Spelling Relationships. M.A. thesis, Philippine Normal College, Manila.

PHELAN, John Leddy

- 1955 'Philippine Linguistics and Spanish Missionaries, 1565-1700'. *Mid-America* 37:153-70.

PHILIPPINES, REPUBLIC OF THE: BUREAU OF THE CENSUS AND STATISTICS

- 1960 Census of the Philippines: Population and Housing Summary Report, Department of Commerce and Industry.

PIKE, Kenneth L.

- 1963 'A Syntactic Paradigm'. *Language* 39:216-30.
- 1966 'A Guide to Publications Related to Tagmemic Theory'. In: Thomas A. Sebeok, ed. *Current Trends in Linguistics*, vol.3, 365-94. The Hague: Mouton.

PITTMAN, Richard Saunders

- 1948 'Nuclear Structures in Linguistics'. *Language* 24:287-92.

ROBINS, R.H.

- 1967 *A Short History of Linguistics*. Bloomington: Indiana University Press.

ROOD, David Stanley

- 1970 *Wichita Grammar - A Generative Semantic Sketch*. Doctoral dissertation, UC, Berkeley.

ROSS, John Robert

- 1970 'On Declarative Sentences'. In: Roderick A. Jacobs and Peter S. Rosenbaum, eds *Readings in English Transformational Grammar*, 222-72. Waltham, Mass.: Ginn.

SADOCK, Jerrold M.

- 1969a 'Super-hypersentences'. *Florida State University Papers in Linguistics* 1/1:1-15.

- 1969b 'Hypersentences'. *Florida State University Papers in Linguistics* 1/2:283-370.

SAPIR, Edward

- 1921 *Language*. New York: Harcourt, Brace and World.

SCHACTER, Paul and Fe T. OTANES

- 1972 *Tagalog Reference Grammar*. Los Angeles: UC Press.

SEARLE, John R.

- 1969 *Speech Acts*. Cambridge University Press.

SHETLER, J. and others

- 1966 *Papers in Philippine Linguistics, No.1, PL, A-8*.

TABASONDRA, Iluminada S.

- 1962 'Pampango Consonants and Vowels and their Influence on English Spoken by Pampangos in Tarlac'. *Philippine Journal for Language Teaching* 1/3-4:1-6.

THOMAS, David and Alan HEALEY

- 1962 'Some Philippine Language Sub-Groupings: A Lexico-statistical Study'. *Anthropological Linguistics* 4/9:21-33.

THOMPSON, Richard N.

- 1953 *Survey Study of the Languages of the Philippine Islands*.  
Pampanga: Community Press.

VERSTRAELEN, Eugene

- 1962 'Soundshifts in Some Dialects of the Philippines'.  
*Anthropos* 57:826-56.

VIRAY, Felizberto B.

- 1941 'Prenasalization in the Philippine Languages'. *Philippine  
Social Science Review* 13:119-47.

VOEGELIN, C.F. and F.M. VOEGELIN

- 1965 *Languages of the World: Indo-Pacific Fascicle Four*.  
*Anthropological Linguistics* 7/2.

WANG, William S.-Y.

- 1968 The Many Uses of Fo. Project on Linguistic Analysis Reports,  
2nd Series, Number 8, December, W1-W35. Berkeley.

WELSH, Doris Varner, compiler

- 1950 *Checklist of Philippine Linguistics in the Newberry Library*.  
Chicago: The Newberry Library.

WOLFENDEN, Elmer et al.

- 1964 'Papers on Philippine Linguistics, by members of the  
Summer Institute of Linguistics'. *Oceanic Linguistics*  
3/1:1-199.

ZIMMER, Karl E.

- 1964 *Affixal Negation in English and Other Languages: An  
Investigation of Restricted Productivity*. Supplement  
to *Word* 20/2: Monograph 5.