

NOTE: REASON FOR "POLISH" & "BREAK EDGES" IS TO AVOID SNAGGING OR CUTTING 0.060 φ WIRE USED FOR WINDING

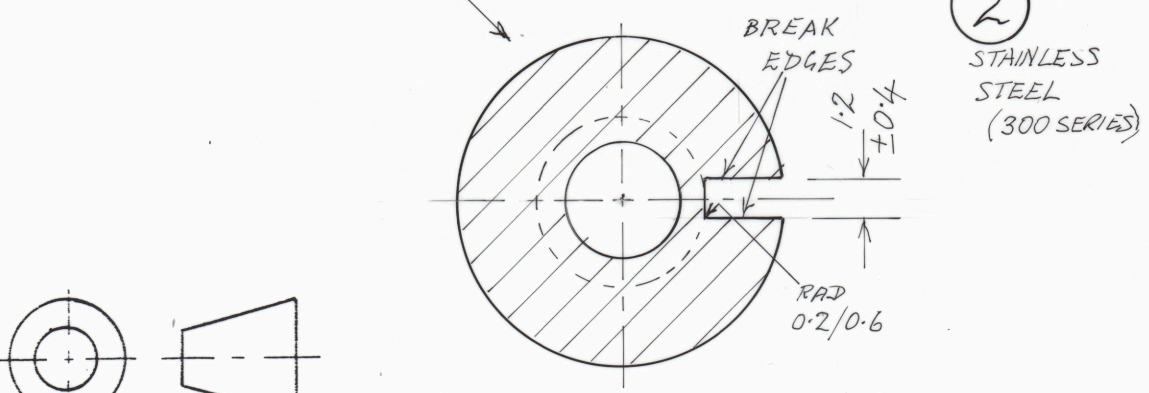

DIMENSIONS IN MILLIMETERS - DO NOT SCALE		PATERSON HPT TESTING MACHINE	
		FORMER FOR AXIAL DISPLACEMENT LVDT'S	
A3	SCALE 5:1	DATE AUG 03	DRAWING NO 4506B