

LEMO ELBOW PLUG
FHG 2B 308
DRILLED AXIALLY $\phi 3.2$

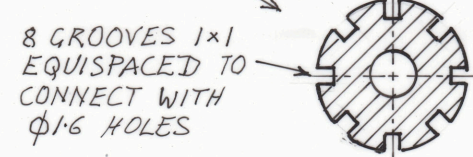

1 ASSAB 709

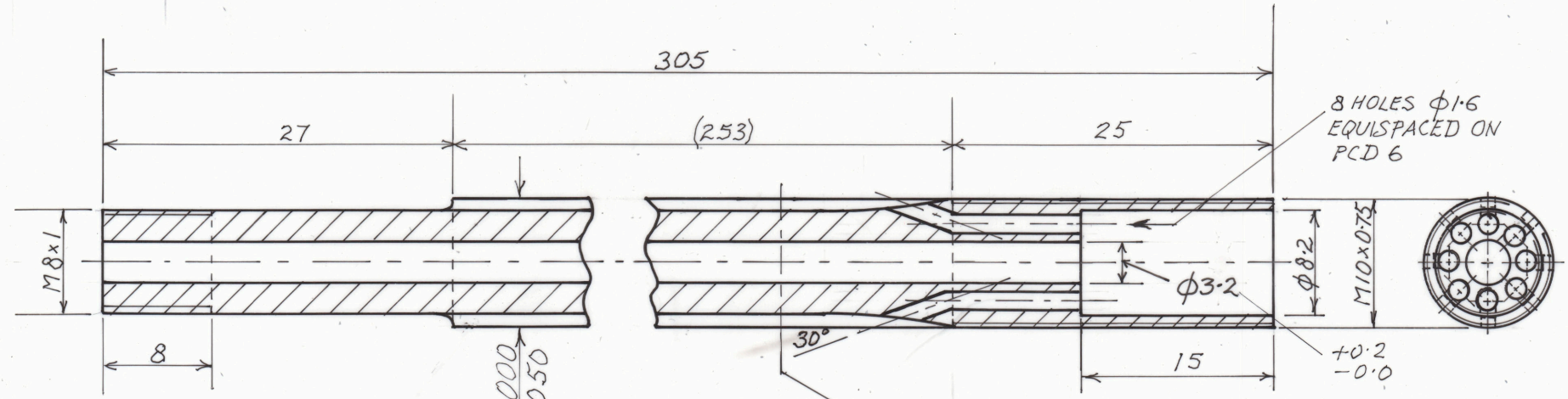
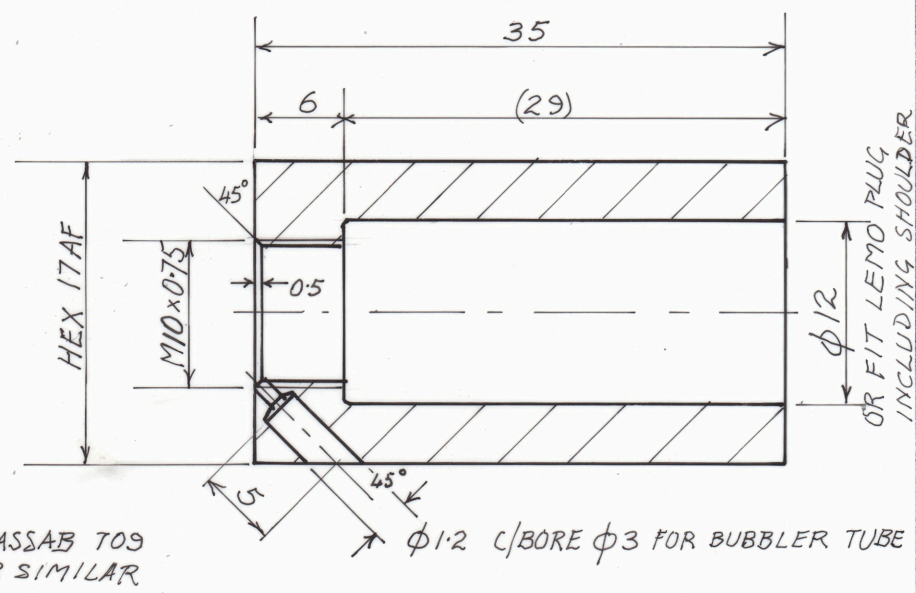
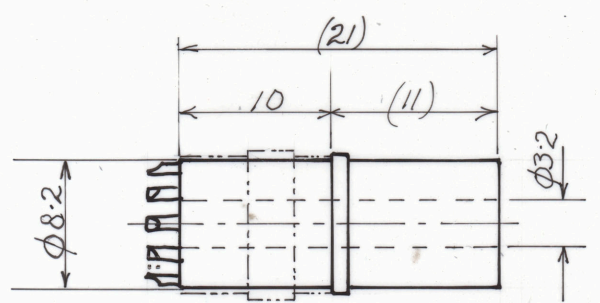

3 ASSAB 709
OR SIMILAR

2 MODIFICATION TO LEMO CONNECTOR
SOCKET INSERT ZNL 2B 308
- TO BE FIXED IN 1 WITH EPOXY
AFTER ATTACHING ELECTRICAL
LEADS SHEATHED IN ϕ OD TEFLON
LEMO PLUG FHG-2B-308

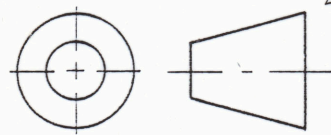

DIMENSIONS IN MILLIMETERS -
DO NOT SCALE

TOLERANCES ± 0.3 UNLESS STATED

PATERSON INSTRUMENTS PTY LTD

HPT TESTING MACHINE
PISTON TIE & LOAD CELL LEADS ASSY
ASSEMBLY & DETAILS

ACN 008 644 273

A3	SCALE 1:1 & 2:1	DATE NOV 1993 JUNE 1995	DRAWING NO 4104 REV REPLACES 4104
----	--------------------	-------------------------------	--------------------------------------