

HALF SECTION B-B

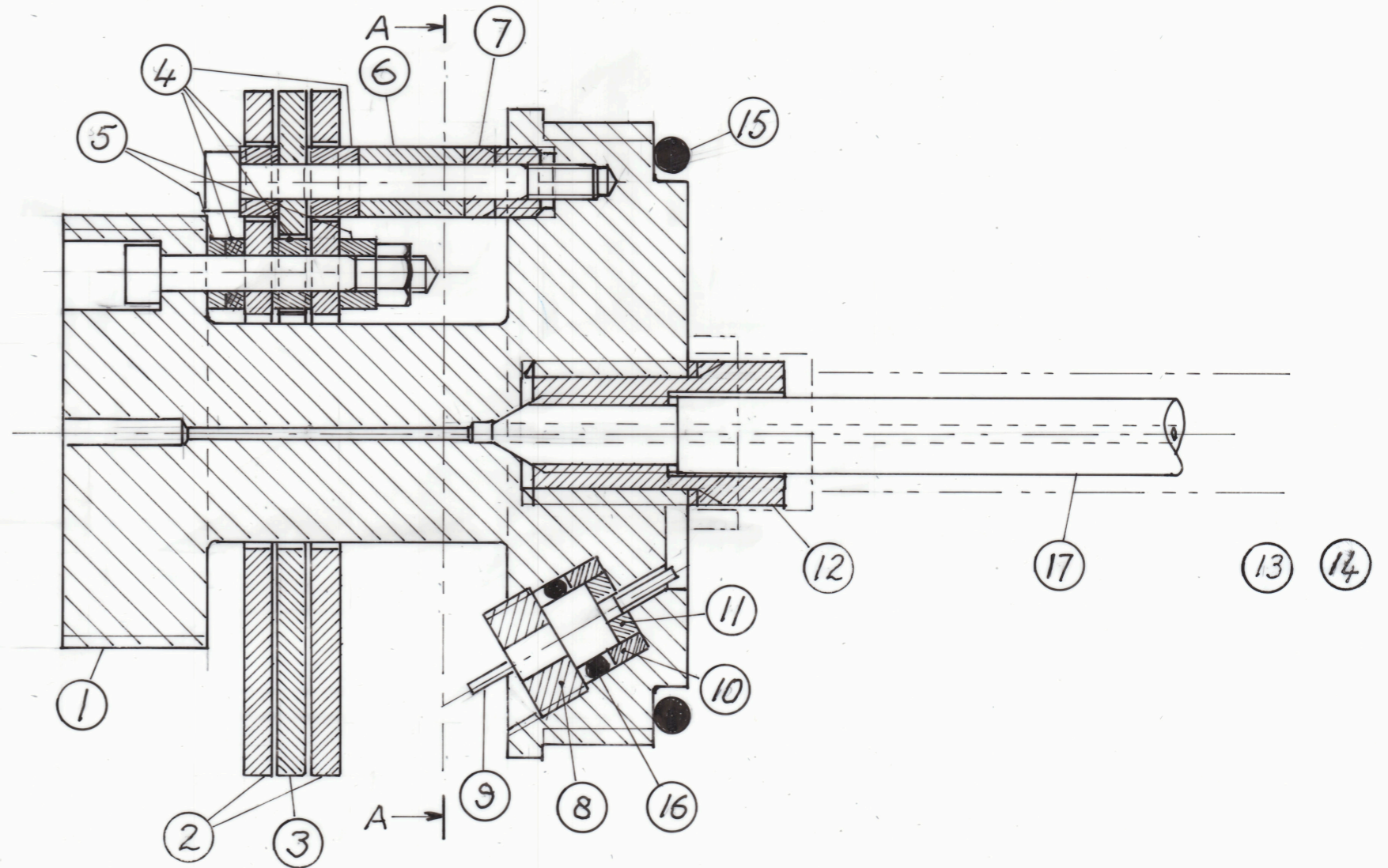

HALF SECTION C-C

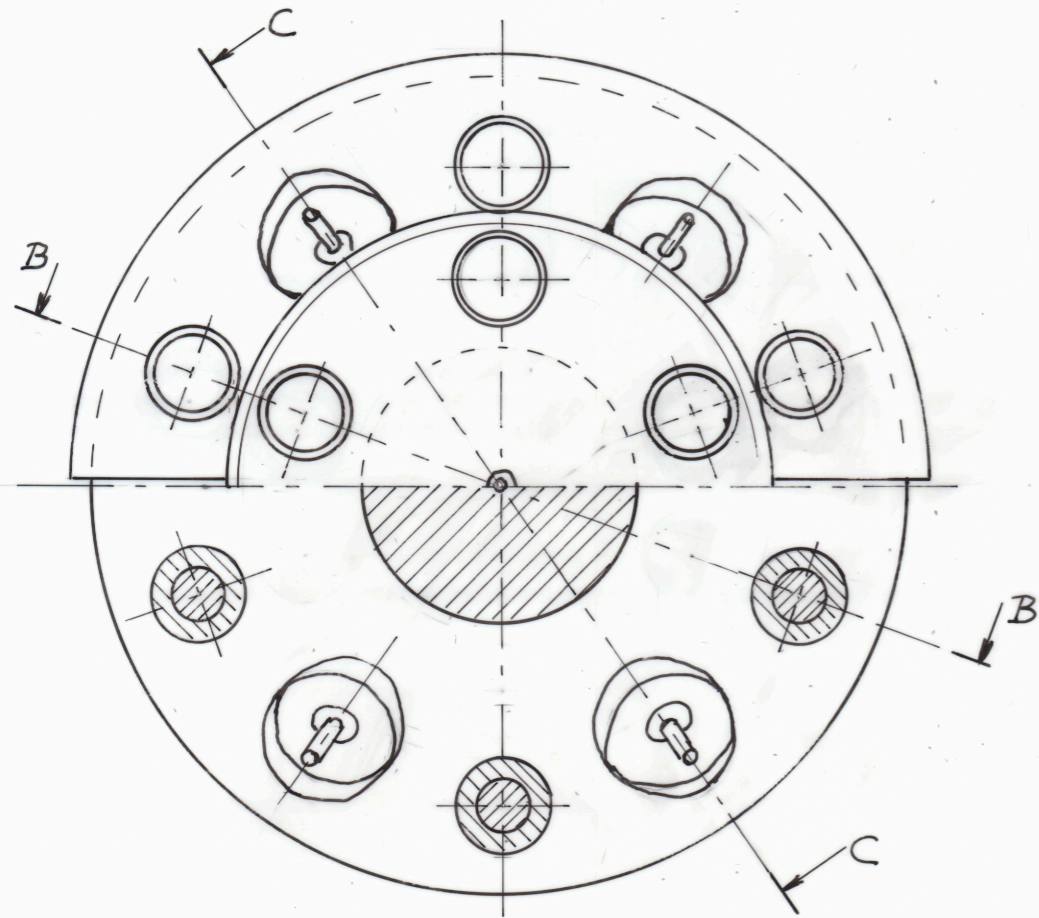

HALF SECTION A-A

NOTE USE RAF RING SPANNER (19)
ONLY FOR TIGHTENING (2)

EXCLUSIVELY LICENCED TO PATERSON INSTRUMENTS PTY LTD

<p>THIRD ANGLE</p>	MATERIAL	DIMENSIONS IN MILLIMETRES DO NOT SCALE	ANU RESEARCH SCHOOL OF EARTH SCIENCES - CANBERRA		
	HEAT TREATMENT	UNLESS OTHERWISE STATED: TOLERANCES ± 0.3 ; $\pm 0^{\circ}30'$ SURFACE FINISH N7 REMOVE BURRS ETC $0.3 \times 45^{\circ}$ MAX	HIGH PRESSURE/TEMPERATURE TESTING MACHINE CAPACITANCE LOAD CELL GENERAL ASSEMBLY		
		DRAWN TO AS 1100	A3	SCALE 2:1	DATE JAN 1988
					DRAWING NO 4200 ^{SUPERCEDED}